



---

# Evaluating Fall Monarch Butterfly Roadkill Hotspot Incidence and Potential Roadkill Mitigation

Technical Report 0-7022-R1

---

Cooperative Research Program

TEXAS A&M TRANSPORTATION INSTITUTE  
COLLEGE STATION, TEXAS

sponsored by the  
Federal Highway Administration and the  
Texas Department of Transportation  
<https://tti.tamu.edu/documents/0-7022-R1.pdf>





## Technical Report Documentation Page

1. Report No. FHWA/TX-22/0-7022-R1	2. Government Accession No.	3. Recipient's Catalog No.	
4. Title and Subtitle Evaluating Fall Monarch Butterfly Roadkill Hotspot Incidence and Potential Roadkill Mitigation		5. Report Date March 2022	
		6. Performing Organization Code	
7. Author(s) Tracy, J., Birt, A, McFalls, J., Prozzi, J. Coulson, R.		8. Performing Organization Report No. Report 0-7022-R1	
9. Performing Organization Name and Address Texas A&M AgriLife Research/Texas A&M Transportation Institute The Texas A&M University System College Station, Texas 77843		10. Work Unit No. (TRAIS)	
		11. Contract or Grant No. Project 0-7022	
12. Sponsoring Agency Name and Address Texas Department of Transportation Research and Technology Implementation Office P.O. Box 5080 Austin, TX 78763-5080		13. Type of Report and Period Covered Technical Report: August 2019–August 2021	
		14. Sponsoring Agency Code	
15. Supplementary Notes Project performed in cooperation with the Texas Department of Transportation and the Federal Highway Administration.			
16. Abstract Roadkill of monarch butterflies and other arthropods and roadside nectar plants were recoded across Texas in 100 m transects in the fall and spring from fall 2019 to spring 2021. Texas fall monarch roadkill data from this and previous studies was used to extrapolate roadkill across the state, identify monarch roadkill hotspots, and develop MaxEnt monarch roadkill niche models. Monarch roadkill in Texas was estimated at 1-3 million per year in 2016, 2018, and 2020, representing about 2.5% of the monarch overwintering population. Fall monarch roadkill in Texas hotspots reached 136 per 100 m. Hotspots were concentrated along washes of IH-10 between Sonora and Sheffield, and along coastal causeways from Point Comfort to Corpus Christi. Potential monarch roadkill mitigation methods were reviewed, and two specific implementation strategies were detailed and compared for cost effectiveness:  <ol style="list-style-type: none"> <li>1) Direct mitigation through two-week seasonal monarch flight diverter Specialized Management Areas (SMAs) placed at five roadkill hotspots outside the 30 ft clear zone from the roadway that induce migrating monarchs to fly above the traffic, as has been successfully implemented for migratory purple crow butterflies in Taiwan</li> <li>2) Indirect compensatory mitigation through roadside pollinator habitat SMAs placed at seven sites outside the 30 ft clear zone from the roadway that include protective barrier fencing, planted milkweeds and non-milkweed monarch-preferred nectar plants, and disturbance management.</li> </ol> <p>A preliminary 30 year life-cycle cost analysis estimated that flight diverter SMAs may cost \$49-\$262 per adult monarch saved. Planted pollinator habitat SMAs with 726 milkweeds per acre density cost \$30-\$53 per adult monarch produced over 30 years. Non-planted pollinator habitat SMAs could have lower costs per produced monarch of \$23-\$41 over 30 years if milkweeds increased 83-100% with protection and disturbance management alone. Pollinator habitat SMAs would also be useful for protecting rare roadside plants.</p>			
17. Key Words Monarch Butterfly, Milkweed, Arthropod Roadkill, Flight Diverter, Interstate Highway 10, Texas State Highway 35, Roadkill Niche Model		18. Distribution Statement No restrictions. This document is available to the public through the National Technical Information Service; Alexandria, Virginia 22312; <a href="http://www.ntis.gov">http://www.ntis.gov</a>	
19. Security Classif. (of this report) Unclassified	20. Security Classif. (of this page) Unclassified	21. No. of Pages 548	22. Price

# Evaluating Fall Monarch Butterfly Roadkill Hotspot Incidence and Potential Roadkill Mitigation

TxDOT Project 0-7022 Project Research Report (R1)

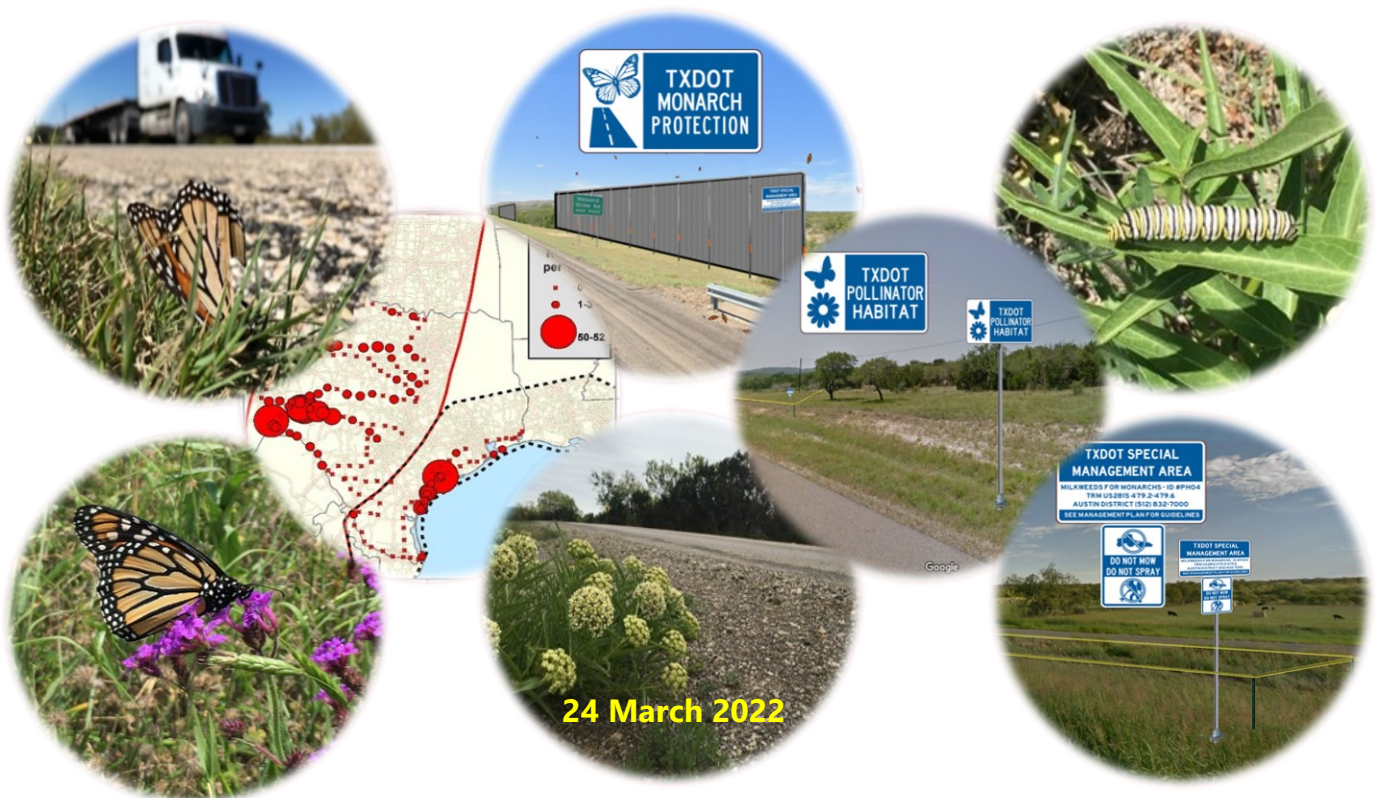
James Tracy, Ph.D., Texas A&M AgriLife Research

Andrew Birt, Ph.D., Texas A&M Transportation Institute

Jett McFalls, B.L.A., Texas A&M Transportation Institute

Jolanda Prozzi, Texas A&M Transportation Institute

Robert Coulson<sup>1</sup>, Ph.D. (Project Supervisor), Texas A&M AgriLife Research



Prepared for

Texas Department of Transportation, Joanne Steele, Research Project Manager,  
TxDOT Research & Technology Implementation Division, Austin, Texas

<sup>1</sup>Address: Knowledge Engineering Laboratory, Department of Entomology, Texas A&M University, 2475  
TAMU, College Station, Texas 77843

Phone: 979-845-9725; Email: Robert.Coulson@ag.tamu.edu



## DISCLAIMER

The contents of this report reflect the views of the authors, who are responsible for the facts and accuracy of the data presented herein. The contents do not necessarily reflect the official view or policies of the Federal Highway Administration (FHWA) or the Texas Department of Transportation (TxDOT). This report does not constitute a standard, specification, or regulation. Mention of trade names or commercial products does not constitute an endorsement or recommendation for use.

This report is not intended for construction, bidding, or permit purposes. The researcher in charge of this project was Robert Coulson.

The United States Government and the State of Texas do not endorse products or manufacturers. Trade or manufacturers' names appear herein solely because they are considered essential to the object of this report.

## ACKNOWLEDGEMENTS

This project was conducted in cooperation with TxDOT and FHWA. The authors thank the TxDOT project team including Joanne Steele (Project Manager), John Maresh (Project Advisory Team Lead), Stirling Robertson, Jane Lundquist, Travis Jez, Becki Perkins, and Holly Brady for their help and guidance throughout the project. Sam Glinsky (TxDOT Maintenance Vegetation Specialist) also provided guidance on ideas for roadside pollinator habitats.

We also thank our excellent field workers who collected roadkill and roadside vegetation data, including Janice Bovankovich, Kaitlin Lopez, Anna Capri Perez, and Jasper Klein. We also appreciate Karen Wright (TAMU Entomology Curator) for assistance identifying native bee roadkill. We thank office staff such as Felicita Anzualda (TAMU Entomology) who assisted in travel reimbursements and Erlinda Olivarez (TTI Contracts) who assisted in proposal submission.

## PREFACE

This report is divided into three Parts. Part I presents (1) an introduction on pollinator roadkill, roadkill mitigation options, and monarch ecology (Part I Chapter 1), (2) reviews the categories of potential roadkill mitigation strategies (Part I Chapters 2-6), and (3) evaluates specific monarch roadkill mitigation strategies for Texas (Part I Chapter 7), including a cost comparison for two detailed potential mitigation strategies that are developed from research in Parts II and III: (a) seasonal monarch flight diverters (Part I Chapter 8), and (b) roadside pollinator habitats (Part I Chapter 9). Part II presents results of 2019-2021 spring and fall Texas roadway observations on arthropod and monarch roadkill, including roadkill hotspot distributions, and occurrence of roadside milkweed and monarch-preferred nectar plants (Part II Chapters 1-5). Part III presents results of (1) fall 2019-2021 Texas monarch roadkill MaxEnt niche models (Part III Chapters 2 and 4), (2) four-year summary Maxent monarch roadkill niche models for fall 2016-2019 (Part III Chapter 3), and (3) kernel density estimate models of spring 2017, 2020, and 2021 monarch roadkill, including kernel density models for roadside milkweeds and monarch larvae (Part III Chapter 5).

## TABLE OF CONTENTS

<b>PART I: MONARCH BUTTERFLY ROADKILL MITIGATION OPTIONS FOR TEXAS</b>	<b>1</b>
.....	
<b>PREFACE TO PART I</b> .....	<b>2</b>
<b>EXECUTIVE SUMMARY</b> .....	<b>3</b>
<b>CHAPTER 1. INTRODUCTION</b> .....	<b>4</b>
<b>1.1. Pollinator Declines and Roadkill</b> .....	<b>4</b>
<b>1.2. Roadkill Mitigation Options</b> .....	<b>5</b>
1.2.1. <i>Direct Mitigation</i> .....	6
<b>1.2.1.1. Connectivity Enhancement</b> .....	7
<b>1.2.1.2. Barrier Enhancement</b> .....	9
1.2.3. <i>Compensatory Mitigation</i> .....	9
<b>1.3. Roadkill Mitigation Planning</b> .....	<b>9</b>
<b>1.4. Monarch Butterfly Migration</b> .....	<b>12</b>
1.4.1. <i>Fall Southern Migration</i> .....	12
1.4.2. <i>Overwintering</i> .....	13
1.4.2. <i>Spring Northern Remigration</i> .....	13
<b>1.5. Monarch Butterfly Roadkill</b> .....	<b>17</b>
1.5.1. <i>Monarch Roadkill and Roadkill Hotspots</i> .....	17
1.5.2. <i>Monarch Population Trends and Roadkill</i> .....	17
<b>1.6. Monarch Butterfly Conservation Challenge</b> .....	<b>21</b>
1.6.1. <i>Causes of Monarch Population Decline</i> .....	21
1.6.2. <i>Potential Listing of Monarch Butterflies</i> .....	22
1.6.3. <i>Monarch Candidate Conservation Agreement Assurance</i> .....	23
1.6.5. <i>Consequences of Monarch Federal Listing</i> .....	25
1.6.5. <i>Summary of Monarch Roadkill Mitigation Problem</i> .....	26
<b>CHAPTER 2. CONNECTIVITY ENHANCEMENT: OVERPASS WILDLIFE CROSSINGS</b> .....	<b>28</b>
<b>2.1. Flight Diverters</b> .....	<b>28</b>
<b>2.2. Canopy Crossings</b> .....	<b>29</b>

**2.3 Wildlife Overpasses.....30**

**2.4. Landscape Bridges .....33**

**2.5. Multi-Use Overpasses .....33**

**2.6. Roadway Tunnels .....34**

**CHAPTER 3. CONNECTIVITY ENHANCEMENT: UNDERPASS WILDLIFE CROSSINGS .....35**

**3.1. Viaducts.....35**

**3.2. Large Animal Underpasses.....36**

**3.3. Multi-Use Underpasses .....38**

**3.4. Small/Medium Animal Underpasses.....38**

**3.5. Modified Culverts .....39**

**3.6. Amphibian/Reptile Tunnels .....39**

**CHAPTER 4. CONNECTIVITY ENHANCEMENT: TRAFFIC AND ROADWAY ADAPTATIONS.....41**

**4.1. Traffic Adaptations.....41**

    4.1.1. *Warning Signs* .....41

    4.1.2. *Speed Reductions* .....44

    4.1.3. *Lane Closures* .....44

    4.1.4. *Traffic Calming* .....45

**4.2. Roadside Habitat Adaptations.....46**

    4.2.1. *Reduced Roadside Attractiveness*.....46

    4.2.2. *Increased Road Visibility*.....46

**4.3. Road Infrastructure Adaptations.....47**

    4.3.1. *Altered Lighting*.....47

    4.3.2. *Reduced Curb Height* .....47

    4.3.3. *Drainage Escapes*.....47

    4.3.4. *Wildlife Jumpouts and Aerial Flyouts* .....47

    4.3.5. *Adjustments in Right of Ways and Medians*.....48

    4.3.6. *Road Cuttings* .....48

**CHAPTER 5. BARRIER ENHANCEMENT .....49**

**5.1. Physical Barriers.....49**

    5.1.1. *Fences*.....49

    5.1.2. *Walls, Berms, and Road Cuttings*.....50



5.1.3. Road Crossing Guards..... 50

**5.2. Artificial Deterrents..... 50**

5.2.1. Auditory ..... 51

5.2.2. Visual ..... 51

5.2.3. Olfactory ..... 52

5.2.4. Tactile ..... 52

**CHAPTER 6. COMPENSATORY MITIGATION..... 53**

**6.1. Habitat Enhancement ..... 53**

6.1.1. Vegetation Management..... 59

6.1.2. Disturbance Management ..... 60

6.1.3. Hydrologic Management ..... 63

**6.2. Habitat Restoration ..... 64**

6.2.1. Vegetation Restoration..... 64

6.2.2. Disturbance Restoration ..... 65

6.2.3. Hydrologic Restoration ..... 65

**CHAPTER 7. POTENTIAL MONARCH ROADKILL MITIGATION STRATEGIES ON TEXAS ROADWAYS ..... 66**

**7.1. Developing an Effective Roadkill Mitigation Strategy ..... 66**

**7.2. Direct Mitigation of Monarch Roadkill in Texas..... 67**

7.2.1. Traffic Adaptations for Mitigating Texas Monarch Roadkill ..... 71

**7.2.1.1. Monarch Crossing Seasonal Warning Signs ..... 73**

**7.2.1.2. Monarch Crossing Seasonal Speed Advisory Signs ..... 74**

7.3.1. Habitat Enhancement for Mitigating Texas Monarch Roadkill..... 80

**7.3.1.2. Non-Roadside Habitat Enhancement Areas..... 83**

7.3.2. Habitat Restoration for Mitigating Texas Monarch Roadkill ..... 84

**7.3.2.1. TxDOT Wildflower Program and Erosion Control Seed Mix  
Modifications ..... 84**

**7.3.2.2. Roadside Planted Pollinator Habitat Areas ..... 89**

**CHAPTER 8. DESIGNS FOR IMPLEMENTATION OF DIRECT MONARCH ROADKILL MITIGATION THROUGH  
SEASONAL MONARCH FLIGHT DIVERTERS SPECIALIZED MANAGEMENT AREAS ON TEXAS ROADWAYS  
..... 92**

**8.1. Introduction..... 92**



8.2. Texas Roadside Direct Mitigation Locations ..... 92

8.3. Overall Design ..... 95

8.4 Design Details, Installation, and Approvals ..... 95

8.5. Cost Estimates ..... 109

8.6. Evaluation Protocols ..... 111

8.7. Conclusions ..... 112

**CHAPTER 9. DESIGNS FOR IMPLEMENTATION OF INDIRECT ROADKILL MITIGATION THROUGH ROADSIDE MILKWEED/NECTAR PLANT SPECIALIZED MANAGEMENT AREAS ON TEXAS ROADWAYS ..... 113**

9.1. Introduction ..... 113

9.2. Texas Roadside Indirect Mitigation Locations ..... 113

9.3. Overall Design ..... 116

9.4. Design Details, Installation, and Approval ..... 123

9.5. Cost Estimates ..... 134

9.6. Evaluation Protocols ..... 135

9.7. Conclusions ..... 137

**APPENDIX A. THEORETICAL EFFECTS OF TRAFFIC VOLUMES ON MONARCH ROAD MORTALITY ..... 139**

**APPENDIX B. MONARCH FLIGHT ALTITUDES, AIR FLOW, AND ROAD MORTALITY ..... 142**

**APPENDIX C. MODELLING THE EFFICACY OF MONARCH MITIGATION ACTIVITIES FOR IMPROVING NET MONARCH POPULATION RECOVERY ..... 145**

**APPENDIX D. MONARCH CROSSING SEASONAL WARNING SIGNS WITH ADVISORY SPEED REDUCTION ..... 147**

**APPENDIX E. LOCATIONS OF SPECIALIZED MANAGEMENT AREAS FOR DIRECT AND INDIRECT ROADKILL MITIGATION ..... 154**

**APPENDIX F. COST ESTIMATES FOR MATERIALS AND LABOR FOR INSTALLATION OF ROADSIDE MONARCH FLIGHT DIVERTER NETTING AND ROADSIDE POLLINATOR HABITAT ..... 165**

**REFERENCES ..... 200**

**PART II: TEXAS MONARCH AND ARTHROPOD ROADKILL AND ROADSIDE MILKWEED AND OTHER NECTAR PLANTS ..... 223**

**PREFACE TO PART II ..... 224**

**EXECUTIVE SUMMARY ..... 225**

**CHAPTER 1. INTRODUCTION ..... 226**

<b>CHAPTER 2. FALL 2019 MONARCH AND ARTHROPOD ROADKILL .....</b>	<b>234</b>
<b>Summary .....</b>	<b>234</b>
<b>Methods .....</b>	<b>234</b>
<b>Results .....</b>	<b>235</b>
<b>Discussion .....</b>	<b>237</b>
Monarch Roadkill Estimates.....	237
Arthropod Roadkill Taxa Composition.....	238
Migratory Butterfly Roadkill Prevalence .....	239
<b>Conclusion.....</b>	<b>241</b>
<b>Tables .....</b>	<b>243</b>
<b>Figures .....</b>	<b>248</b>
<b>References.....</b>	<b>259</b>
<b>Appendix .....</b>	<b>266</b>
<b>CHAPTER 3. SPRING 2020 MONARCH AND ARTHROPOD ROADKILL AND ROADSIDE MILKWEEDS AND NECTAR PLANTS .....</b>	<b>272</b>
<b>Summary .....</b>	<b>272</b>
<b>Methods .....</b>	<b>272</b>
<b>Results and Discussion.....</b>	<b>274</b>
Arthropod Roadkill.....	274
Roadside Milkweeds.....	276
Roadside Monarch Preferred Nectar Plants .....	277
Roadside Monarchs.....	278
Conclusion.....	278
<b>Tables .....</b>	<b>279</b>
<b>Figures .....</b>	<b>286</b>
<b>References.....</b>	<b>304</b>
<b>Appendix .....</b>	<b>306</b>
<b>CHAPTER 4. FALL 2020 MONARCH AND ARTHROPOD ROADKILL AND ROADSIDE MILKWEEDS AND NECTAR PLANTS .....</b>	<b>308</b>
<b>Summary .....</b>	<b>308</b>
<b>Methods .....</b>	<b>309</b>
<b>Results and Discussion.....</b>	<b>310</b>
Arthropod Roadkill.....	310

Roadside Milkweeds..... 312

Roadside Monarch Preferred Nectar Plants ..... 313

Roadside Monarchs..... 313

Conclusion..... 314

**Tables ..... 315**

**Figures ..... 329**

**References..... 351**

**Appendix ..... 353**

**CHAPTER 5. SPRING 2021 MONARCH AND ARTHROPOD ROADKILL AND ROADSIDE MILKWEEDS AND NECTAR PLANTS ..... 357**

**Summary ..... 357**

**Methods ..... 358**

    Results and Discussion ..... 358

    Arthropod Roadkill..... 358

    Roadside Milkweeds ..... 360

    Roadside Monarch Preferred Nectar Plants ..... 361

    Roadside Monarchs ..... 362

    Conclusion ..... 363

**Tables ..... 365**

**Figures ..... 366**

**References..... 405**

**PART III: TEXAS MONARCH ROADKILL NICHE MODELS FOR TEXAS ..... 407**

**PREFACE TO PART III ..... 408**

**EXECUTIVE SUMMARY ..... 409**

**CHAPTER 1. INTRODUCTION..... 410**

**REFERENCES..... 410**

**CHAPTER 2. FALL 2019 MONARCH ROADKILL MODELS..... 412**

**SUMMARY ..... 412**

**METHODS ..... 412**

        MONARCH ROADKILL OBSERVATIONS ..... 412

ENVIRONMENTAL VARIABLES ..... 412

MAXENT ROADKILL NICHE MODELS ..... 412

MAXENT ROADKILL EXTRAPOLATIONS ..... 413

FEATURE SELECTION ..... 413

**RESULTS AND DISCUSSION..... 413**

    MAXENT ROADKILL NICHE MODELS ..... 413

    MAXENT ROADKILL EXTRAPOLATIONS ..... 415

**CONCLUSION..... 415**

**TABLES..... 417**

**FIGURES ..... 422**

**REFERENCES ..... 431**

**APPENDIX ..... 433**

**CHAPTER 3. FALL 2016 TO 2019 MONARCH ROADKILL MODELS AND ROADKILL HOTSPOT DISTRIBUTIONS ..... 434**

**SUMMARY ..... 434**

**METHODS ..... 434**

        MONARCH ROADKILL OBSERVATIONS AND EXTRAPOLATIONS ..... 434

        ENVIRONMENTAL VARIABLES ..... 434

        MAXENT ROADKILL NICHE MODELS AND FEATURE SELECTION ..... 434

        MONARCH ROADKILL HOTSPOT DISTRIBUTION AND HOTSPOT INTENSITY ..... 435

        HOTSPOT SEASONAL OCCURRENCE IN TEXAS..... 435

**RESULTS AND DISCUSSION..... 436**

        MAXENT ROADKILL NICHE MODELS AND FEATURE SELECTION ..... 436

        MONARCH ROADKILL HOTSPOT DISTRIBUTION AND HOTSPOT INTENSITY ..... 437

        HOTSPOT SEASONAL OCCURRENCE IN TEXAS..... 438

**CONCLUSION ..... 438**

**TABLES..... 439**

**FIGURES ..... 444**

**REFERENCES ..... 463**

**CHAPTER 4. FALL 2020 MONARCH ROADKILL MODELS..... 466**

**SUMMARY ..... 466**

**METHODS ..... 466**

        MONARCH ROADKILL OBSERVATIONS ..... 466

ENVIRONMENTAL VARIABLES .....	466
MAXENT ROADKILL NICHE MODELS .....	466
MAXENT ROADKILL EXTRAPOLATIONS .....	467
FEATURE SELECTION .....	467
<b>RESULTS AND DISCUSSION.....</b>	<b>468</b>
MAXENT ROADKILL NICHE MODELS .....	468
CENTRAL FUNNEL .....	468
COASTAL FUNNEL.....	469
MAXENT ROADKILL EXTRAPOLATIONS .....	470
CONCLUSION .....	470
<b>TABLES.....</b>	<b>472</b>
<b>FIGURES.....</b>	<b>476</b>
<b>REFERENCES .....</b>	<b>488</b>
<b>APPENDIX .....</b>	<b>490</b>
<b>CHAPTER 5. SPRING TEXAS MONARCH ROADKILL, MILKWEED, AND MONARCH LARVAL KERNEL DENSITY ESTIMATE MODELS .....</b>	<b>496</b>
<b>SUMMARY .....</b>	<b>496</b>
<b>METHODS .....</b>	<b>496</b>
MONARCH ROADKILL, MONARCH LARVAL, AND MILKWEED OBSERVATIONS .....	496
KERNEL DENSITY ESTIMATE SURFACE MODELS.....	497
POTENTIAL ROADSIDE MILKWEED SPECIALIZED MANAGEMENT AREAS.....	497
<b>RESULTS AND DISCUSSION.....</b>	<b>497</b>
MONARCH ROADKILL .....	497
ROADSIDE MONARCH LARVAE.....	497
ROADSIDE MILKWEEDS .....	498
POTENTIAL ROADSIDE MILKWEED SPECIALIZED MANAGEMENT AREAS.....	498
CONCLUSION .....	499
<b>TABLES.....</b>	<b>500</b>
<b>FIGURES.....</b>	<b>502</b>
<b>REFERENCES .....</b>	<b>508</b>
<b>APPENDIX A. MONARCH ROADKILL MODELING GIS LAYER DEVELOPMENT .....</b>	<b>509</b>
<b>Summary.....</b>	<b>509</b>
<b>Introduction .....</b>	<b>509</b>

Roadkill Niche Modeling Methods ..... 509

Environmental Layers in Roadkill Niche Modeling ..... 510

Spatial Resolution of Environmental Layers in Roadkill Modeling..... 512

Previous Environmental Layers for Monarch Roadkill Modeling ..... 514

Selected Environmental Layers..... 515

**Coastal Funnel Land cover, Climatic, and Topographic Latitude Indices..... 519**

Land Cover Indices ..... 519

Climatic and Topographic Latitude Indices ..... 519

**United States Traffic Characteristic Indices ..... 523**

Traffic Volume and Traffic Classification ..... 523

Traffic Speed ..... 523

**Mexico Traffic Characteristic Indices ..... 525**

Developing the Mexico Traffic Characteristic Indices ..... 525

Description of Final Layer ..... 527

**Future Work..... 528**

**References..... 530**

# PART I: MONARCH BUTTERFLY ROADKILL MITIGATION OPTIONS FOR TEXAS

## Seasonal Flight Diverter Monarch Protection Specialized Management Area



## Roadside Pollinator Habitat Specialized Management Area



## PREFACE TO PART I

Part I presents an overview of monarch roadkill mitigation options for Texas and presents specific potential implementation plans and cost comparisons. Chapter 1 introduces pollinator roadkill, roadkill mitigation, and monarch butterflies in Texas. Chapters 2-6 review various categories of roadkill mitigation options, commenting on their applicability to monarch butterflies. Chapter 7 evaluates and ranks different monarch roadkill mitigation options for Texas. Chapters 8 and 9 explore specific potential monarch roadkill implementation plans and costs in Texas, including direct mitigation using flight diverters (Chapter 8) and indirect compensatory mitigation with roadside pollinator habitats (Chapter 9).



## EXECUTIVE SUMMARY

Monarch roadkill significantly contributes to the long-term annual exponential population decline of migrating eastern monarch butterflies. Potential options for mitigation of monarch roadkill in Texas are examined from a multi-species perspective to maximize benefits for a wide variety of fauna impacted by roadkill, as well as for the protection of driver safety and property. Successful examples of direct roadkill mitigation for other butterflies include connectivity enhancement using various wildlife crossing structures, including diversion netting and wildlife overpasses. Compensatory mitigation via monarch habitat enhancement and restoration is examined for Texas considering existing efforts and best management practices for regionally important nectar plant and milkweed species on farmlands, urban areas, and right of ways. The advantages and disadvantages of six direct and seven indirect (compensatory) monarch roadkill mitigation strategies are outlined for Texas roadways. TxDOT has already engaged in three of the seven identified compensatory mitigation strategies, making continued compensatory mitigation more cost effective than direct mitigation. Specific species recommendations were made for continued modification of the TxDOT pollinator seed mixes with additional monarch-preferred milkweeds and nectar species. Habitat enhancement of existing hotspots of roadside milkweeds and monarch nectar plants by establishing monarch habitat roadside marked Special Management Areas (SMAs) is a potentially effective additional compensatory mitigation strategy. Compensatory mitigation focused on enhancing spring season roadside milkweed production as food for first- and second-generation monarch larvae should have the greatest potential for increasing the annual monarch population. Weak correlation of monarch roadkill with milkweed or nectar plant density in Texas lessens the concern for compensatory mitigation to increase roadkill. Detailed plans are developed for indirect monarch roadkill mitigation through the designation of roadside pollinator habitat SMAs where milkweeds and monarch-preferred nectar plants are planted and protected. Detailed plans are also developed for direct mitigation of monarch roadkill through installation of seasonal monarch flight diverters at monarch protection SMAs. Monarch flight diverter SMAs could save individual monarchs at a cost of \$49-\$262 over 30 years. The 30 year cost of producing monarchs in planted pollinator habitat SMAs is about \$30-\$53, which is 89% lower to 8% higher than that of flight diverters. If milkweed production can be increased 83-100% in 726 milkweed per acre non-planted pollinator habitat SMAs through barrier/signage protection and disturbance management, then 30 year costs per produced monarch could be the lowest, at \$23-\$41.

## CHAPTER 1. INTRODUCTION

### 1.1. Pollinator Declines and Roadkill

Long-term steep population declines in a variety of fauna are being recognized. This is exemplified by the recently reported 29% drop in North American bird abundance since 1970 (Rosenberg et al. 2019), and the threatened status of 32% of the world's amphibian species (Bravo and Porzecanski 2018). Various large groups of insects, an important prey based for the aforementioned mentioned taxa, have declined in biomass by over 76% during the last 27 and 36 years in Germany (Hallmann et al. 2017) and Puerto Rico (Lister and Garcia 2018), respectively (Rhodes 2019). The German study focused on flying insects, which includes pollinators such as bees and butterflies (Hallmann et al. 2017). Evidence is mounting that pollinating insects are also in widespread decline (Ollerton 2017, Rhodes 2018). Pollinator declines appear to be mostly associated with highly anthropogenically disturbed regions (c.f., Herrera 2019). The rusty patched bumble bee (*Bombus affinis*) was once common across eastern North America, but the number of populations before 1999 declined by 88%, probably mostly as a result of prairie habitat loss. These bumblebees were listed as federally endangered in 2017 (USDI-FWS 2017a). North American migrating monarch butterflies (*Danaus plexippus*; Lepidoptera: Nymphalidae) serve as an iconic indicator species of insect pollinator health, and there have been steep population declines of 80% from 1993-2013 in the eastern population (Vidal and Rendón-Salinas 2014) and 99% from 1981-2018 in the western population (Pelton et al. 2019). The US Fish and Wildlife Service (USFWS) supported federal listing of the monarch butterfly in December 2020, but listing is currently delayed due to other higher priority listing actions. Texas roadways play a critical role in the successful spring and fall migrations of the eastern monarch butterfly population (USDI-FWS 2020b).

Reasons for the declines in monarchs and other broad taxa are multi-faceted and include climate change, habitat loss due to agricultural intensification and urbanization, and pesticide use (Agrawal and Inamine 2018; Bravo and Porzecanski 2018; Rosenberg et al. 2019; Rhodes 2018, 2019). Reversal of these long-term trends in declining faunal populations will be a huge undertaking, but must begin with locally effective measures for reducing mortality in the various taxa (e.g., Grant et al. 2019). Roadkill is an important anthropogenic mortality factor in birds (Loss et al. 2014, 2015), amphibians (Glista et al. 2008, Schmidt et al. 2008), and insect pollinators, with estimated billions of pollinators killed annually by vehicle collision in North America (Baxter-Gilbert et al. 2015). Migratory butterflies, particularly danaine milkweed butterflies (related to monarchs), appear to be especially susceptible to roadkill in Asia (Her 2008; Taiwan Environmental Protection Administration [EPA] 2010, Santhosh and Basavarajappa 2014). In North America, the first indication that monarch butterfly roadkill could be high was

reported from Illinois, where an estimated 0.5 million monarchs suffered road mortality on interstate highways during one week of the fall migration in September 1999 (McKenna et al. 2001). Badgett and Davis (2015) suggested that monarch roadkill could be higher in the Texas/Mexico funnel as monarchs concentrate in numbers while nearing their Central Mexico overwintering site. High monarch mortality in Texas was recently confirmed by Kantola et al. (2019) and Tracy and Coulson (2019), with potentially higher mortality confirmed in Mexico by Mora Alvarez et al. (2019) (see section 1.3 for additional details on eastern monarch roadkill and population decline).

A multi-species roadkill mitigation strategy can increase cost benefit ratios, especially for more expensive roadkill mitigation options. Accordingly, roadkill mitigation for the monarch butterfly should incorporate benefits to multiple declining species or taxa groups (c.f., Bager and Fontoura 2013), as well as protection of driver safety and property by reducing vehicle collisions with larger fauna. For example, design details of expensive overpass wildlife crossings should include habitats and features facilitating passage of multiple target species, such as barrier fencing and tall vegetation cover for ungulates to protect driver safety and property, drift fencing and low structural and vegetation cover for reptiles and amphibians, and nectar plant habitats for various pollinators. If the wildlife overpass is located within a monarch butterfly hotspot region, then it should include specific seasonally blooming flora attractive to fall migrating monarchs. Consequently, in this review we consider the potential utility of all roadkill mitigation options for promoting not only monarch butterfly population recovery, but benefits to other declining fauna as well as to driver safety and property.

## 1.2. Roadkill Mitigation Options

The two primary roadkill mitigation strategies have been categorized as:

- Direct mitigation – activities that directly reduce the amount of roadkill
- Indirect or compensatory mitigation – activities that generally increase population size and could be useful for offsetting roadkill mortality (luell et al. 2003) (Fig. 1.1).

Below, we present a brief overview of these categories, and in Chapters 2-6, we describe how different mitigation types can be used for monarchs and other pollinators, as well as a variety of other fauna in order to facilitate leveraging the costs of mitigation and enhancing connectivity while supporting driver safety. More detailed roadkill mitigation option design features and specifications for individual target species and species groups can be found in the cited references, particularly luell et al. (2003), U.S. Department of Transportation Federal Highway Administration [USDOT-FHWA] and Central Federal Lands Highway Division [CFLHD] (2011), and van der Ree et al. (2015).

### 1.2.1. Direct Mitigation

Direct roadkill mitigation refers to on-site activities that either enhance connectivity or enhance barriers for wildlife attempting to cross the roadway. A meta-analysis by Rytwinski et al. (2016) revealed that direct mitigation on average reduces roadkill 40% compared to controls. Planning the location of direct roadkill mitigation measures requires careful consideration to maximize the benefits of reduced roadkill to the most target species at the lowest cost. Knowledge of seasonal animal movement patterns and roadkill risk assessments are critical to identify roadkill hotspots for guiding mitigation placement (Iuell et al. 2003, USDOT-FHWA and CFLHD 2011).

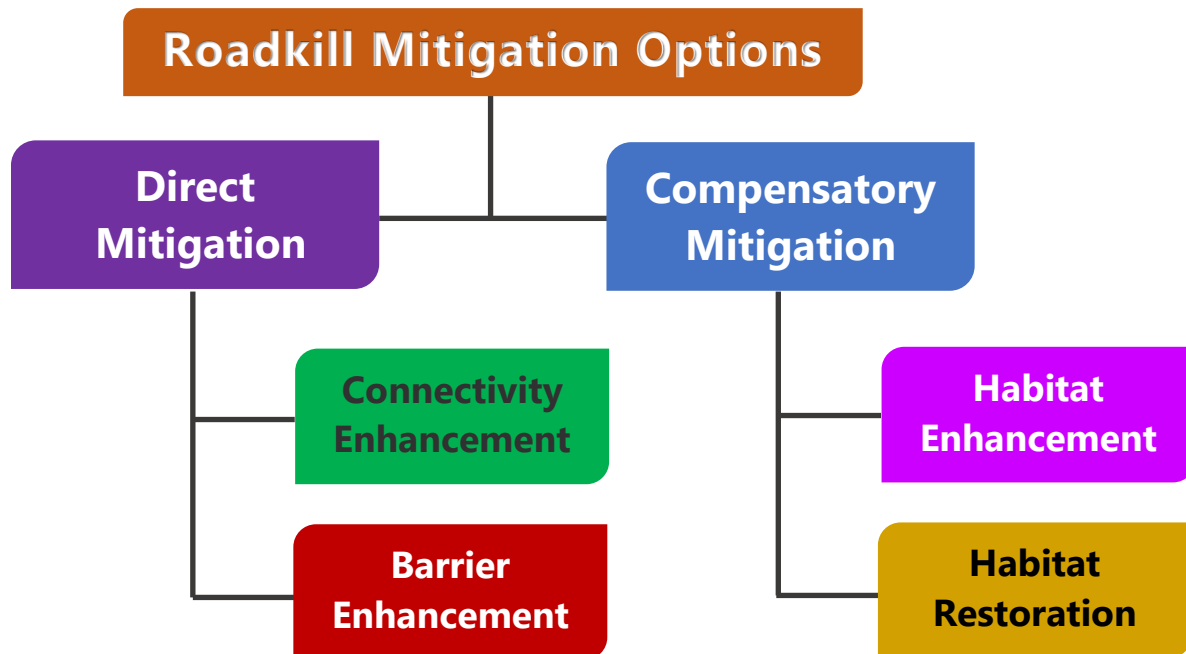


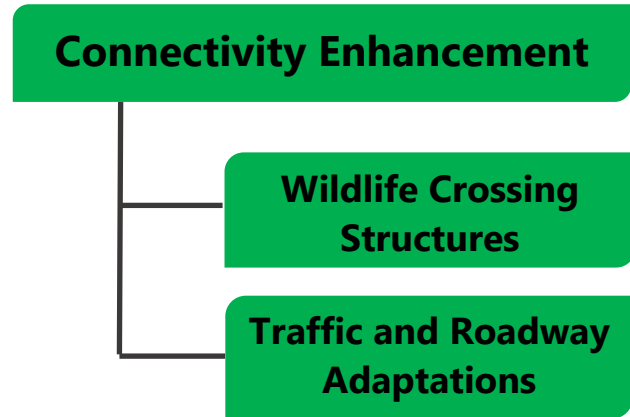
Figure 1.1. Major categories of roadkill mitigation options

### 1.2.1.1. Connectivity Enhancement

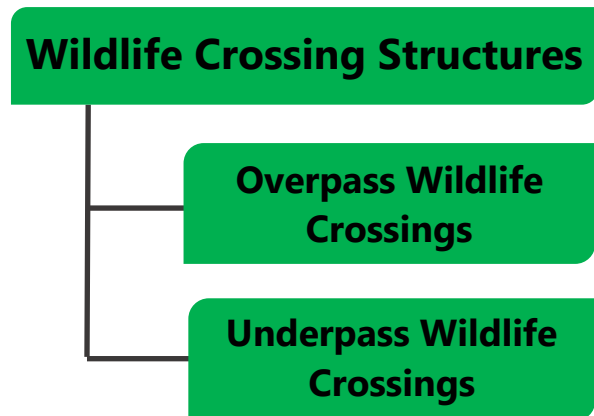
Direct roadkill mitigation that involves improving the chances of wildlife successfully crossing roadways (increased roadway permeability) fall under the category of connectivity enhancement. Connectivity enhancement can include a variety of mitigation activities ranging from wildlife crossing structures to traffic and roadway adaptations (Fig. 1.2). Many of these direct mitigation options are best addressed in pre-road construction design (e.g., Luell et al. 2003). An overview of wildlife crossing structures and traffic and roadway adaptations is provided here.

#### 1.2.1.1.1 Wildlife Crossing Structures

Wildlife crossing structures (USDOT-FHWA and CFLHD 2011), also known as wildlife crossings, wildlife passages (Smith et al. 2015), and faunal passages (Luell et al. 2003), consist of artificial or natural structures facilitating passage of wildlife overhead (overpass wildlife crossings) or underneath (underpass wildlife crossings) roadways (Fig. 1.3). The spacing of artificial wildlife crossing structures for optimal connectivity enhancement and lowered risk of roadkill in animals should consider their home range, dispersal, and migratory behavior. Recommended minimum spacings for crossings range from about every 1 to 15 km for various larger mammals depending on their home range (Luell et al. 2003, Bissonette and Cramer 2008). Crossings will have utility for most invertebrates over only a 200-300 m area (Luell et al. 2003). Monarch butterflies have a perceptual range of up to 400 m (Grant et al. 2018) limiting the distance over which they are potentially attracted to wildlife crossing structures. Bissonette and Cramer (2008) reviewed the deployment of artificial terrestrial and aquatic wildlife crossing structures across the U.S., including many designed for specific taxa. Luell et al. (2003) summarize the utility of a variety of wildlife crossing structures for 26 taxa ranging from moose to tortoises to non-flying invertebrates (their Table 7.1). Rytwinski et al. (2016) found a combination of fencing and artificial wildlife crossing structures reduced roadkill by 83% for large mammals, but artificial wildlife



**Figure 1.2. Connectivity enhancement options for roadkill mitigation**



**Figure 1.3. Wildlife crossing structure options for roadkill mitigation**

crossing structures without fencing were ineffective. Screening or fencing is essential along the edges of the wildlife crossings, and it must be connected to fencing along the roadway in order to guide animal movement towards the crossing (USDOT-FHWA and CFLHD 2011). Wildlife crossing structures are generally both a more effective and more costly means of direct roadkill mitigation than traffic and roadway adaptations described below (Glista et al. 2009, Rtywinski et al. 2016). Preconstruction planning for wildlife crossing structures is probably more economical than retrofitting roadways (Glista et al. 2016), and both pre and post-road construction design options for direct roadkill mitigation are important to consider (e.g. van der Ree et al. 2015). Wildlife crossing structures are examined in detail in Chapters 2-3.

#### 1.2.1.1.2 Traffic and Roadway Adaptations

Traffic and roadway adaptations for roadkill mitigation that facilitate safe movement of wildlife across roadways, including reduced attraction of wildlife to roadways, are also considered under the category of connectivity enhancement (Fig. 1.2). Examples including warning signs, reduced roadside attractiveness, and altered lighting (e.g., Iuell et al. 2003). Traffic and roadway adaptations are further discussed in Chapter 4.

### 1.2.1.2. Barrier Enhancement

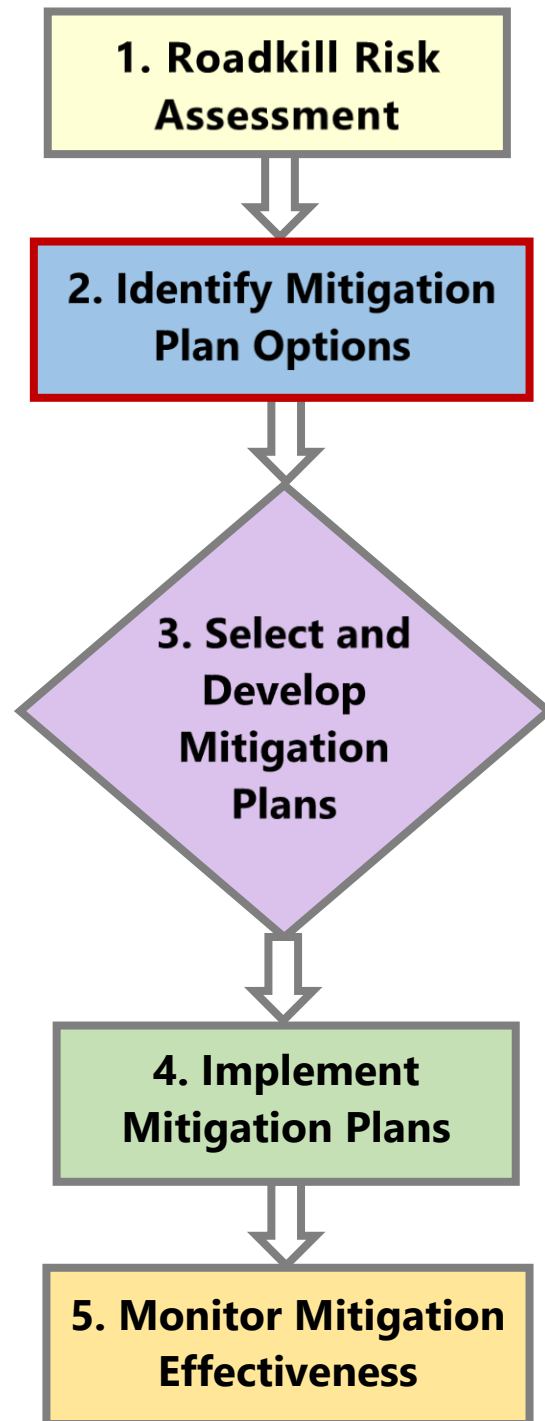
Localized barriers are useful in directly reducing road mortality by reducing access of fauna to the roadway. Barriers should ideally be used in conjunction with connectivity enhancement in order to maintain faunal population connectivity and gene flow, especially for seasonally migratory species and species with large territories (luell et al. 2013). Barrier enhancement can involve physical barriers, such as fencing or walls, and artificial deterrents, such as electric mats. Detailed options for barrier enhancement are covered in Chapter 5.

### 1.2.3. Compensatory Mitigation

Indirect or compensatory mitigation involves offsetting adverse impacts to a wildlife population through enhancement or restoration of wildlife habitat. In contrast to direct mitigation, compensatory mitigation is an indirect form of mitigation that can either be on or off-site from areas of roadkill. The general goal in compensatory roadkill mitigation is to balance negative impacts of roadkill with positive impacts to the wildlife population. Compensatory mitigation can be part of a formal arrangement with USDI-FWS to allow off-site mitigation that offsets adverse impacts to listed species through agreements involving habitat conservation plans (USDI-FWS 2005) and conservation banking (USDI-FWS 2012). Discussion of compensatory mitigation is found in Chapter 6.

## 1.3. Roadkill Mitigation Planning

A detailed protocol for planning roadkill mitigation has been developed by Bissonette and Cramer (2008; see also WildlifeandRoads.org 2007). Our modified overall planning flowchart generally follows their five level one steps (Fig. 1.4). The first step, (1) *Roadkill*



**Figure 1.4. Roadkill mitigation planning flowchart (modified from Bissonette and Cramer 2008)**



*Risk Assessment*, involves identifying the need for roadkill mitigation. At the conclusion of this chapter (section 1.3), we briefly review a roadkill risk assessment for fall migrating monarch butterflies in Texas. The monarch roadkill risk assessment will be covered in more detail in future technical memoranda for Task 2, *Monarch Roadkill Field Observations*, and Task 4, *Spatial Models of Monarch Roadkill Occurrence and Hotspots*.

This review will focus on the second level one step, (2) *Identify Mitigation Plan Options*. The remaining three level one steps in planning roadkill mitigation are beyond the scope of this project, and include steps (3) *Select and Develop Mitigation Plans*, (4) *Implement Mitigation Plans*, and (5) *Monitor Mitigation Effectiveness*. The second level one roadkill mitigation planning step (2) *Identify Mitigation Plan Options* is further broken down into six level two sub-steps (Fig. 1.5), each of which are divided into further level three sub-steps (WildlandsandRoads.org 2007). The bulk of this report will cover level two step (2.1) *Identify Appropriate Mitigation Types*, which is broken down into six level three sub-steps examining how various mitigation options pertain to different species in light of their ecology and landscape features, taking into account engineering and maintenance, and costs versus benefits (Fig. 1.5). The six level three sub-steps for (2.1) *Identify Appropriate Mitigation Types* will be generally addressed for each mitigation category in Chapters 2-6. Chapters 2-6 will review the categories of mitigation options and the different target species to which they apply, including potential applications to butterflies in general and monarchs specifically. Animal vehicle collisions throughout Texas cost motorists \$1.3 billion annually (Wilkins et al. 2019), and it is important to consider potential benefits of monarch butterfly roadkill mitigation options for other species, including large mammals, in light of maximizing benefits versus costs for both road safety and wildlife connectivity in general.



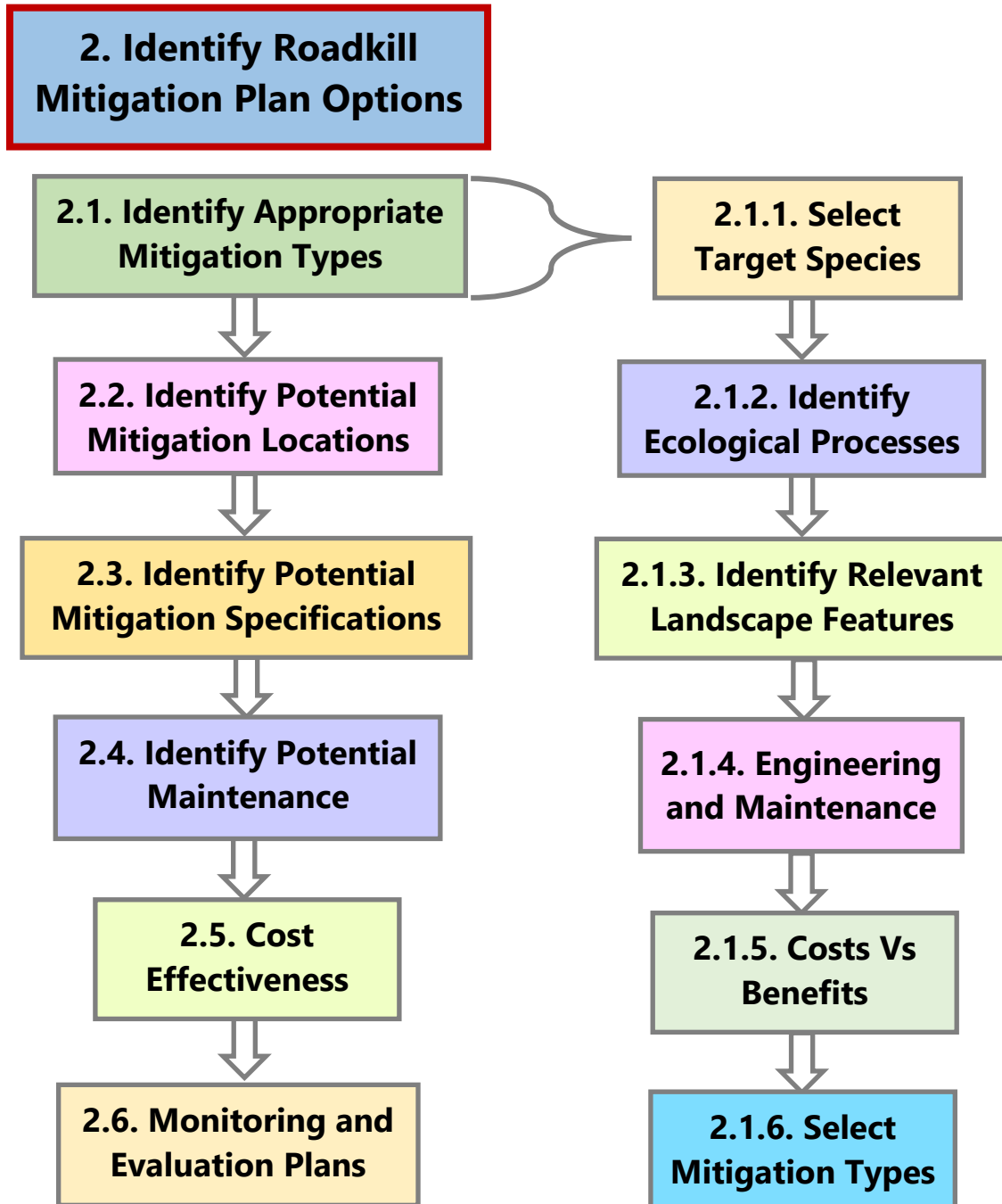
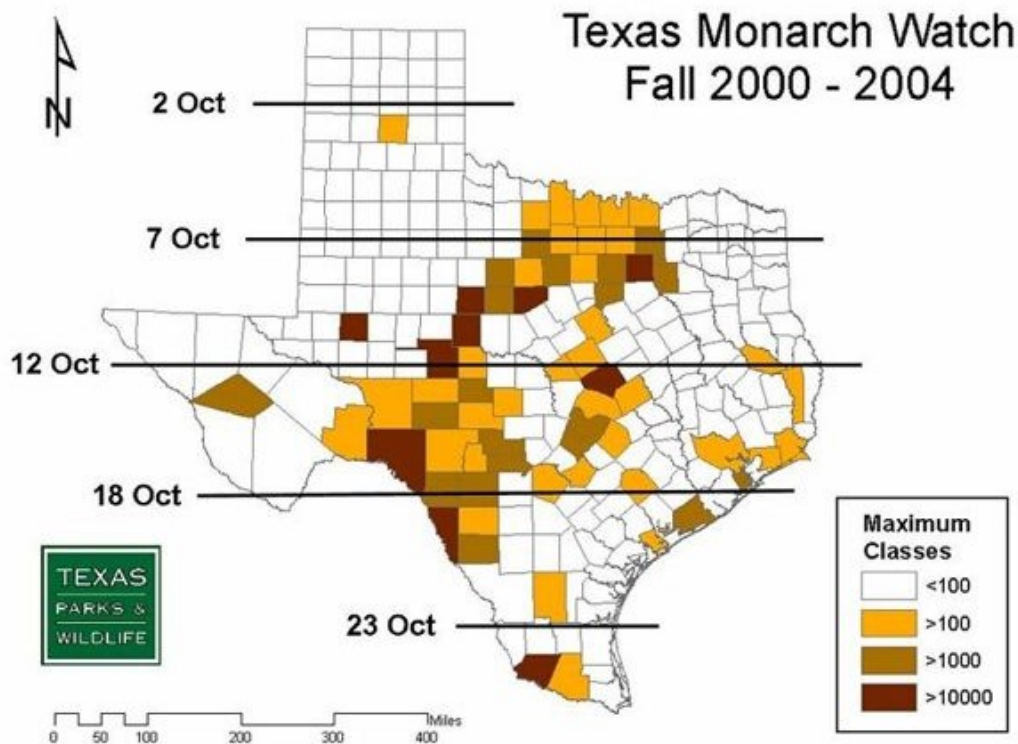


Figure 1.5. Roadkill mitigation planning flowchart level two sub-steps for level one step (2) *Identify Roadkill Mitigation Plan Options* with level three sub-steps for (2.1) *Identify Appropriate Mitigation Types* (modified from WildlifeandRoads.org 2007)

## 1.4. Monarch Butterfly Migration

### 1.4.1. Fall Southern Migration

The southern migration of monarch butterflies occurs as fall commences in the northern US and Canada. The southern migration is thought to be triggered by shortened daylengths and/or decreases in milkweed quality. The migration begins at the northernmost summer range approximately in late August. Adults move southward within the months of September to November. Some adults from the third generation, and most from the fourth, emerge with their reproductive organs in an immature state (reproductive diapause). Reproductive diapause redirects energy and developmental resources from egg production to the southward migration effort (Tatar and Yin 2001). During the southward migration, diapausing adults lay no eggs feed on nectar from a range of flowering plants. Fall migrating adults live for up to 9 months compared to the 2-6 weeks of spring adults. The lifetime of the migrating monarch includes time spent during the southward migration, overwintering and northward migration in the spring. Peak southward migratory populations typically occur the north of Texas at the beginning of October, and south Texas by the third week in October (Fig. 1.6). Adults arrive in their central Mexican overwintering roosts in early to mid-November.



**Figure 1.6. Peak median migration dates of monarchs within Texas (2000 - 2004) (Texas Monarch Watch 2004).**

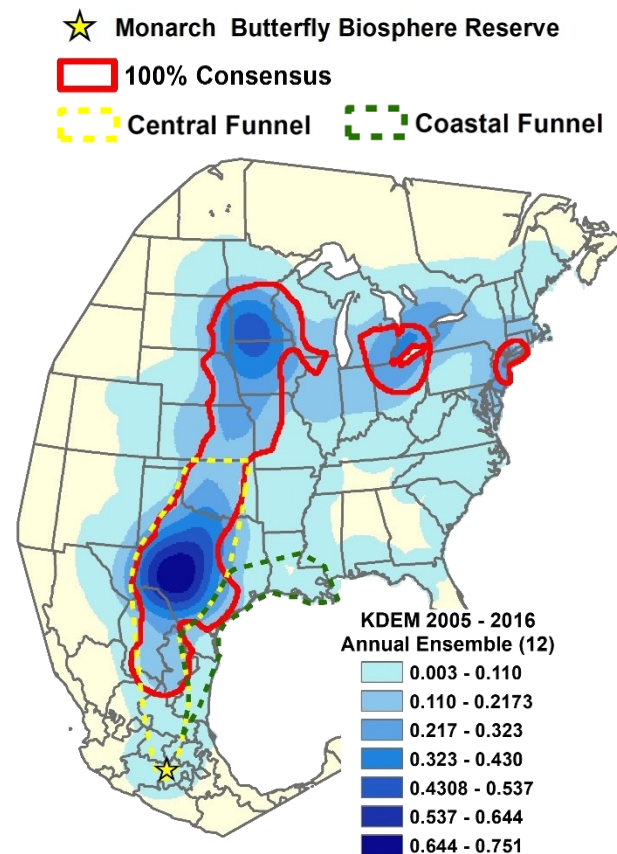
Tracy et al. (2019) modeled the migratory pathways of eastern monarch butterflies from the U.S. and Canada to their overwintering sites in central Mexico (Fig. 1.7). The Central and Coastal funnels identify the largest concentration of monarchs migrating through Texas over the Central and Eastern Flyways, respectively (Figs. 1.7, 1.8). These migratory funnels are where past roadkill observations in Texas have been made and where monarch roadkill hotspots have been found (Kantola et al. 2019, Tracy and Coulson 2019).

#### 1.4.2. Overwintering

Monarch adults overwinter in a state of reproductive diapause. Their overwintering sites occur in elevated Oyamel Fir forests at elevations of 2,400 and 3,600 meters. The forests offer cool, dry conditions that enable them to conserve lipid reserves over the winter. The dry conditions help prevent mortality from occasional temperature drops (butterflies with water on their body surfaces freeze at warmer sub-zero temperatures (-4.2°C) compared to butterflies with no water on their bodies (-7.7°C) (Anderson and Brower 1996). Butterflies roost in large congregations attached to the Oyamel Fir trees. The aggregations protect individual butterflies from freezing and predation. Towards the end of the overwintering period, their reproductive organs become mature, (reproductive diapause ends). In late February to early March the overwintering adults become more active, mate, and then begin their northward spring migration.

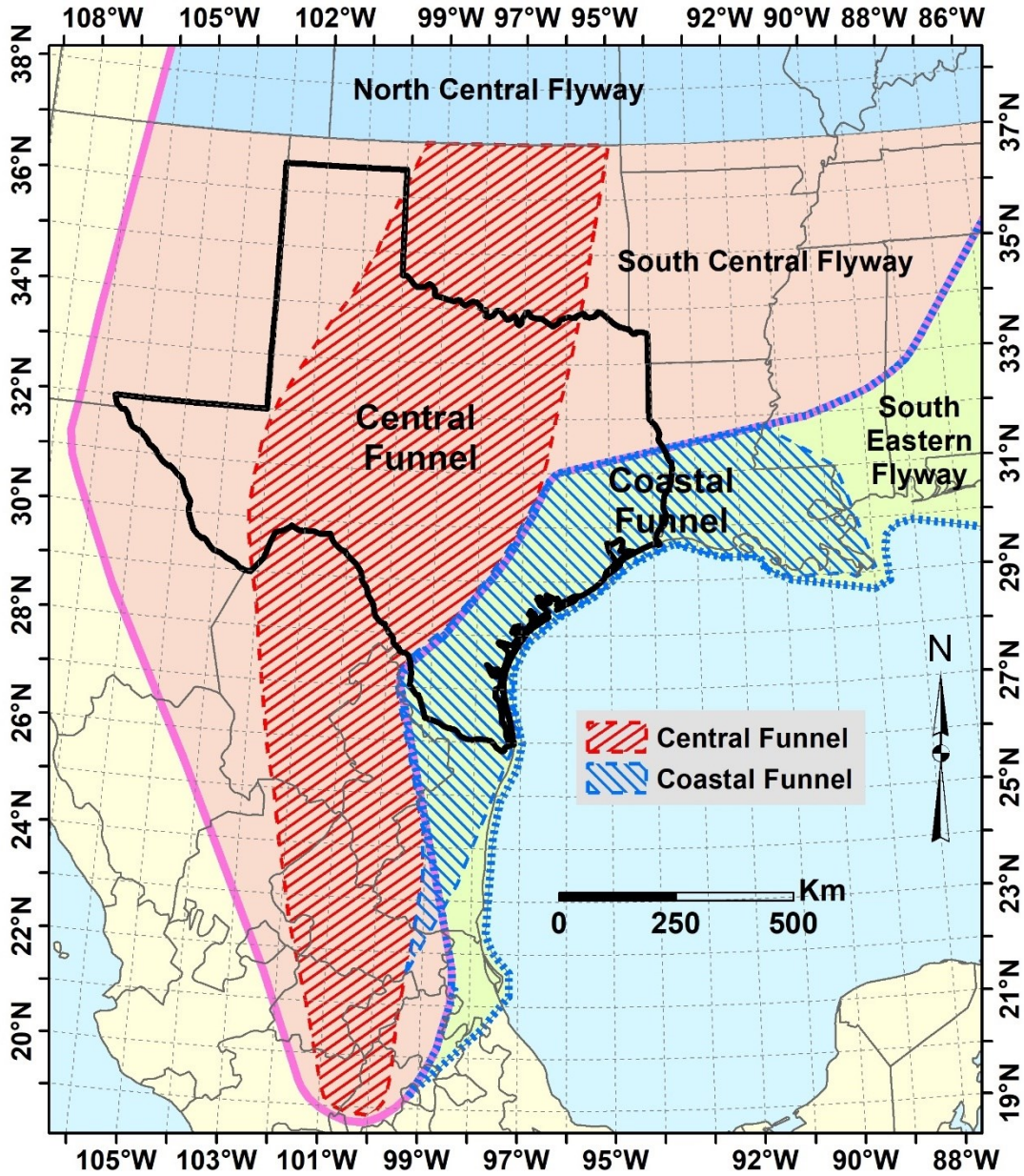
#### 1.4.2. Spring Northern Remigration

The northern remigration occurs when overwintering adults emerge from their winter roosts and begin to move northwards through Mexico and into the southern USA (i.e.,



**Figure 1.7. Monarch fall migration pathway 100% consensus boundary of annual kernel density estimation models from overnight roosts for 2005-2016 with Central and Coastal funnels (Tracy et al. 2019)**



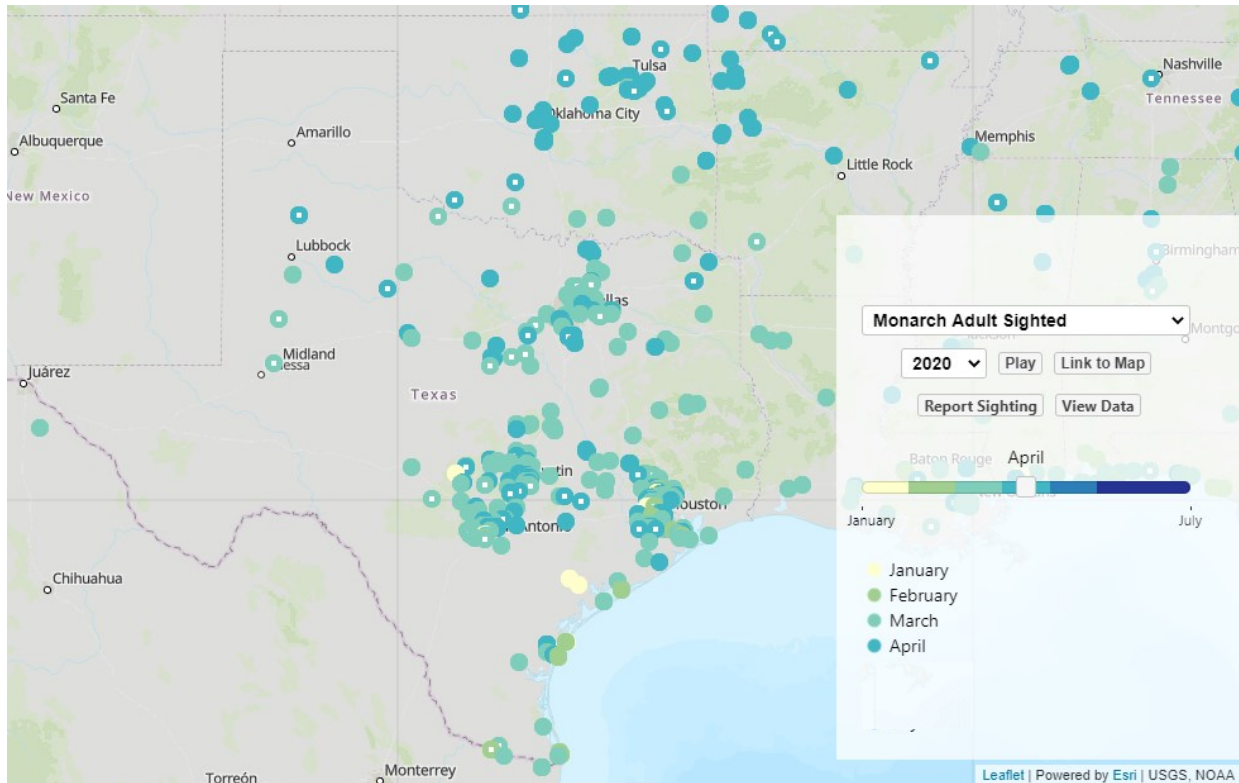


**Figure 1.8. Monarch Central and Coastal funnel southern fall migration pathways (modified from Tracy et al. 2019)**

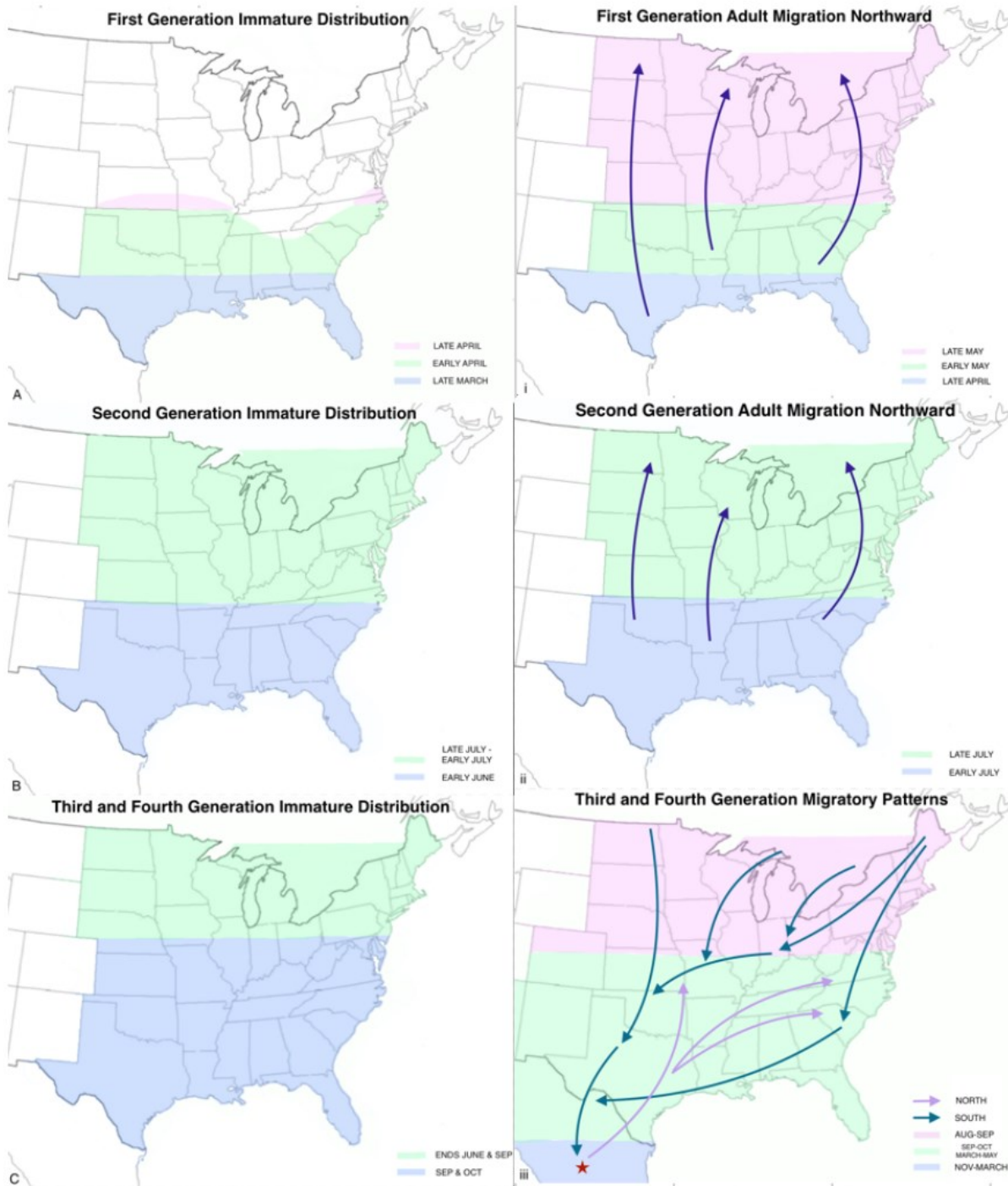
Texas and Florida) over the course of February-April (Fig. 1.9). Overwintered, adult monarchs arrive into southern Texas as early as February. By mid-March adult monarchs are typically sighted at latitudes between Houston, Tx and Dallas, Tx. And by mid-April, overwintering monarchs will typically have moved through and into north Texas and Oklahoma before they die.

As they move northward overwintering adult monarchs deposit eggs on milkweed plants. These eggs develop to the adult form (typically within 30-40 days) to become first generation adults. This generation also moves northward (laying eggs as they do

so) and the process repeats. Adults from the first, second, and third generation live for approximately 2-6 weeks. This movement of monarchs northward occurs through three or four overlapping generations, some researchers suggesting as many as five generations (Flockhart et al. 2013) (Fig. 1.10). Since the population increases exponentially during this time, the process can be considered a population and range expansion in addition to a migration.



**Figure 1.9. Geographic sightings of adult monarchs from January through April, 2020 in Texas. (Journey North 2020).**



**Figure 1.10. Schematic of juvenile and adult monarch ranges throughout the spring migration (redrawn from Monarch Joint Venture 2020).**



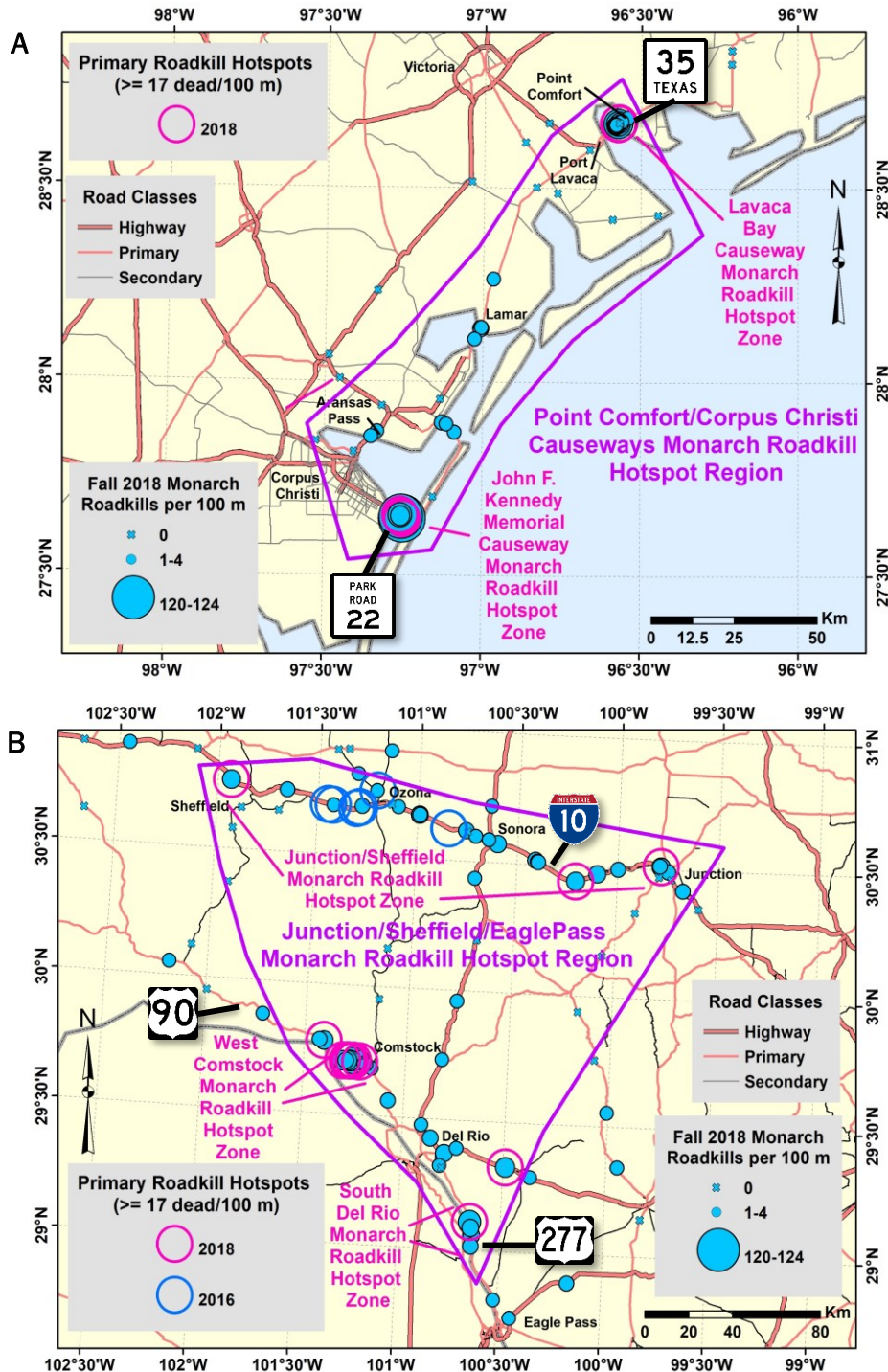
## 1.5. Monarch Butterfly Roadkill

### 1.5.1. Monarch Roadkill and Roadkill Hotspots

Previous fall monarch roadkill surveys in Texas have identified two general roadkill hotspots regions (Fig. 1.11). The Point Comfort /Corpus Christi Causeways Monarch Roadkill Hotspot Region includes causeways from Lavaca Bay to Corpus Christi Bay in the Coastal Funnel (Fig. 1.11A). The Junction/Sheffield/Eagle Pass Monarch Roadkill Hotspot Region extends from Junction to Sheffield to Eagle Pass in the Central Funnel (Fig. 1.11B). These regions encompass primary roadkill hotspots that reach above 17 dead monarchs per 100 m roadside transect (Tracy and Coulson 2019). Analyses of monarch roadkill hotspots in Texas will be covered in more detail in technical memoranda for Task 2, *Monarch Roadkill Field Observations*.

### 1.5.2. Monarch Population Trends and Roadkill

The Texas monarch roadkill data has been used to develop roadkill niche models (Kantola et al. 2019, Tracy and Coulson 2019) for projecting areas of roadkill based on environmental variables and road types. Roadkill niche models are useful in guiding placement for a wide variety of roadkill mitigation methods (Malo et al. 2004), and will be covered in more detail in technical memoranda for Task 4, *Spatial Models of Monarch Roadkill Occurrence and Hotspots*. Estimates of numbers of road killed monarchs in the Central Funnel from 2016-2018 range from about 2-4 million monarchs, representing from 3-4% of the associated estimated monarch overwintering populations (Kantola et al. 2019, Tracy and Coulson 2019). The 2018 mortality in the Texas portion of the Central Funnel represents about 2.6 million butterflies which was 2% of the overwintering population. Values of 2-4% of the overwintering population are significant, considering that the overwintering population has been in an exponential decline at a rate of about 7% per year from 1995 to 2019 (Fig. 1.12).

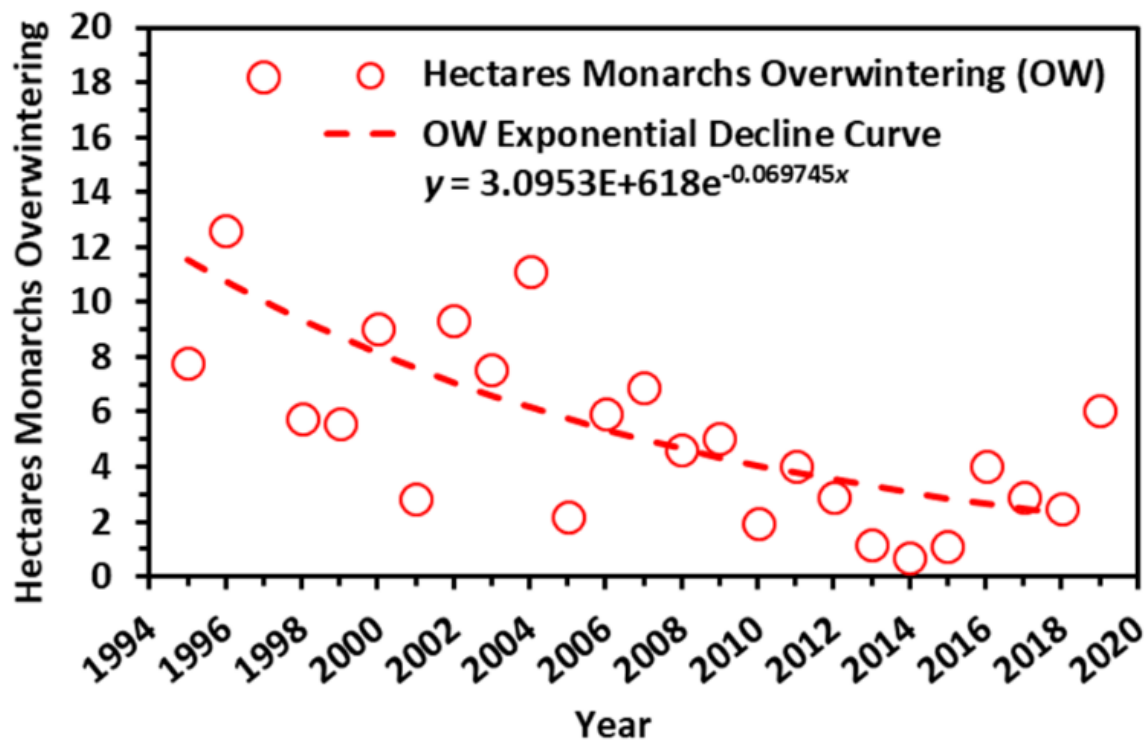


**Figure 1.11. Monarch fall roadkill hotspot zones and hotspot regions in the (A) Central Funnel for 2016 and 2018, and (B) Coastal Funnel for 2018 in Texas (Tracy and Coulson 2019)**

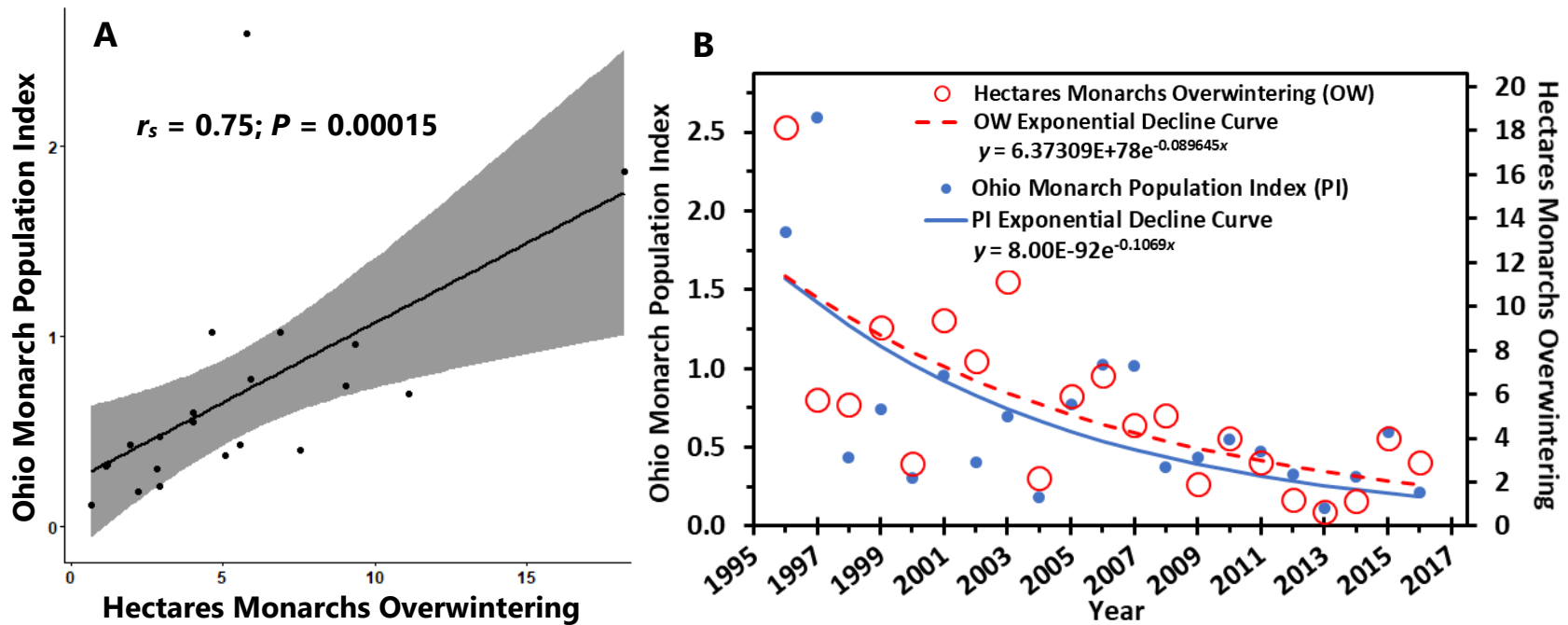
Wepprich et al. (2019) documented the decline of monarchs in Ohio for 1996-2016 using a population index. The Ohio population index is highly and significantly



correlated with the overwintering population decline in Mexico for the same period ( $r_s = 0.75$ ;  $P = 0.00015$ ) (Fig. 1.10A). Both the Ohio and Mexican overwintering populations mirror the significant exponential decline of around 9-10% for 1996-2016 (Fig. 1.10B). The agreement in these data further support that eastern monarch populations are in a concave exponential decline, representing the most alarming category of population trend for a species (Di Fonzo et al. 2013). Reductions in 2-4% of the monarch population lost to roadkill in Texas could significantly contribute to efforts to reduce the continuing 7% long-term decline in eastern monarch numbers.



**Figure 1.12. Annual hectares of monarchs overwintering in Mexico for the 25-year period from 1995 (winter 1994-1995) to 2019 (Vidal and Rendón-Salinas 2014, Monarch Watch 2019). Exponential curve,  $y=ae^{bx}$ , was fitted for the overwintering hectares (adjusted  $R^2=0.45$ ;  $P=0.0002$ ) with an associated declination rate of 6.7% annually for the period.**



**Figure 1.13. A. Spearman’s rank order correlation between Ohio monarch population indices for 1996 to 2016 breeding seasons (Wepprich et al. 2019, Wepprich pers. comm.) and hectares of monarchs overwintering in Mexico for winters starting 1996 to 2016 (Vidal and Rendón-Salinas 2014, Monarch Watch 2019). B. Annual data for Ohio monarch population index and hectares monarchs overwintering in Mexico for the same 11-year period. Exponential curves,  $y=ae^{bx}$ , were fitted using ZunZun.com (2019) for both the population index (adjusted  $R^2=0.38$ ;  $P=0.002$ ), and overwintering hectares (adjusted  $R^2=0.46$ ;  $P=0.0005$ ) values for the period ( $y$  axes are aligned on beginning of exponential curves). Annual population declination rates based on the exponential curves during the period were 10.1% and 8.6% for the Ohio population index and Mexican overwintering hectares, respectively.**

## 1.6. Monarch Butterfly Conservation Challenge

### 1.6.1. Causes of Monarch Population Decline

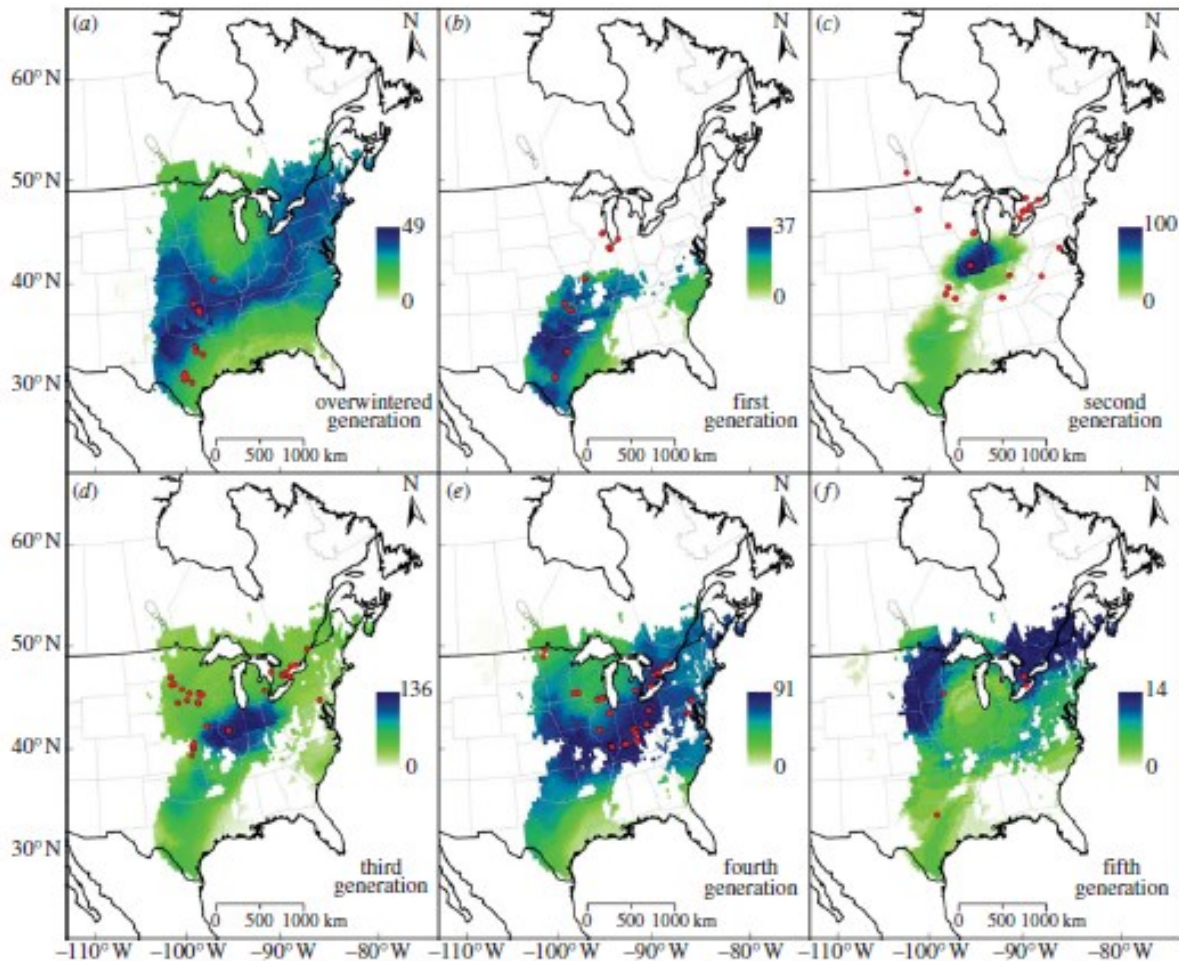
The complex life-history of the monarch butterfly presents considerable conservation challenges. Scientists still debate the most important causes of population decline, and two explanations dominate the literature (Taylor et al. 2020):

- The “milkweed limitation” hypothesis, posits that the decline in the number of milkweed host plants in the major summer breeding area in the Upper Midwest of the U.S. has led to a reduction in the size of the migratory population.
- The “migration mortality” hypothesis, posits that the resources and conditions during the fall migration have declined resulting in an increase in mortality during the migration and a decline in the overwintering population.

In addition to an incomplete understanding of the cause of monarch population decline, the intercontinental geographic range of the species also presents considerable conservation challenges. Activities that affect monarchs (positively or negatively) may be caused by multiple agencies and stakeholders responsible for land management – for example, private landowners, federal and state agencies (including, Departments of Transportation such as TxDOT).

The range and migratory behavior of the monarch also requires that conservation actions must be timed relative to the phenology of monarchs, larval food (Milkweed species) resources, and adult food resources (nectar producing plants). Research is beginning to provide insights into the relative ‘population of value’ of monarchs natal to different geographic regions for each generation of the eastern monarch migratory cycle (Fig. 1.14.). For example, Texas and Oklahoma are identified as the regions giving rise to much of the first generation.

From a management (conservation) perspective, the major factors contributing to the annual demise and increase of monarch populations could feed into a decision matrix that involves the relative cost and benefits (measured as unit increases in monarchs) of restoring fall or spring monarch habitats, or habitats in different areas of the state.



**Figure 1.14. Natal origins of monarchs caught at different stages of the eastern monarch population migratory cycle. In the figures, the blue-to green shading shows the estimated contribution of a natal breeding site (by geography) to adults sampled at different stages in the eastern migratory cycle (blue = high contribution, green = low contribution) (Flockhart et al. 2013).**

### 1.6.2. Potential Listing of Monarch Butterflies

Currently, the monarch population is not listed as Endangered or Threatened by the USFWS. However, in 2014 the USFWS was petitioned to list the species, and, having determined the petition to be substantial, began reviewing the status of the species under the Endangered Species Act (ESA). The original review which was set to be complete in June 2019 was extended to December 2020 because of the complexity of the conservation problem.

Typically, there are three possible outcomes of an ESA review:

- The USFWS may decide that listing is not warranted such that the monarch remains unlisted (it does not become a listed endangered species). Under this scenario, the listing process would end until another successful petition occurs.
- If USFWS determines that listing the monarch is warranted, it will be proposed as an endangered or threatened species. Under this scenario, a proposed listing rule is published in the Federal Register and the listing decision goes to a public review before a final assessment is made.
- The USFWS can decide that the monarch warrants listing, but there are higher priority species that require listing. Under this scenario, the species is added to a candidate list, and its status is reviewed annually by USFWS biologists.

### *1.6.3. Monarch Candidate Conservation Agreement Assurance*

In July 2020 the USFW issued a proposed Nationwide Candidate Conservation Agreement with Assurances and Candidate Conservation Agreement (CCAA/CCA) designed to aid monarch recovery (Monarch CCAA/CCA Development Team 2020). Under the agreement, the USFWS will issue an enhancement of survival permit (EOS) to the University of Illinois at Chicago (UIC). This will enable the UIC to issue certificates of inclusion (CI) to rights-of-way landowners such as TxDOT until such a time that the monarch is listed as endangered or threatened under the ESA. The CCAA provides some useful insurance that efforts to conserve monarchs in Texas will not be offset by management in other states.

After receiving a CI, the ROW landowners (Partners) are required to implement monarch conservation measures on an agreed portion of the land they manage (termed Adopted Acres). This monarch conservation under a CI may include mitigating the incidental take of monarchs (i.e., direct monarch mortality, or indirect mortality caused by damaging food plants or habitat). In return, the monarch CCAA assures partners such as TxDOT that if monarchs are listed in the future, no additional conservation measures will be required (for selected activities on non-Federal lands above those agreed upon in the CCAA).

The monarch CCAA is directed towards non-federal landowners of rights-of-way, including the energy sector and transportation (roads and railroad). The objectives of the CCAA are as follows:

- Enhance and expand available monarch habitat by adopting appropriate conservation measures that promote sustainable breeding (milkweed) and foraging (nectar plants) habitat.

- Maintain a public-private partnership between the USFWS, transportation, and energy sector managers to facilitate voluntary conservation efforts and to communicate its benefits.
- Ensure regulatory certainty and maximize operational flexibility for ongoing rights-of-way and facilities management activities in the event of listing, or by precluding the need to list.

**Table 1.1. Minimum Adopted Acre Targets (in percent landholding or available habitat) for Energy and Transportation Monarch CCAA Partners.**

Sector	Energy			Transportation		
	Transmission	Distribution	Generation	Highways (Interstate, U.S., State)	Highways (County, Local)	Rail
CCAA Adoption Rates (percent)	18	1	9	8	5	5

To enroll in the agreement, Partners must identify a portion of their land on which they will adopt monarch management. Table 1 shows the minimum percentages of specific monarch land management (as a portion of total landholding) required to be registered as management areas for partners to be accepted into the agreement.

CCAA Partners must also plan a number of conservation measures that they propose to implement on the minimum adopted lands, and to develop a list of activity areas that will constitute their Adopted Acres target. The CCAA Biological Opinion Document (USDI-FWS 2020a) identifies a specific example of a transportation related conservation method:

“a right-of-way manager conducting routine mowing and broadcast herbicide treatments would be required to address two key threats – habitat loss from herbicide use and mowing. To comply with the Agreement, the land manager would select conservation measures that address those threats, such as conservation mowing and targeted herbicide use. They would then implement those conservation measures across the Adopted Acres to the extent needed to achieve the Adopted Acres target they are committed to by their CI.”

A full set of example conservation measures is provided in the CCAA (Monarch CCAA/CCA Development Team 2020).

To remain in the CCAA, Partners are required to ensure conservation plans are implemented on their Adopted Acres target (some allowances will be made if targets are not met). Partners are also responsible for reporting compliance and for monitoring and reporting effectiveness. Compliance tracking involves partners reporting the



location of the portion of their land-management unit, its location, and the dates and nature of the applied conservation measure (among other information). Effectiveness monitoring and reporting involves reporting milkweed, floral plants, and monarch presence (among other information) for each activity area.

### *1.6.5. Consequences of Monarch Federal Listing*

An endangered or threatened species listing would have serious consequences for TxDOT and other monarch land managers.

Section 7 of the ESA requires all federal agencies (including state agencies such as TxDOT that receive federal funding) to aid in the conservation of listed species and consult with the USFWS if activities could potentially affect the habitat of individuals of a listed species.

Under Section 7, Federal agencies (and those funded from federal sources) are required to consult with the USFWS if proposed actions may affect a listed endangered or threatened species. Consultation can be informal or formal. The process usually begins as informal consultation which determines the types of listed species that may occur in the proposed action area, and the effect of the proposed action on a species' individuals or habitat. If an adverse effect is likely, the federal agency must submit a formal consultation request, during which information about the proposed project is shared between the USFWS and the agency proposing the action. The result of a formal consultation is a biological opinion document (e.g., USDI-FWS 2019b) that provides the USFWS's opinion on whether the federal agency:

"has insured that its action is not likely to jeopardize the continued existence of a listed species and/or result in the destruction or adverse modification of critical habitat."

Where "Jeopardize the continued existence of" means to engage in an action that reasonably would be expected, directly or indirectly, to reduce appreciably the likelihood of both the survival and recovery of a listed species in the wild by reducing the reproduction, numbers, or distribution. "Destruction or adverse modification" means a direct or indirect alteration that appreciably diminishes the value of critical habitat as a whole for the conservation of a listed species.

Since TxDOT receives federal funding to undertake nearly all projects and activities, it is required to undertake Section 7 consulting. Should the monarch become listed these activities potentially include:

- Regular roadside right of way maintenance (herbicide and mowing activities).

- New road projects, including roadway expansion projects such as widening, intersection or interchange upgrades.
- Research projects that deal with monarchs or other species whose range overlaps that of the monarch.
- Situations where existing road structures are causing significant effects on the survival of monarch individuals (e.g., roadkill hotspots).
- Situations where monarch habitat is threatened by other transportation related issues (e.g., vehicles travelling off road, storage of materials, flooding from roadways and minimally designed culverts, transportation related residues and pollutants).

Participation in the CCAA will undoubtedly help TxDOT over the short- and long- term by encouraging the adoption of semi-regulatory conservation management. Over the long term the CCAA provides assurances (permits in lieu of listing) that will enable maintenance activities to continue seamlessly should the monarch become listed (these assurances extend beyond the registered Action Acres).

However, the CCAA does not explicitly cover TxDOT-USFWS consultation regarding road projects, research, or roadkill. Considering the natural range of monarchs, and the intricacy and variety of activities that TxDOT must undertake to provide safe efficient transportation, uncertainty surrounding the listing of monarchs is understandably high.

Much of this uncertainty can be attributed to the fact that the monarch presents an unprecedented ESA case. While a number of butterfly species are currently federally listed, they generally have highly specific species ranges that extend over only a few states. Additionally, most currently endangered butterfly species are rare, often because they require specific habitat requirements. In contrast, monarch individuals are not rare. Rather, the listing concerns the sustainability of the migratory population, and arguably specific migratory pathways.

Potentially then, a monarch listing could require consultations on a huge area of land managed by TxDOT. Uncertainty of how to mitigate TxDOT activities is also be driven by interpretations of conservation targets and goals (e.g., individual monarchs vs sustainable migratory populations vs sustainable migratory funnels).

#### *1.6.5. Summary of Monarch Roadkill Mitigation Problem*

The monarch exhibits a complex life history that is potentially influenced by multiple land-management agencies and involves multiple stakeholders.

Since 2014 the USFWS has been reviewing the status of the monarch population, with a view to listing it as endangered.

If the monarch was to become federally listed, this would cause considerable management issues for TxDOT several reasons:

- 1) The amount of area potentially occupied by the monarch throughout its continental range, and its range in Texas.
- 2) The ubiquity of milkweed and floral food plants on rights-of-way
- 3) The ubiquity and mobility of adult and juvenile monarchs. Adults disperse long-distances from their natal sites and often cross transportation rights-of-way.
- 4) Uncertainty over regulatory requirements for routine TxDOT management actions such as road projects and maintenance.
- 5) Uncertainty over regulatory requirements for issues such as unusually high roadkill.

While the CCAA relieves some of the regulatory uncertainty surrounding maintenance activities, TxDOT will be required to develop consultative arguments to deal with transportation planning and potentially roadkill hotspots.

As such, TxDOT will benefit from detailed Texas specific information on the population ecology of the species and its interaction with transportation activities.

## CHAPTER 2. CONNECTIVITY ENHANCEMENT: OVERPASS WILDLIFE CROSSINGS

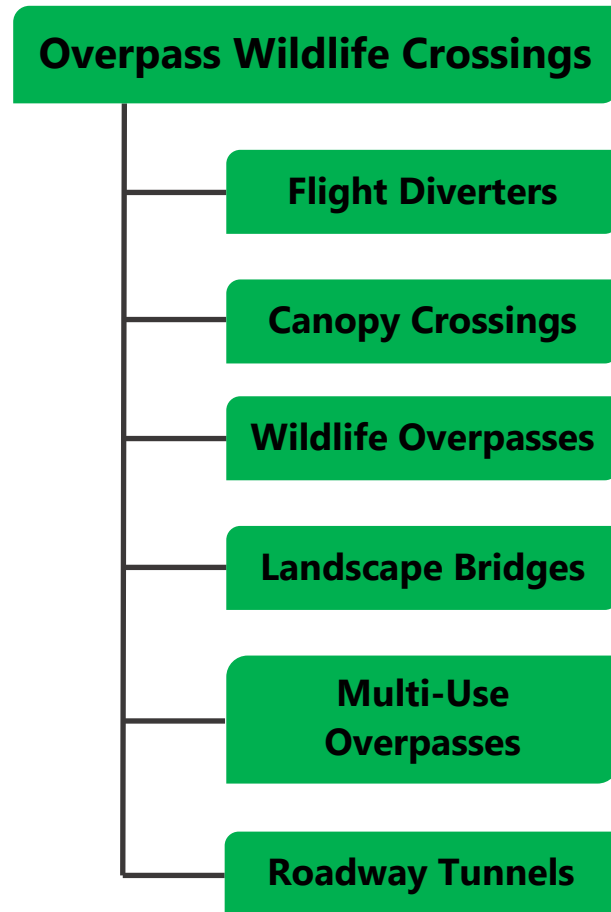
Overpass wildlife crossings represent our general category of artificial and natural structures facilitating connectivity and movement of wildlife over and above roadways and traffic. They can be divided into five categories in order of simple to complex, with only the two simplest categories including natural crossings (Fig. 2.1).

### 2.1. Flight Diverters

Flight diverters (Kociolek et al. 2015), also referred to as altitude guides (Zielin et al. 2016) or screens (luell et al. 2003), are natural or artificial structures intended to direct the flight of aerial fauna above (or below) the traffic when crossing a roadway. Artificial flight diverters include the use of diversion netting, fencing, or diversion poles to guide flight above traffic (Furnes and Soluk 2015, Zielin et al. 2016, Kociolek et al. 2015) (Fig. 2.2).



**Figure 2.2. Colored panel fencing flight diverter for birds along a viaduct in Australia (Kociolek et al. 2015)**



**Figure 2.1. Overpass wildlife crossing options for roadkill mitigation**

Natural flight diverters include tall vegetation screens planted to discourage low altitude flight along the roadway. Recommended dimensions of vegetation screens to guide bird flight include at least a 4.5 m height and width of 10 m for trees and 5 m for shrubs. Vegetation screens can still be effective outside of the immediate right of way area (luell et al. 2003).

Migratory purple crow butterflies (four *Euploea* spp.; Lepidoptera: Nymphalidae: Danainae) in Taiwan had a roadkill rate of

about 3-4% over a section of National Freeway 3, north of Linnei Park in 2006 before mitigation measures (Fig. 2.3) (Taiwan Area National Freeway Bureau [TAFNB] 2015). Seasonal installation of diversion netting at 4-meter height along a roadkill hotspot on the south side of Chingshue Brook Viaduct along National Freeway 3 closest to the migratory source was successful in reducing roadkill (Fig. 2.4). On-site roadkill was reduced by 81-95%, with roadkill rates reduced from 3-4% to 0.19-0.56% between 2007 and 2014 (TAFNB 2015). Installation of about 310 m of 4 m high netting cost around \$78,650 (\$66,000 in 2008) (Her 2008). The diversion netting was extended to cover about 1 km in 2009 (TAFNB 2014). Trees were also planted along an embankment adjacent to the viaduct to form a vegetation screen to guide migrating purple crow butterflies above the traffic (Fig. 2.5).

Experiments with 3 m tall nets did not reduce Oregon silverspot butterfly (*Speyeria zerene hippolyta*) (Lepidoptera: Nymphalidae) flight behavior into a simulated roadway (Zielin et al. 2016). Zilen et al. (2016) also tested novel flight diverters in the form of flower bridges consisting of 1-meter poles topped with either a bright color panel or a pot of flowers and also found them ineffective in altering Oregon silverspot flight behavior away from a simulated roadway.

## 2.2. Canopy Crossings

Artificial canopy crossings (Magnus et al. 2004), also called canopy bridges (Smith et al.



**Figure 2.3. Double-branded purple crow butterflies (*Euploea sylvester swinhoe*) (top 2; Gaga.biodiv.tw 2019) and purple crow butterfly roadkill (TANFB 2007) on National Freeway 3 viaduct, north of Linnei Park, Taiwan**

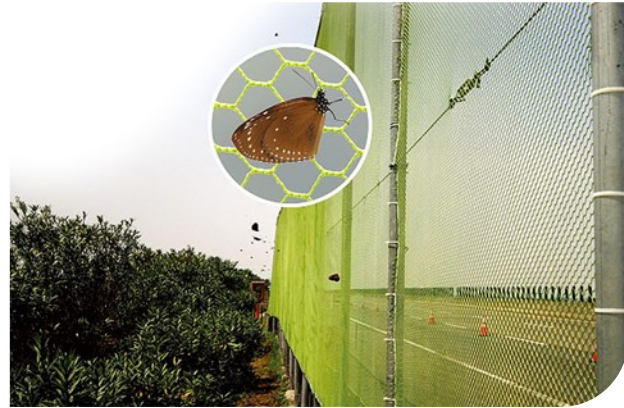


2015) or tree-top overpasses (luell et al. 2009), consist of the extension of a pole, net, taut single rope, or ladder of rope or other material between tree canopies across a road for use by various scansorial mammals and marsupials. Teixeira et al. (2013) found that rope ladder canopy crossings over urban/wildland interface roadways in Brazil were utilized by all the major regional arboreal species, including brown howler monkeys, white-eared opossums, and porcupines (Fig. 2.6). Natural canopy crossings consist of tree branches touching across a road or infrastructure, and they are widely used by arboreal mammals, including primates, in tropical forests (e.g., Donaldson and Cunneyworth 2015, Lindshield 2016,



**Figure 2.5. Trees planted to form vegetation screens for guiding purple crow butterfly migration above highway near National Freeway 3 viaduct near Linnei Park, Taiwan TAFNB 2008)**

(Simpson et al. 2016). High cost limits their use to areas of high to moderate importance for wildlife connectivity (USDOT-FHWA and CFLHD 2011). Wildlife fencing of 2.4 m height is integral in the design of wildlife overpasses for ground dwelling animals, as well as for landscape bridges and multi-use overpasses discussed below. Earthen berms or walls of 2.4 m height can substitute for fencing and also buffer highway noise



**Figure 2.4. Temporary diversion netting (4 m high) for guiding migrating purple crow butterflies over traffic in 400 m section of Chingshue Brook Viaduct on National Freeway 3 north of Linnei Park, Taiwan (TAFNB)**

Gregory et al. 2017). Scansorial arthropods might also benefit from natural canopy crossings.

### 2.3 Wildlife Overpasses

Wildlife overpasses (USDOT-FHWA and CFLHD 2011), also known as green bridges (Georgii et al. 2011), wildlife bridges, or ecoducts (Natural England 2015), are landscaped bridges designed for wildlife use only (Fig. 2.7). They are generally more suitable than underpasses for growth of a variety of vegetation habitat types (luell et al. 2003). Wildlife overpasses are also more utilized than large animal underpasses for some animals, such as ungulates



(Natural England 2015). The minimum recommended width of wildlife overpasses is 40-50 m with a recommended width of 50-70 m (USDOT-FHWA and CFLHD 2011). A soil depth of 1.5-2.4 m depth is recommended to support trees up to 3.6 m height (USDOT-FHWA and CFLHD 2011). The vegetation and habitat on wildlife overpasses can include trees and ponds arranged to provide habitat and cover attracting and facilitating the movement of a wide variety of fauna, including large to small mammals, amphibians, reptile, birds, bats (USDOT-FHWA and CFLHD 2011), non-flying arthropods (Iuell et al. 2003), and flying arthropods, including butterflies (Reck et al. 1997, Gregorii et al. 2011).



**Figure 2.7. Wildlife overpass (ca. 15 m width) on concrete archway with pond in the Netherlands (Stewart 2017)**

woodland bird species will preferentially use wooded wildlife overpasses to open roadways when crossing the highway in the Alsace region of Europe. Similarly, Jones and Bond (2010) found that 75% of bird species in an Australian study, particularly small woodland passerines, only used the wooded wildlife overpass for road crossing, avoiding the open roadway. Jacobson (2005) also recommends vegetated wildlife overpasses for



**Figure 2.6. Artificial rope ladder canopy crossing used by arboreal animals in Brazil (Teixeira et al. 2013)**

USDOT-FHWA and CFLHD 2011), non-flying arthropods (Iuell et al. 2003), and flying arthropods, including butterflies (Reck et al. 1997, Gregorii et al. 2011).

Van Wieren and Worm (2001) documented extensive large and small mammal use of the Terlet Wildlife Overpass in the Netherlands (Fig. 2.8). They also reviewed studies on other European wildlife overpasses, and recommend wildlife overpass widths of over 40 m for large mammals. Keller et al. (1996) found that

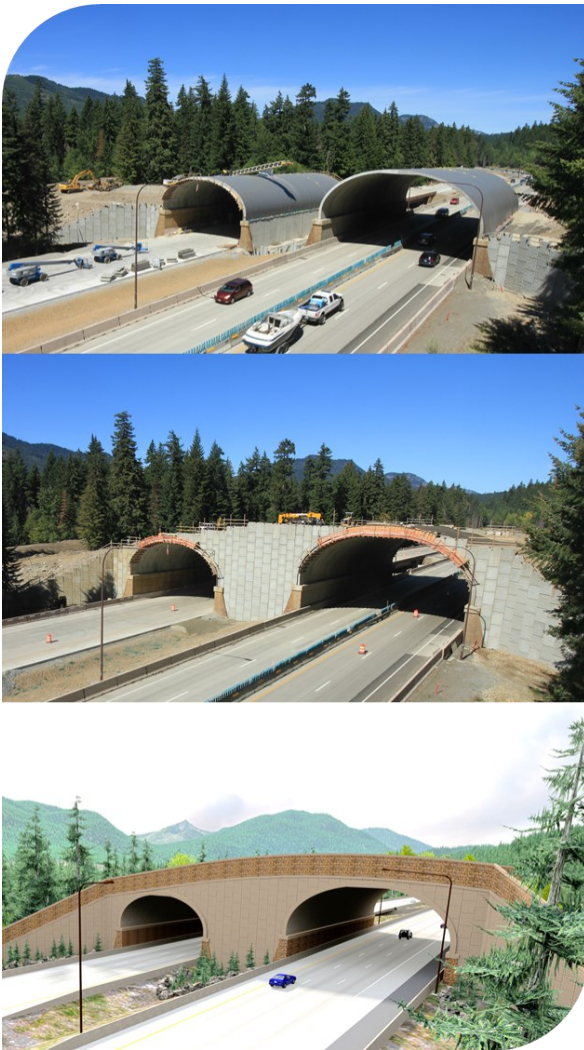


**Figure 2.8. Terlet Wildlife Overpass (50 m width, 95 m length) concrete bridge span along highway A50 north of Terlet, Netherlands (Google Maps 2019)**

ground-dwelling birds. Reck et al. (1997) conducted two hours of butterfly observations along highway A36 in France and found 75 butterflies of 20 species crossing a 10 m width of grass and shrub covered Hardt #3 Wildlife Overpass compared to 13 individuals of five species crossing a 50 m section of nearby open highway, three (2%) of which were road killed. These results indicate that wildlife overpasses have the potential to enhance connectivity and reduce roadkill for butterflies. They found relatively low populations of woodland carabid ground beetles on the wildlife overpass, but greater populations of open-habitat species on the overpass. They also found grasshopper populations were generally lower on the right of way and drier meadow wildlife

overpasses than in surrounding wet meadow habitats. They concluded that corridors of particular habitats used by carabids and grasshoppers connecting source habitats to the overpass are critical for their use (Reck et al. 1997, Georgii et al. 2011).

Individual wildlife overpasses should be considered in the context of other wildlife crossing structures (e.g., wildlife underpasses) for increasing broad scale wildlife landscape connectivity (Natural England 2015). Wildlife overpasses can be designed using steel truss or concrete bridge spans (Fig. 2.8) or arches utilizing pre-fabricated cast-in-place concrete or corrugated steel (cut-and-cover tunnels) (Figs. 2.7, 2.9), and they generally require low maintenance (Iuell et al. 2003, USDOT-FHWA and CFLHD 2011). The 47 m wide Keechelus Wildlife Overpass being completed over Interstate Highway (IH) 90 in eastern Washington cost about \$6.2 million (Bush 2018) (Fig. 2.9). The recently completed 97 m long, 15 m wide Parleys Summit Wildlife Overpass on IH 80 west of Salt Lake City Utah (the first for the state) was constructed as an asymmetrical two-span bridge with a median support beam for \$5 million. It has a landscaped rock surface (WSP.com 2019) that was already



**Figure 2.9. Keechelus Wildlife Overpass (47 m width, ca. 90 m length) concrete archway on IH-90 east of Keechelus Lake, Washington: construction progress and perspective drawing (Washington State DOT 2019)**



utilized by a variety of animals within six months of completion, including deer, elk, and moose, along with occasional predators and a yellow-bellied marmot (Pierce 2019).



**Figure 2.10. Landscape bridge (Smith et al. 2015)**

## 2.4. Landscape Bridges

Landscape bridges, sometimes called green bridges, ecoducts (Natural England 2015), or landscape connectors (Forman et al. 1997), are essentially larger scale wildlife overpasses (discussed above) which have a minimum width of 70 m (Fig. 2.10). A minimum width of greater than 100 m is recommended. They should support all elements of the adjacent natural landscape, including trees, shrubs, and ponds for

attracting a wide variety of wildlife (USDOT-FHWA and CFLHD 2011). Landscape bridges from 140-200 m wide are found in Switzerland. These larger landscape bridges can serve to connect not only wildlife populations, but ecological processes across the landscape, such as flows of groundwater, surface water, soil, fire, and seed dispersal (Forman et al. 1997). Their greater cost limits their application to areas of high importance wildlife connectivity (USDOT-FHWA and CFLHD 2011).

## 2.5. Multi-Use Overpasses

Multi-use overpasses are designed to facilitate movement of both wildlife and humans and they are generally narrower than a wildlife overpass. Recommended widths range from 15-25m with an extreme minimum width of 10 m. The recommended soil depth is 0.5-1m, and they are constructed similar to wildlife overpasses (USDOT-FHWA and CFLHD 2011). A 13 m wide multi-use overpass with a combination bicycle bridge and wildlife overpass for small animals, insects, and birds was recently constructed along highway A556 near Mere, United Kingdom at a cost of \$1.4 million (£1.15 million) (Highways England 2018) (Fig. 2.11).



**Figure 2.11. Multi-use overpass on concrete bridge span (13 m width, 65 m length) on highway A556 west of Mere, United Kingdom (Highways England 2018)**

## 2.6. Roadway Tunnels

Tunnels are a higher cost roadkill mitigation option for pre-road construction design that are generally only considered for very high conservation value hilly landscapes (luell et al. 2003) (Fig. 2.12). They can function as extended landscape bridges benefiting a wide variety of fauna.



**Figure 2.12. Bored roadway tunnel in Bavaria, Germany (luell et al. 2003)**

## CHAPTER 3. CONNECTIVITY ENHANCEMENT: UNDERPASS WILDLIFE CROSSINGS

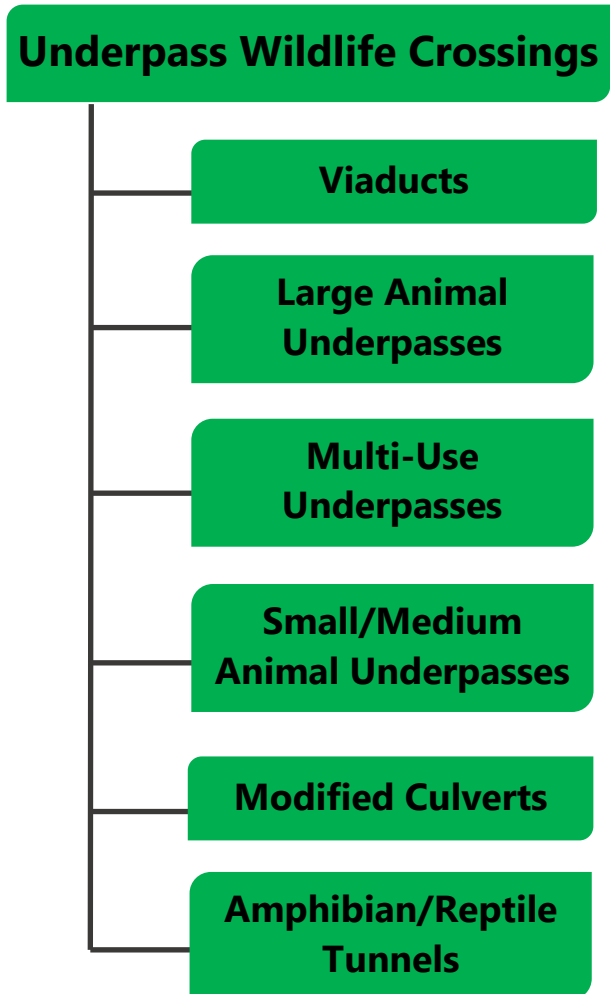
Aquatic and riparian habitats are generally more easily provided in underpass wildlife crossings. In addition, some animals, such as burrowers, may prefer darker, smaller underpass crossings as opposed to more open overpass crossings preferred by ungulates (Luell et al. 2003). There are multiple types of underpass wildlife crossing types that can enhance connectivity for a wide variety of fauna (Fig. 3.1). Most underpasses are best implemented in the road design phase, but some can be modified from existing structures. The smaller structures are more limited in the types of fauna that can utilize them (USDOT-FHWA and CFLHD 2011).

### 3.1. Viaducts

Viaducts, also known as flyovers (USDOT-FHWA and CFLHD 2011) and river crossings (Luell et al. 2003), are often utilized for designing portions of roadways passing over river ways and flood prone riparian areas or wetlands. Viaducts consist



**Figure 3.2. Viaduct over tropical forest in Malaysia (Li 2014)**



**Figure 3.1. Underpass wildlife crossing options for roadkill mitigation**

of multiple concrete bridge or steel beam spans with support structures. Dimensions are highly variable and clearance ranges from low over wetlands to high over canyons (USDOT-FHWA and CFLHD 2011). Minimum clearance under the viaduct should be 5 m for shrubs and other plants to 10 m for trees (Luell et al. 2003). The habitat under the viaduct can be enhanced or created to facilitate movement of a wide

variety of target species, ranging from aquatic to woodlands or dry meadows (USDOT-FHWA and CFLHD 2011). They can also be used in preserving high value connectivity in a variety of other sensitive habitats, such as tropical forest in Malaysia. Habitat enhancement under Malaysian forest viaducts consisted of grass and shrub plantings preferred for animal browse along with salt licks for attracting animals away from roads to cross underneath the viaduct (Li 2014) (Fig. 3.2).

The Chingshue Brook Viaduct on National Freeway 3 north of Linnei Park, Taiwan, traverses a main migratory route of purple crow butterflies (Chapter 2.1). Field observations indicate that butterflies will fly towards the viaduct at an altitude of 3-8 meters and split into two groups when they reach the viaduct, with some flying over and some flying under (TANFB 2014) (Fig. 3.3). In an effort to attract more butterflies to fly under the viaduct, ultraviolet lights were installed under the viaduct in 2007, but they were ineffective (Her 2008).



**Figure 3.3. Path of purple crow butterfly migration over Chingshue Brook Viaduct of National Freeway 3, north of Linnei Park, Taiwan (TAFNB 2014)**

### 3.2. Large Animal Underpasses

Large animal underpasses (luell et al. 2003), sometimes referred to as large mammal underpasses (USDOT-FHWA and CFLHD 2011), have a minimum clearance and width of 4 m and 7 m, respectively, and a recommended clearance and width of >4.5 and >12 m (USDOT-FHWA and CFLHD 2011), respectively, in the US. In Europe, the minimum recommended width is 15 m, with an openness index ( $(\text{width} \times \text{height})/\text{length}$ ) of >1.5 (luell et al. 2003). Large animal underpasses are particularly useful for enhancing connectivity using aquatic habitats, including flowing water and the associated riparian zone. Fencing is also important for guiding animals to wildlife underpasses. Open twin-span large animal underpasses can provide additional lighting preferred by some larger species. Large animal underpasses can also be adapted for use by a variety of smaller fauna depending on the cover and habitat provided, including flying insects (USDOT-FHWA and CFLHD 2011).

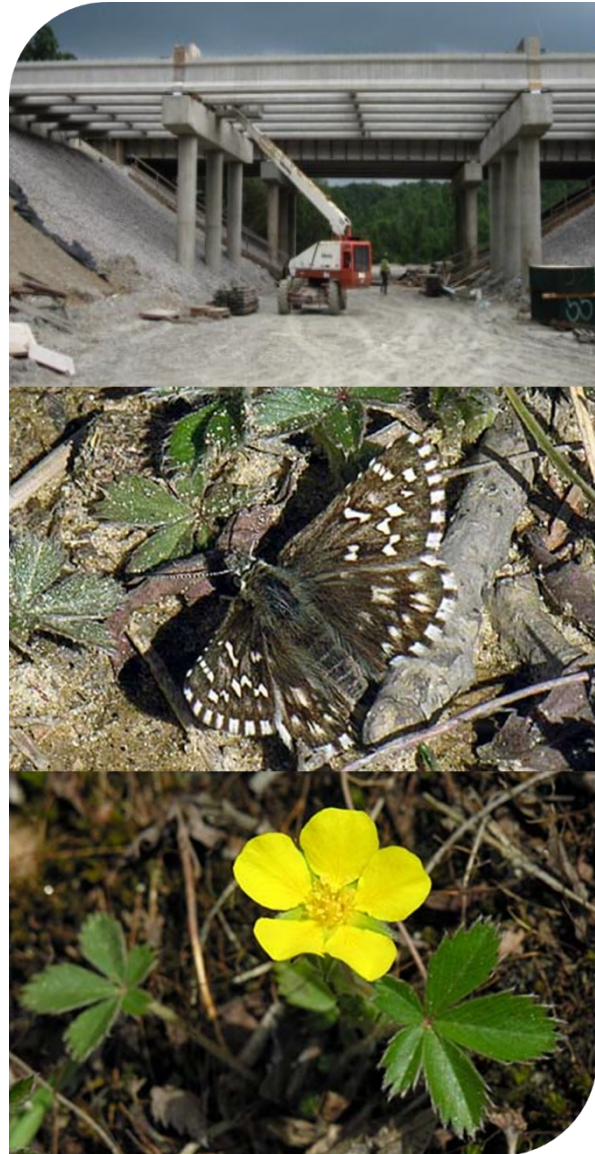


Ohio DOT, in consultation with Wayne National Forest, included a large animal underpass in the design of the U.S. highway 33 Nelsonville Bypass (Fig. 3.4) in order to maintain connectivity of nearby breeding habitat of the state endangered Appalachian grizzled skipper, *Pyrgus wyandot* (Lepidoptera: Hesperiiidae) (Kincaid 2013; NatureServe.org 2019; Lynda Andrews, Wildlife Biologist, Wayne National Forest, personal communication). The area under open twin-span large animal underpass was planted with larval host plant dwarf cinquefoil (*Potentilla canadensis*) and four other preferred nectar plants to encourage breeding and use of the underpass. The skippers are weak flyers, generally not flying higher than 0.6-1 m, which should limit their exposure to traffic 8 m above (Kincaid 2013).



**Figure 3.5. Large animal underpass box culvert (6 x 6 m, w x h) with mule deer trails along Wyoming State Highway 789, 9.7 km north of Baggs, Wyoming (Gearino 2009, Wyoming DOT 2019)**

Large animal underpasses employ a variety of design types including concrete or steel bridge spans, concrete or steel bottomless arches or culverts, or concrete box culverts (USDOT-FHWA and CFLHD 2011) (Fig. 3.5). Construction costs of wildlife underpasses are typically one tenth that of wildlife overpasses (Chung 2014), yielding a price of around a \$0.5 million each.



**Figure 3.4. Large animal underpass construction (ca. 8 m clearance, 9 m width) (Kincaid 2013) for habitat of Appalachian grizzled skipper, including larval host plant dwarf cinquefoil (CarolinaNature.com 2019) on U.S. Highway 33 Nelsonville Bypass, Wayne National Forest, Ohio**

### 3.3. Multi-Use Underpasses

Multi-use (or joint-use) underpasses have size requirements and construction designs similar to large animal underpasses. Ideally, they should be at least 10 m wide in order to include pathways for both human and wildlife usage (Fig. 3.6). Human traffic density



**Figure 3.6. Multi-use underpass box culvert (ca. 1.5 x 1.5 m, w x h) for ocelots along FM 106 at Ted Hunt Road, Texas (USDOT-FHWA and CFLHD 2011)**

should be low and provision of habitat and cover for the target species is important. If properly designed, these crossings can be utilized by the same variety of fauna as large animal underpasses (Iuell et al. 2003, USDOT-FHWA and CFLHD 2011).

Small to medium animal underpasses range from about 0.4 to 2 m diameter (Iuell et al. 2003; USDOT-FHWA and CFLHD 2011), but those including aquatic habitat should be at least 3-4 m in diameter in order to accommodate passage of both aquatic and terrestrial species (underpasses with water flow; USDOT-FHWA and CFLHD 2011). Habitat around and through the underpass should be attractive to a wide variety of species in the area. The largest animals targeted by these structures are predators such as coyotes and foxes. Pipes or other cover should be placed within the underpass to provide cover for smaller mammals and reptiles. Lighting, such as through steel grating on the roadway, is important for use by some larger species. In larger structures with aquatic habitat or subject to flooding, ledges may be required for terrestrial fauna (Fig. 3.7) (USDOT-FHWA and CFLHD 2011). Small/medium animal underpass box culverts may be one of the most economical and effective roadkill mitigation options for many species, with reports of extensive use by multiple species, including turtles, in various studies (Glista et al. 2009). Non-flying arthropods, such as ground-dwelling carabid and tenebrionid

### 3.4. Small/Medium Animal Underpasses

Small to medium animal underpasses range from about 0.4 to 2 m diameter (Iuell et al. 2003; USDOT-FHWA and CFLHD 2011), but those including aquatic



**Figure 3.7. Small/medium animal underpass box culvert (ca. 1.5 x 1.5 m, w x h) for ocelots along FM 106 at Ted Hunt Road, Texas (Kelley 2018)**



beetles, may utilize these smaller underpasses, but only short, well-lit underpasses would probably be used by most larger flying insects. In order to maintain an openness index of 1.5 that may be more attractive to larger flying insects, the length of a 2 m diameter underpass would need to be limited to 3 m, and grating that allows additional daylight would probably be beneficial.

Small to medium animal underpasses are constructed as concrete culverts or bottomless arches. Many small/medium animal underpasses have been constructed for federally endangered ocelots in south Texas, including 12 box culverts in 2017 that were mostly 1.5 x 1.5 m (Kelley 2017, 2018) (Fig. 3.7). Such culverts generally range in cost from \$12,000 to \$500,000 depending on the opening size and length (Jiang et al. 2019).

### 3.5. Modified Culverts

Culverts designed primarily to carry permanent or ephemeral water flows can be modified to accommodate small to large terrestrial animals in addition to aquatic species, depending on their size and flow conditions. Primary modifications to ensure a dry pathway for animals include lowering part of a concrete bottom to provide an elevated dry concrete ledge, or installing elevated shelving at least 0.25 m wide of steel, concrete or wood. An elevated dry ledge of concrete can be designed into prefabricated box culverts (e.g., Fig. 3.7). The most adaptable culverts are concrete bottomless arches or box culverts (Iuell et al. 2003; USDOT-FHWA and CFLHD 2011). Larger culverts of at least 3 m width with greater lighting (e.g., openness index of > 1.5) may be suitable for flying insects if the flooring can be lowered to provide a clearance of at least 2 m above the water (with minimum required length of about 4 m).

### 3.6. Amphibian/Reptile Tunnels

Amphibian/reptile tunnels must be placed in areas of known importance for dispersal and migration, and be associated with drift fences or guiding structures (walls) to funnel movement towards the tunnel. Grated slots over the tunnel can be important in providing lighting and habitat conditions conducive to their use (Fig. 3.8). Helldin and Petrovan (2019) found that amphibian roadkill decreased by 85-100% along



**Figure 3.8. Amphibian/reptile tunnel of multiple prefabricated polymer concrete units (ca. 1 x 0.7 m, w x h) (Legacy Habitat Management Limited 2019)**

segments of road with amphibian/reptile tunnels and drift fencing in Sweden, with a 25-340% increase in successful crossings. They also found that longer fences may be needed for further reductions in amphibian roadkill. Use of amphibian/reptile fencing on lower traffic roads where it may not be needed can do more harm than good for connectivity (Helldin and Petrovan 2019).

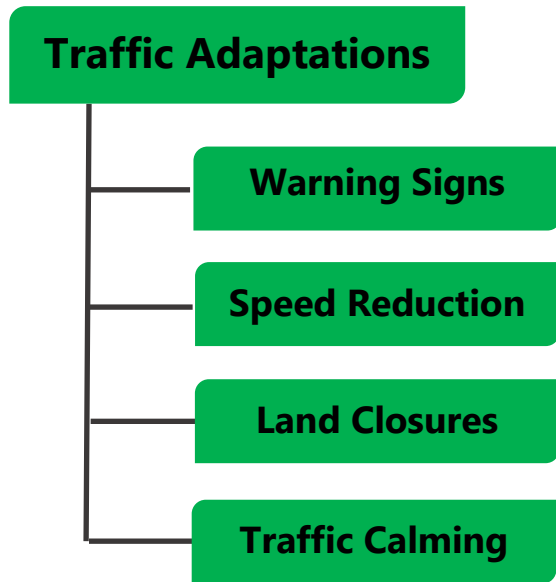
Rectangular concrete walled amphibian/reptile tunnels are desirable to accommodate animal guiding structures and provide more surface area for animal movement. The minimum recommended diameter of the tunnel increases with greater length, ranging from 1 m diameter if less than 20 m length to 2.5 m diameter if from 50-69 m length (luell et al. 2003; USDOT-FHWA and CFLHD 2011). The typical diameters and lengths of these tunnels probably prohibits use for most larger flying insects, but a 2.5 diameter tunnel with 4 m length (openness index of 1.5) might be usable.

## CHAPTER 4. CONNECTIVITY ENHANCEMENT: TRAFFIC AND ROADWAY ADAPTATIONS

Traffic and roadway adaptations for connectivity enhancement can be divided into traffic adaptations, roadside habitat adaptations, and roadway infrastructure adaptations (Fig. 4.1).

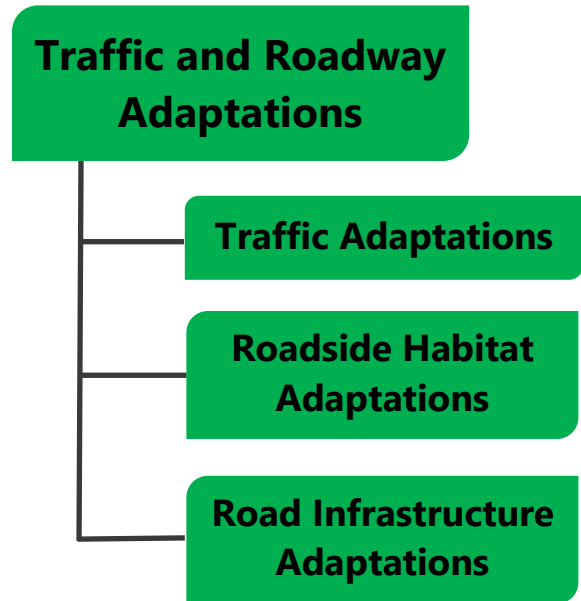
### 4.1. Traffic Adaptations

Road mortality rates can be impacted by both traffic volume and traffic speed (e.g., Hobday and Minstrell 2009, Barthelmess 2014). The first two covered traffic adaptations of warning signs and speed reduction are aimed at reducing traffic



**Figure 4.2. Traffic modification options for roadkill mitigation**

found that snake roadkill hotspot signs placed 100 m before a dummy snake decreased roadkill incidence by about 5%, but there was no roadkill reduction at 1 km, affirming the importance of sign proximity to the roadkill hotspot. Wildlife warning signs are generally not as effective as wildlife fencing and crossing structures for reducing roadkill (Huisjer et al. 2015).



**Figure 4.1. Traffic and road adaptation options for roadkill mitigation**

speed. Lane closures and traffic calming (regional traffic flow reduction and control) can reduce traffic volume and sometimes traffic speed as well (Fig. 4.2).

#### 4.1.1. Warning Signs

Wildlife warning signs are designed to increase driver awareness of fauna crossing the road so that they lower their speed and seek to avoid wildlife vehicle collisions. Placement in roadkill hotspot areas for the target taxa is critical for their effectiveness (Huisjer et al. 2015). Collinson et al. (2019)



Wildlife warning signs are sometimes considered as primarily providing mortality reduction rather than connectivity enhancement (luell et al. 2003). Huisjer et al. (2015) contend that wildlife warning signs are not designed to increase connectivity, but rather increase driver safety and reduce property damage from collisions with larger animals. However, warning signs for smaller fauna that rarely damage vehicles, such as ocelots (Fig. 4.3), reptiles, and amphibians, are placed with a primary goal of enhancing connectivity for these faunae. Any time warning signs allow more fauna of any size to cross the roadway and avoid a wildlife vehicle collision, they are effectively enhancing connectivity.



**Figure 4.3. Ocelot crossing standard wildlife warning sign at Laguna Atascosa National Wildlife Refuge, Texas (Pomeroy 2017)**



**Figure 4.4. Deer crossing enhanced wildlife warning sign with blinkers (TAPCOnet.com 2019)**

or larger size (Fig. 4.4); (3) temporal wildlife warning signs, which are specific to a season or time of day through either placement or flashing lights (Fig. 4.5); and (4) animal detection system wildlife warning signs, which are signs with lights (typically flashing beacons) or lighted messages that are

Huisjer et al. (2015) divides wildlife warning signs into four types in order of increasing effectiveness for reducing vehicle wildlife collisions: (1) standard wildlife warning signs (Fig. 4.3); (2) enhanced wildlife warning signs, which include additional features to draw motorist attention, such as flashing lights



**Figure 4.5. Turtle crossing temporal wildlife warning sign with flashing beacon in Aurora, Canada (Seyidova 2019)**



**Figure 4.6. Elk crossing animal detection system wildlife warning sign with double flashing beacons near Payson, Arizona (Gray 2009)**

can be achieved by combining wildlife warning signs with mandatory speed reduction signs (see below). A combination of wildlife warning signs with rumble strips and roadside vegetation clearing appears to be effective in reducing roadkill in Tasmania (Lester 2015) (see Chapter 5.2.1). Animal detection wildlife warning signs are not recommended in areas of high traffic volume (> 20,000 vehicles/day) as they may increase the chance of rear end collisions when drivers attempt to avoid animals (Huisjer et al. 2015).

activated upon infrared detection of large animal movement near the roadway (Fig. 4.6). Studies have shown that standard and enhanced wildlife warning signs are generally ineffective at reducing roadkill. For larger animals, temporal wildlife warning signs can reduce wildlife vehicle collisions by 9-50%, and animal detection system wildlife warning signs can reduce collisions by 33-97%. Drivers tend to reduce speed by < 5 km/hr with temporal wildlife warning signs, and by  $\geq 5$ -22 km/hr with animal detection wildlife warning signs. Greater speed reduction



**Figure 4.7. Kangaroo crossing temporal wildlife warning sign with speed limit in Tasmania (Lehman and Ross 2018)**

### 4.1.2. Speed Reductions

Reducing vehicle speed through use of posted speed limit signs or speed bumps in roadkill hotspot areas can reduce the risk of vehicle wildlife collisions (Hobday and Minstrell 2008, Glista et al. 2009). This strategy is most suitable for rural roads with lighter traffic (Luell et al. 2003). Combining posted speed limit signs with temporal wildlife warning signs or animal detection system wildlife warning signs may be most



**Figure 4.8. Monarch crossing enhanced wildlife warning sign with speed limit sign in Coahuila State, Mexico (Zocalo.com.mx 2019)**

effective (Huisjer et al. 2015) (Fig. 4.7). However, monarch butterfly crossing enhanced wildlife warning signs combined with signage mandating a 60 km/hr (38 mph) speed limit reduction in the presence of migrating monarchs in northern Mexico have been ineffective in slowing traffic (Mora Alvarez et al. 2019, Zocalo.com.mx 2019) (Fig. 4.8)

### 4.1.3. Lane Closures

The temporary closure of both lanes of traffic on more rural roads can reduce roadkill during critical times of animal movement, such as for breeding amphibians or migrating ungulates. Single lane closures to reduce traffic in an area can be part of a traffic calming strategy (see below) to reduce traffic in roadkill hotspot areas (Luell et al. 2003). During the migration of purple crow butterflies over the Chingshue Brook Viaduct of National Freeway 3 in Taiwan (Chapter 2.1), car speeds can reach 100 km/hr (62 mph) and one of the outer lanes is closed to help reduce roadkill in conjunction with the temporary placement of 4 m high netting (Fig. 4.9) (TAFNB 2008, Taiwan EPA 2010). Highway workers monitor the number of butterflies crossing the viaduct, and when numbers go above 250 per minute, preparations are made for lane closure. When butterfly counts go above 300 per minute the outer lane is closed (TANFB 2014).

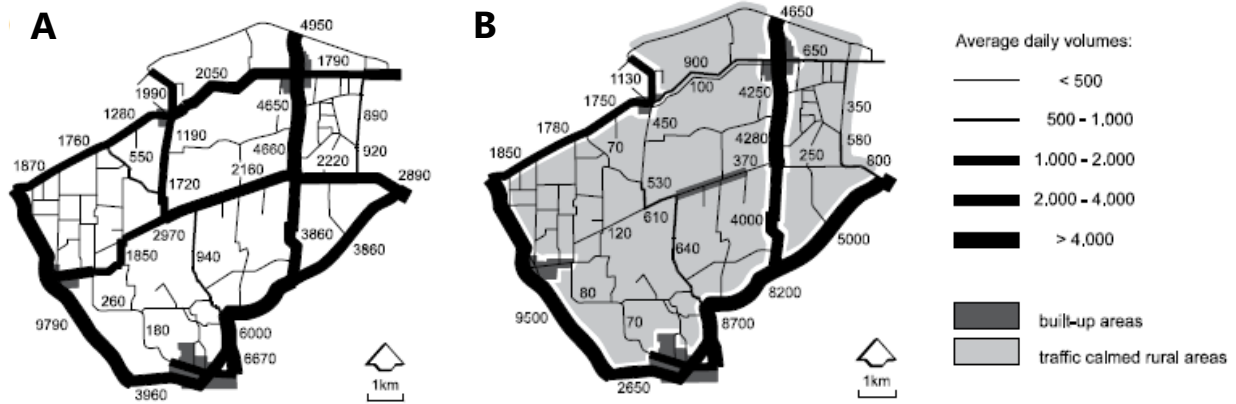


**Figure 4.9. Outer lane closure on Chingshue Brook Viaduct of National Freeway 3 in Taiwan during purple crow butterfly migration (TAFNB 2008)**



### 4.1.4. Traffic Calming

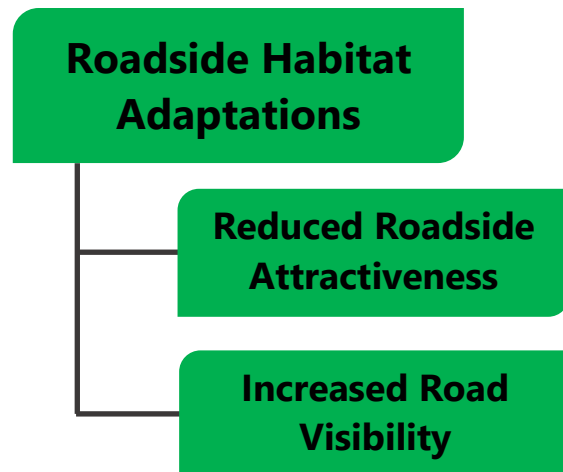
Traffic calming was originally conceived as regional traffic flow network planning to reduce traffic speed and volume on minor roads with heavier traffic diverted to major roads in order to reduce a variety of negative impacts to driver safety, infrastructure, and



**Figure 4.10. Ooststellingwerf region, Netherlands, before (A) and after (B) traffic calming to reduce roadkill in rural areas (modified from van Langeveld et al. 2009)**

wildlife along minor roadways (Jaarsma 1997) (Fig. 4.10). Regional road network planning in order to reduce traffic flow on minor roads requires that the minor road network be dense enough to allow diversion of travel flow onto a limited part of the network. Speed reduction and reduced width of selected minor roads is used to encourage greater traffic on selected arterial roads (van Langevelde and Jaarsma 2009). A wide variety of traffic calming measures are employed to increase safety for pedestrians and bicyclists in urban areas (USDOT-FHWA 2017, 2019), but few studies have evaluated traffic calming for reducing rural wildlife roadkill.

Models of traffic calming tied with metapopulation models of roe deer indicate significant increases in occupied deer habitat with larger areas of minor roads with reduced traffic volume (van Langevelde and Jaarsma 2009). Davey et al. (2017, 2018) developed several models incorporating animal migratory movement and roadkill with models varying traffic flow to minimize roadkill when designing roads through ecologically sensitive areas.



**Figure 4.11. Roadside habitat adaptation options for roadkill mitigation**

## 4.2. Roadside Habitat Adaptations

The habitat next to the roadway can be adapted to lower roadkill by either reducing attractiveness to wildlife or increasing visibility of the animals (luell et al. 2003) (Fig. 4.11).

### 4.2.1. Reduced Roadside Attractiveness

Earlier studies suggest that roadside habitat for insect pollinators (Fig. 4.12) provides a net benefit that balances mortality from roadkill (c.f., USDOT-FHWA 2016). More recent studies have questioned whether the benefits of attractive roadside habitat always outweigh pollinator roadkill costs. Keilsohn et al. (2018) found high pollinator roadkill



**Figure 4.12. Spring roadside flowers in East Texas (Dean 2015).**

adjacent to attractive lawn and meadow habitats and suggested further research is needed to determine whether these habitats serve as a source or sink for pollinator populations. Phillips et al. (2019) found that pollinator populations were significantly lower closer to the edge of the roadside, especially with higher traffic volume. Pollinator abundance was about 50% higher at 5 m from the roadside compared to the road edge, and 150% higher at 10 m from the roadside. Pollinator abundance was 100% higher

with traffic volumes of about 10 vehicles/30 min compared to 600 vehicles/30 min (their Fig. 3). Phillips et al. (2019) recommend regular mowing of the first several meters of roadside vegetation adjacent to the pavement in order to reduce pollinator attraction and maintaining an at least 2-meter wide area of roadside pollinator habitat outside of the mowed area, with a priority for lower traffic volume roadways (see Chapter 6.1.1.).

### 4.2.2. Increased Road Visibility

Lester (2015) employed roadside and table drain clearance to increase visibility of wildlife in combination with warning signage and auditory deterrents (rumble strips) to successfully reduce marsupial roadkill by 59% relative to controls along a Tasmanian roadway.



### 4.3. Road Infrastructure Adaptations

A variety of infrastructure adaptations have potential to reduce roadkill, including altered lighting, curb reductions, drainage escapes, wildlife jumpouts, adjustment to right of ways and medians, and road cuttings (luell et al. 2003) (Fig. 4.13). These adaptations are only treated briefly here, as most, with the possible exception of aerial flyouts and road cuttings, probably have little application to mitigation options related to butterflies.

#### 4.3.1. Altered Lighting

Reducing street lighting can lower roadkill for nocturnal insects attracted to the lights and the predatory birds and bats that feed on them (luell et al. 2003). In order to reduce mortality of federally endangered Indiana Bat for lighted intersections in construction of the U.S. Route 33 bypass in Ohio, the height of the lights was increased from 30 feet to 100 feet, requiring brighter bulbs, in order to reduce foraging of bats under lights near the traffic (Lloyd 2012).

#### 4.3.2. Reduced Curb Height

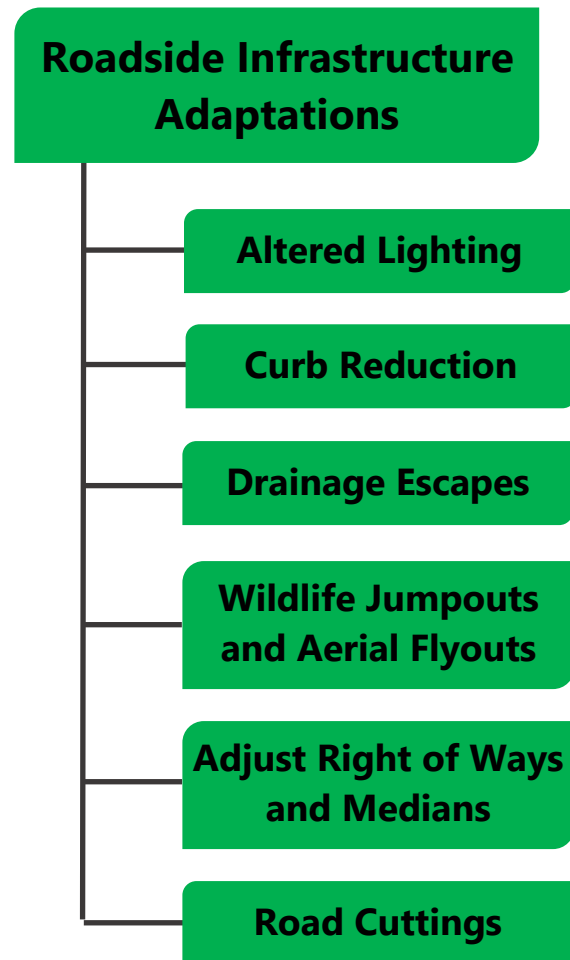
Roadway curbs can trap small amphibians, reptiles, mammals, and invertebrates on the road and potentially increase roadkill incidence. Sloping curbs and gaps can provide escape routes for small fauna (luell et al. 2003).

#### 4.3.3. Drainage Escapes

Smaller animals washed into roadway drains, particularly amphibians, can be provided drainage escapes in the form of ramps (luell et al. 2003).

#### 4.3.4. Wildlife Jumpouts and Aerial Flyouts

Wildlife jumpouts, or escape ramps, are structures designed to enable animals, usually ungulates, to escape roadways bounded on either side by barriers, such as wildlife exclusion fencing (Jensen 2018).



**Figure 4.13. Roadside infrastructure adaptation options for roadkill mitigation**

A similar concept, aerial flyouts, may assist flying fauna, including butterflies, in low flight patterns over the roadway encountering flight barriers on one or both edges of the roadway that increase the amount of time exposed to potential wildlife/vehicle collisions. Considering the directed southern flight of fall migratory monarch butterflies, it may be important to consider reducing the height of flight barriers consisting of tall vegetation or landscape features on the southern side of east/west roadways, or either side of north/south roadways, in order to facilitate lower roadway transit times over monarch roadkill hotspot areas.

#### *4.3.5. Adjustments in Right of Ways and Medians*

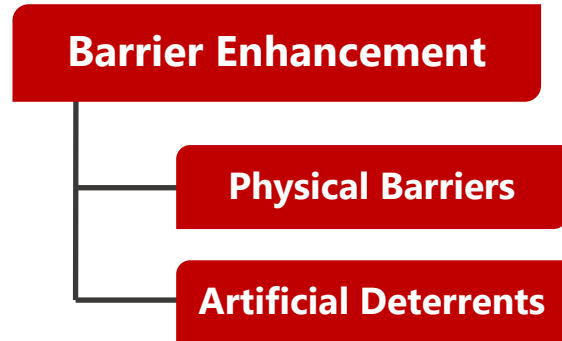
Concrete median barriers for traffic safety can trap smaller wildlife on the roadway and potentially increase roadkill. Potential solutions for roadkill hotspot zones include use of raised concrete barriers and more open and less rigid barrier designs, such as metal beam and cable barriers (Clevenger and Kociolek 2013).

#### *4.3.6. Road Cuttings*

Road cuttings may represent a barrier for some wildlife (Goosem 2009) (see Chapter 5), and grading out of cuttings to slopes, when practical, can provide better integration with the landscape form and connectivity in areas of lower roadkill (Iuell et al. 2003). Road cuttings may also serve beneficially as flight diverters for birds and insects, raising their elevation above the traffic as they cross the roadway.

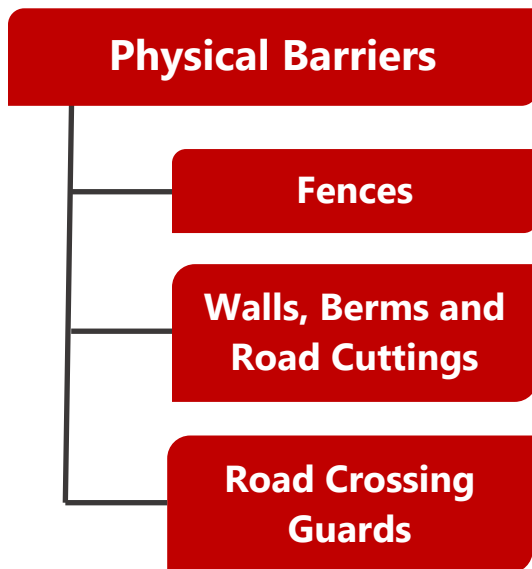
## CHAPTER 5. BARRIER ENHANCEMENT

Jackson and Fahrig (2011) simulated the effect of road mortality on genetic diversity and concluded that mitigation that prevents road mortality, such as barrier enhancements like fencing, can be more beneficial for maintaining genetic diversity in a declining population as opposed to increasing migratory success and connectivity, such as through wildlife crossings. In order to maintain both genetic and migratory connectivity for wildlife populations it is generally recommended to use barriers in conjunction with connectivity enhancement through wildlife crossings (luell et al. 2003, Van der Ree et al. 2015). Barrier enhancement can generally be divided into physical barriers and artificial deterrents (luell et al. 2003) (Fig. 5.1). Although physical barriers have not been implemented for flying insects, such as butterflies, their use is important for planning multi-species mitigation, such as wildlife crossing structures designed to enhance connectivity for a variety of wildlife in addition to butterflies.



**Figure 5.1. Barrier enhancement options for roadkill mitigation**

### 5.1. Physical Barriers



**Figure 5.2. Physical barrier options for roadkill mitigation**

Physical barriers to lower roadkill in hotspot zone can include fences, walls, berms, road cuttings, and road crossing guards (luell et al. 2003, Cramer and Flower 2017) (Fig. 5.2).

#### 5.1.1. Fences

Fences are primarily employed as a barrier to prevent larger animals from colliding with cars and reduce the number of small animal roadkill (luell et al. 2003). They are especially valuable for funneling animals towards wildlife crossing structures to maintain population connectivity across the roadway (van der Ree et al. 2015). luell et al. (2003) and van der Ree et al. (2015) provide detailed recommendations and specifications for use of fencing in roadkill mitigation for different types of animals and

situations. It is critical that the height and design of the fence be species appropriate. For example, fencing under 2 meters height was ineffective in guiding local medium to large sized animals to wildlife underpasses in Brazil (Ciocheti et al. 2017). Fences can serve as collision hazards for birds, and colored tape on the top of fencing can be used as a warning (Van der Ree et al. 2015).

Fences could also be employed for exclusion of aerial fauna if they are used to form an overhead tunnel, or fence tunnel, covering the roadway (Fig. 5.3). We are not aware of implementation of fence tunnels for aerial faunal roadkill mitigation. Fence tunnels would require a minimum overhead safety clearance for accommodating taller vehicles.

### 5.1.2. Walls, Berms, and Road Cuttings

A variety of alternatives to traditional fencing include concrete walls, soil berms, road cuttings, and dense vegetation plantings (Luell et al. 2013, van der Ree et al. 2015).

### 5.1.3. Road Crossing Guards

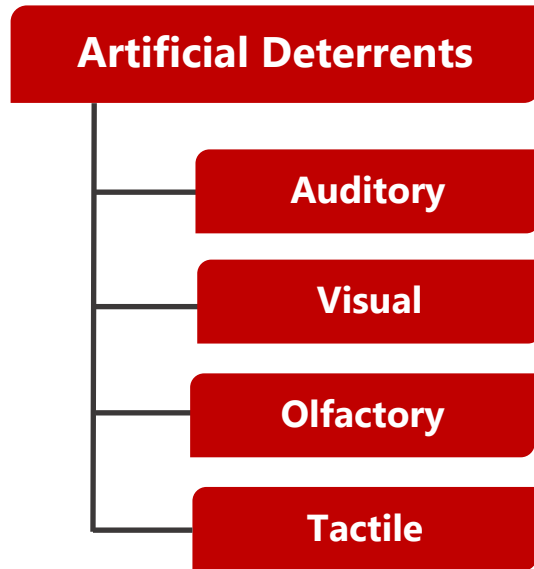
Ungated roadway intersections along fenced areas can be points where livestock and wildlife can enter roadways. Common barriers employed at ungated intersections include cattle guards, wildlife guards and electric mats (or electric cattle guards, considered as tactile deterrents below) (USDOT-FHWA and CFLHD 2011, Cramer and Flower 2017). These structures can be important to include for reinforcing large mammal/marsupial barriers near wildlife crossings.



**Figure 5.3. Chain link fence tunnel over bicycle trail in Cheyenne, Wyoming**  
(<http://steveandgeorgia.net/Weblog/?p=1460>).

## 5.2. Artificial Deterrents

Artificial deterrents to wildlife approaching of roads can be auditory, visual, olfactory, or tactile in nature (Luell et al. 2003, Cramer and Flower 2017) (Fig. 5.4). Various artificial deterrents can be combined for activation with approaching traffic to comprise a virtual fence system (e.g., Fox et al. 2019). More thorough evaluation is needed to determine the effectiveness of most artificial deterrents (e.g., Coulson and Bender 2019).



**Figure 5.4. Artificial deterrent options for roadkill mitigation**

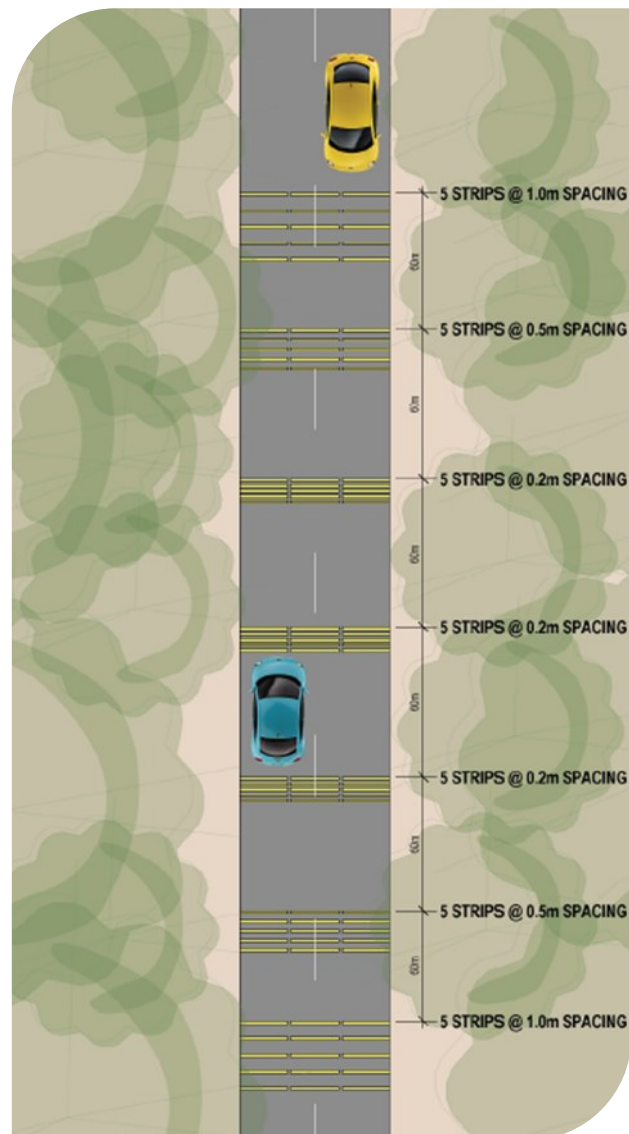
without rumble strips is needed to confirm their value.

### 5.2.2. Visual

Wildlife warning reflectors cast the light of approaching vehicles at night to the side of the road for warning wildlife. They are inexpensive, but studies reveal they have little if any efficacy for reducing roadkill (luell et al. 2003). Benten et al. (2018) tested several types of wildlife warning reflectors, including one in combination with an auditory deterrent, and found they were all ineffective in reducing roadkill. Some butterflies respond negatively to short range optical cues, such as male sulfur butterflies (*Colias* spp.) which avoid other males that flash UV reflecting wings to discourage rival males during mating (Silbergleid et al. 1978).

### 5.2.1. Auditory

Lester (2015) found that use of a series of 10 mm high thermoplastic rumble strips, in conjunction with wildlife warning signs and roadside vegetation clearing, resulted in a 59% reduction in roadkill in northwestern Tasmania. They hypothesized that the rumble strip noise served to warn animals of approaching traffic and alert drivers that they were entering a wildlife crossing when combined with signs. Further testing with and



**Figure 5.5. Rumble strip auditory deterrent for roadkill mitigation (Lester 2015)**



Long range optical repellent cues that might affect butterfly flight patterns around roadways are unknown.

### 5.2.3. Olfactory

Olfactory repellents have mainly been developed for deer in the form of mixed scents of humans, wolves, and other predators held in a foam carrier and applied to roadside trees or posts. Initial studies suggested they may be effective in increasing deer attentiveness in the vicinity of the repellent, but deer may simply move to cross the road in another area (luell et al. 2003).

Certain plants, such as pot marigold, appear to act as close-range repellents for oviposition by the imported cabbageworm butterfly, *Pieris rapae* (L.), (e.g., Jankowska et al. 2009). Assuming chemical repellents of monarchs could be identified, their long-range efficacy in outdoor windy environments would be doubtful in justifying the cost of their production and aerial dissemination.

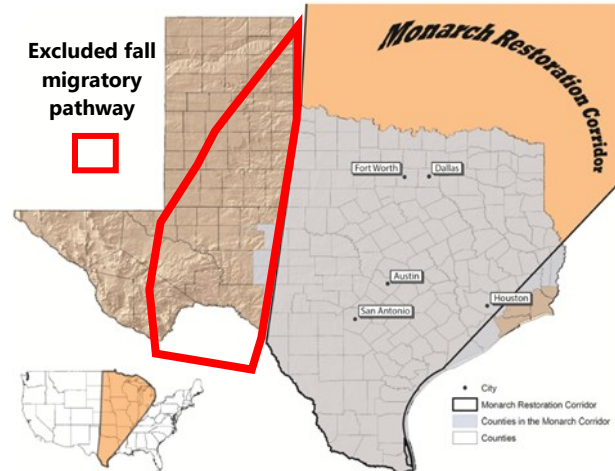
### 5.2.4. Tactile

Cramer and Flower (2017) evaluated electric mats in conjunction with cattle guards regarding their efficacy in repelling mule deer from crossing gaps in wildlife fencing around road crossings. They found double cattle guards and wildlife guards were just as effective or more effective than a combination of a single cattle guard and electric mat. Further testing of electric mats was recommended.

## CHAPTER 6. COMPENSATORY MITIGATION

Provision of nectar plant habitat for adult monarchs and milkweed plant habitat for larval monarchs are key goals of monarch habitat enhancement and restoration.

Monarch habitat enhancement and restoration projects in Texas are being supported by a cooperative effort between the Texas State Soil and Water Conservation Board (TSSWCB) and 143 Soil and Water Conservation Districts with funding from the National Fish and Wildlife Foundation and the U.S. Department of Agriculture Natural Resources Conservation Service (USDA-NRCS) (TSSWCB 2016) (Fig. 6.1). The Texas project area encompasses the primary monarch spring migration corridor in Texas (Journey North 2019) as well as a large portion of the primary monarch fall migration corridor (Fig.

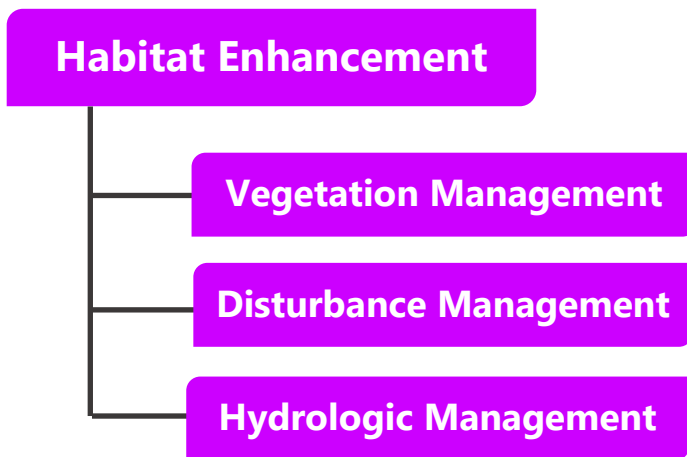


**Figure 6.1. Monarch habitat enhancement and restoration project area for the Texas Soil and Water Conservation Board (modified from TSSWCB 2016)**

1.6). An about 250 km wide area of the western fall migratory pathway is excluded from the project area (Fig. 6.1, red). The TSSWCB projects are targeted to private landowners.

Rights of ways for roadsides, railways, and utilities comprise another large area in Texas that can be targeted for monarch habitat habitat enhancement and restoration. The Texas Department of Transportation (TxDOT) Wildflower Program benefits monarch habitat in roadside right of ways in Texas through mowing schedules that preserve

spring wildflowers and wildflower seeding (TxDOT 2019).



**Figure 6.2. Habitat enhancement options for roadkill mitigation**

### 6.1. Habitat Enhancement

Habitat enhancement involves improving the quality of existing milkweed stands in grassland herbaceous habitats for monarch larvae, and improving nectar plant availability, including milkweeds, for monarch adults. Kasten et al. (2016) found milkweeds on 60% of roadside





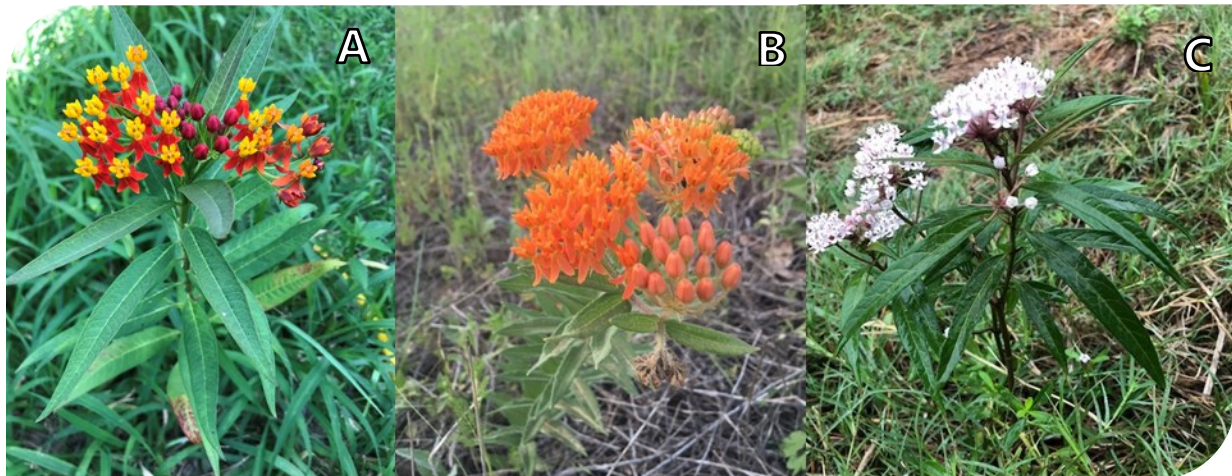
**Figure 6.3. Four important milkweed hosts for monarch butterflies in Texas in the spring and fall, including three spring peak bloomers, (A) *Asclepias asperula* var. *asperula*, (B) *A. viridis*, (C) *A. latifolia*, and one fall peak bloomer, and (D) *A. oenotheroides* (iNaturalist 2021)**



transects in the Upper Midwest, and suggested that protection and enhancement of existing roadside milkweed habitat should take precedence over habitat restoration involving planting of new milkweeds. The primary tools for supporting existing nectar and milkweed plant resources are enhancement of vegetation, disturbance regimes, and hydrology (Fig. 6.2).

The four most important milkweeds in Texas for providing larval habitat and adult nectar resources for monarchs are *Asclepias asperula* var. *asperula* (antelopehorns), *A. viridis* (green milkweed), *A. oenotheroides* (zizotes), and *A. latifolia* (broadleaf milkweed) (NRCS 2015a; Tracy et al. 2022) (Fig. 6.3) (Table 6.1). These four species are the most common on roadsides in Texas, along with occasional *A. viridiflora* (green comet milkweed), from the southeastern to northwestern portion of the state, and *A. verticillata* (whorled milkweed) in East Texas (Part II Chapter 3). *Asclepias a. var. asperula* and *A. viridis* mostly flower in the spring (March-June), but can flower in the fall with favorable rains. *Asclepias oenotheroides* primarily flowers from April to September, with peak flowering in September. *Asclepias latifolia* mostly flowers in late spring and summer (May-July) (iNaturalist 2021).

*Asclepias curassavica* (tropical milkweed) (Fig. 6.4A) is native from Florida to South America, but it is widely cultivated in the southern U.S. (GBIF.org 2019), especially for butterfly gardens (Singhurst et al. 2015). Tropical milkweed blooms year-round, with peak bloom in April (iNaturalist.org 2019). Unlike most native milkweeds in Texas, with the exception of declining coastal *A. perennis* (Singhurst et al. 2015, iNaturalist.org 2019), tropical milkweeds can continue growing under mild winter conditions in coastal southern U.S., increasing the population of winter resident monarchs and leading to high levels of protozoan parasites *Ophryocystis elektroscirrha* (OE). These resident monarchs can spread OE to migrant monarchs (Satterfield et al. 2018). Consequently, Monarch Joint Venture (2019a) recommends cutting back tropical milkweeds in the fall



**Figure 6.4. Three showy milkweed hosts for monarch butterflies, (A) *Asclepias curassavica*, (B) *A. tuberosa*, and (C) *A. perennis* (iNaturalist 2021)**

or winter where it is not native, and including native milkweeds in gardens. Native showy milkweeds for enhancing monarch habitat in urban gardens include *A. tuberosa* (butterfly weed) in Central and East Texas (Singhurst et al. 2015), which blooms from May to October with peak bloom in June to July (iNaturalist 2021), and *A. perennis* (aquatic milkweed) in eastern coastal Texas (Garren-McKillip 2016), which blooms year round with peak bloom from April to October (iNaturalist 2021) (Fig. 6.4B-C).

The USDA-NRCS (2015b) has developed a list of recommended native monarch nectar plants for spring and fall in the South-Central US, including Texas. We refined this list using additional publications to identify sixteen highly desirable monarch nectar plants for the spring and fall migrations common in various regions of the Central and Coastal monarch migratory funnels of Texas (modified from Kantola et al. in prep.) (Table 6.1). This monarch nectar plant list includes 12 non-milkweed species and four milkweeds discussed above. Of the 12 non-milkweed nectar plants, two are herbaceous and one a shrub with peak bloom in the spring, two of which also bloom in the fall (Fig. 6.5), two are herbaceous with peak bloom in the fall but also blooming in the spring (Fig. 6.6), and seven have peak bloom in the summer and fall, including three *Baccharis* sp. shrubs (Figs. 6.7) and four herbs (Fig. 6.8) (iNaturalist 2021). Poor seasonal rainfall can limit flowering, especially for summer/fall bloomers.

Of the six listed nectar plants valuable to monarchs with peak bloom in spring, half are milkweeds (Table 6.1). Several of the well-known common spring blooming roadside wildflowers in central and eastern Texas are not considered valuable to monarchs (USDA NRCS 2015b). For example, *Lupinus texensis* (Texas Bluebonnet) does not produce nectar and is mainly pollinated by bees (Schaal 1980). *Castilleja indivisa* (Texas Indian Paintbrush) produces nectar that attracts some butterflies, but is primarily pollinated by black-chinned hummingbirds (Adler 2000) and bumblebees (Adler 2003). *Oenothera speciosa* (pink evening primrose) is not known to be attractive to nymphalid butterflies, such as monarchs, but produces nectar primarily attracting butterflies of the family Hesperiidae (skippers), with lower attraction for butterflies from the families Pieridae (whites and sulphurs) and Papilionidae (swallowtails) (Wolin et al. 1984).

**Table 6.1. Sixteen native nectar plant species valuable to monarch butterflies in Texas, including major larval host plants, flowering periods, and distribution in fall monarch migratory pathways.**

Nectar Plant Species (* = Monarch Larval Host Plant)	Value as Monarch		Distribution in Fall Migratory Funnels <sup>b</sup>		Source for Nectar Value
	Nectar Plant	Flowering Period <sup>a</sup>	Central Funnel	Coastal Funnel	
<b><i>Spring Only Blooming</i></b>					
<i>Verbena halei</i> (Texas vervain)	High	Mar-Jun (peak Apr)	All	All	USDA NRCS 2015b



**Table 6.1. Sixteen native nectar plant species valuable to monarch butterflies in Texas, including major larval host plants, flowering periods, and distribution in fall monarch migratory pathways.**

Nectar Plant Species (* = Monarch Larval Host Plant)	Value as Monarch		Distribution in Fall Migratory Funnels <sup>b</sup>		Source for Nectar Value
	Nectar Plant	Flowering Period <sup>a</sup>	Central Funnel	Coastal Funnel	
<b>Spring Peak and Fall Blooming</b>					
* <i>Asclepias asperula</i> var. <i>asperula</i> (antelopehorns)	Very High <sup>c</sup>	Mar-Oct (peak Apr- May)	Central and Northern	Central	USDA NRCS 2015b
* <i>Asclepias latifolia</i> (broadleaf milkweed)	Very High <sup>c</sup>	May-Sep (peak Jun)	Central and Northwestern	--	USDA NRCS 2015b
* <i>Asclepias viridis</i> (green milkweed)	Very High	Mar-Oct (peak May)	North Central	Eastern	USDA NRCS 2015b
<i>Glandularia</i> <i>bipinnatifida</i> (prairie verbena)	High	Feb-Nov (peak Apr)	All	Northeast and South	USDA NRCS 2015b
<i>Sidneya tenuifolia</i> (= <i>Viguiera stenoloba</i> ) (skeletonleaf goldeneye) (shrub)	High	Jan-Jun, Nov-Dec (peak Apr, Jun)	Central, Southwest	South	USDA National Park Service (NPS) 2015
<b>Fall Peak and Spring Blooming</b>					
* <i>Asclepias</i> <i>oenotheroides</i> (zizotes)	Very High <sup>c</sup>	Mar-Nov (primarily Apr-Sep, peak Sep)	Central and Southern	Western	USDA NRCS 2015b
<i>Conoclinium</i> <i>coelestinum</i> (blue mistflower)	Very High	Mar-Dec (peak Sep)	East Central and Northeast	East	USDA NRCS 2015b
<i>Verbesina enceliodes</i> (cowpen daisy)	Very High	Feb-Dec (peaks Apr and Sep)	Northeast, Central, and Southwest	South	USDA NRCS 2015b
<b>Summer/Fall Peak Blooming</b>					
<i>Baccharis neglecta</i> (Roosevelt weed) (shrub)	Very High	Sep-Nov (peak Oct)	Northeast and East Central	South	USDA NRCS 2015b
<i>Baccharis halimifolia</i> (groundsel tree) (shrub)	Very High <sup>c</sup>	Sep-Dec (peak Oct)	--	East	USDA NRCS 2015a, Brown and Coopridier 2011
<i>Baccharis salicina</i> (willow Baccharis) (shrub)	Very High <sup>c</sup>	Aug-Nov (peak Aug)	West Central and Southwest	--	USDA NRCS 2015b

**Table 6.1. Sixteen native nectar plant species valuable to monarch butterflies in Texas, including major larval host plants, flowering periods, and distribution in fall monarch migratory pathways.**

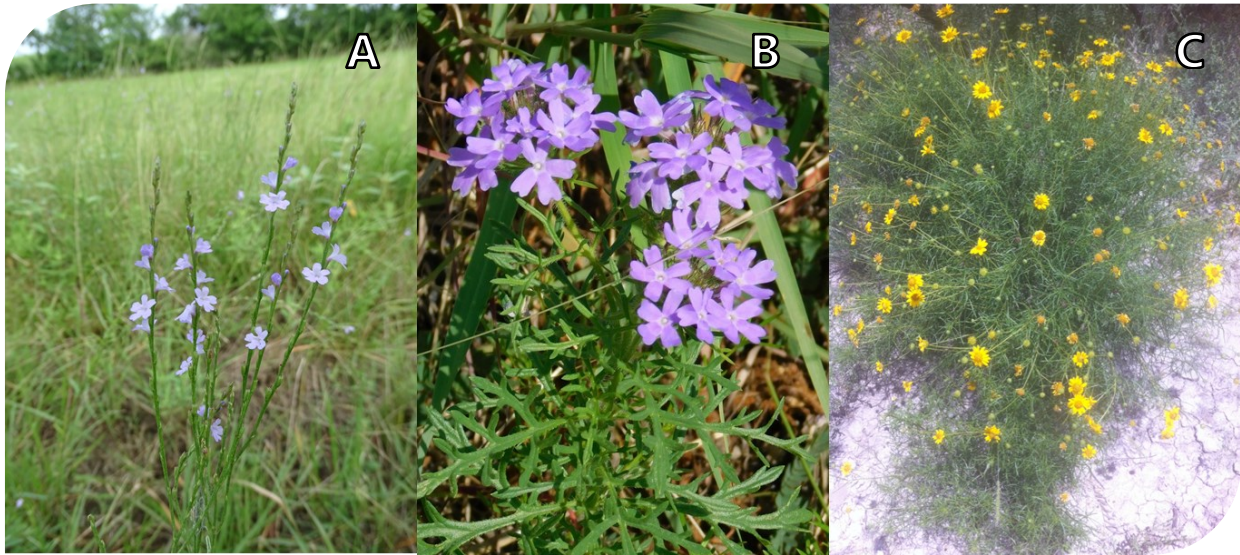
Nectar Plant Species (* = Monarch Larval Host Plant)	Value as Monarch		Distribution in Fall Migratory Funnels <sup>b</sup>		Source for Nectar Value
	Nectar Plant	Flowering Period <sup>a</sup>	Central Funnel	Coastal Funnel	
<i>Helianthus maximiliani</i> (Maximilian sunflower)	Very High	Jul-Oct (peak Aug-Oct)	Central and North	East	USDA NRCS 2015b
<i>Liatris punctata</i> (dotted blazing star)	Very High	Jul-Oct (peak Aug)	Central and North	Northeast	USDA NRCS 2015b
<i>Solidago altissima</i> (tall goldenrod)	High	Aug-Nov (peak Sep)	East	East	Ajilvsgi 2013
<i>Verbesina virginica</i> (frostweed)	High	Aug-Dec (peak Oct)	Central, North	East	USDA NRCS 2015b

<sup>a</sup>Flowering periods from USDA NRCS (2015a), Ajilvsgi (2013), Lady Bird Johnson Wildflower Center (2016), Singhurst et al. 2015, and iNaturalist.org (2019).

<sup>b</sup>Migratory funnels from Tracy et al. (2019) (Fig. 1.6) and general distributions from Kartesz (2015) and iNaturalist.org (2019).

<sup>c</sup>Nectar value assumed same as congener.

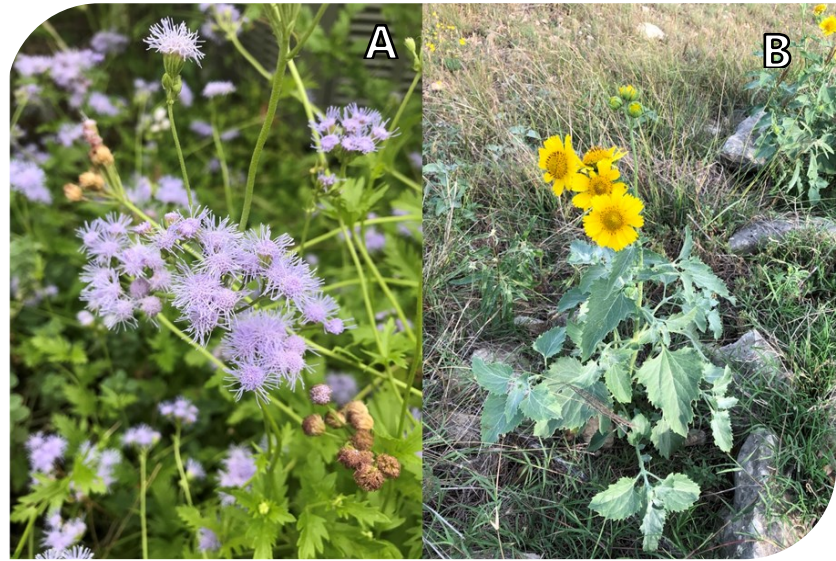
### 6.1.1. Vegetation Management



**Figure 6.5. Three spring peak blooming nectar plants valuable for monarchs in Texas, including (A) *Verbena halei*, blooming only in spring, and spring and fall blooming (B) *Glandularia bipinnatifida* and (C) *Sidneya tenuifolia* (= *Viguiera stenoloba*) (iNaturalist 2021)**

Vegetation management recommendations specifically for monarch butterfly habitat on agricultural lands are available from the USDA-NRCS (2015a). They emphasize increasing and maintaining plant species richness through practices such as brush management (USDA-NRCS and USDI-FWS 2016). General habitat enhancement guidelines for insect pollinators are also available for roadsides (Hopwood et al. 2015; USDOT-FHWA 2015, 2016; Jakobssen et al. 2018), and federal lands (USDA and USDI 2015). Six state DOTs, including TxDOT, have agreed to monarch habitat conservation to contribute to migratory connectivity along the IH-35 “Monarch Highway” (Monarch Joint Venture 2019b).

In order to avoid attracting pollinators to roadway edges where they may be subject to roadkill, Phillips et al. (2019) recommend that any roadside pollinator habitat be at least several meters from the edge of the payment. In addition, they recommend that pollinator habitat be at least 2 meters wide and preferably in areas of lower traffic volume. Milton et al. (2015) also recommends that compensatory habitat enhancement in general be located away from roadways, citing the negative effects of road agencies constructing compensatory wetlands adjacent to roadways where they attract amphibians and waterfowl to an area of higher roadkill risk.



**Figure 6.6. Two fall peak blooming nectar plants valuable for monarchs in Texas that also bloom in the spring, (A) *Conoclinium coelestinum* and (B) *Verbena virginica* (iNaturalist 2021)**

### 6.1.2. Disturbance Management

Probably the primary tools for enhancing milkweed and nectar habitats are the prevention of domination by invasive grasses and woody plants through the use of disturbance regimes to which native prairie herbs are well adapted. The four important milkweeds in Texas (Fig. 6.3) thrive under historical prairie conditions with disturbances from bison grazing and wildfires, but are poorly adapted for hay and cropland management (USDA-NRCS 2015a, Tracy et al. 2022). Maintaining appropriate levels of disturbance through prescribed cattle grazing, prescribed burning, light disking, and summer mowing (Fig. 6.9) can stimulate these milkweeds and other nectar plants important for monarchs (Baum and Sharber 2012, USDA-NRCS 2016). In Oklahoma, late season sustained mowing of grasslands in June and September, or September alone,





**Figure 6.7. Three *Baccharis* shrubs important as monarch fall nectar sources in Texas, (A) *B. halimifolia*, (B) *B. salicina*, and (C) *B. neglecta* (iNaturalist 2021)**

increased the cover of broadleaf species such as *A. viridis*, while suppressing invasive KR bluestem (Dee et al. 2016). Disturbance enhancement is integral to the USDA-NRCS (2015a) recommended practice of early successional habitat development and management for farmlands, and is also recommended for highway right of ways (Hopwood et al. 2015). The Texas Department of Transportation (TxDOT) Wildflower





**Figure 6.8. Four summer/fall peak blooming nectar plants valuable for monarchs in Texas, (A) *Helianthus maximiliani*, (B) *Liatris punctata*, (C) *Solidago altissima*, and (D) *Verbesina virginica* (iNaturalist 2021)**



Program (TxDOT 2019) includes mowing after spring and fall flowers have gone to seed



**Figure 6.9. TxDOT roadside mowing (TxDOT 2018a)**

(e.g., MJV 2016), and mowing at minimum seven-inch height to reduce stress to vegetation such as perennial milkweeds (TxDOT 2018a, Markwardt 2018).

Timing of disturbance is critical for optimal roadside butterfly habitat use. For example, mowing too early in the season reduced roadside butterfly abundance in Finland (Valtonen and Saarinen 2005). During the spring migration when monarch roadkill is lower (Kantola et al. 2019) and females are

laying more eggs on roadside milkweed, it is beneficial to curtail mowing until past June in Texas in order to allow monarch larvae to complete development on milkweeds (Fig. 6.10). Monarch Joint Venture (2016) recommends avoiding mowing roadsides in the South (below 35°N) during March through June, in order to allow offspring of the spring migrants to develop. In addition, they recommend avoiding mowing from early August to October in order to allow larvae of pre-migrants to develop. Knight et al. (2019) found that mowing the rhizomatous perennial common milkweed (*Asclepias syriaca*) in Canada one to three weeks before monarch peak egg laying could stimulate milkweed growth and lead to increased monarch egg populations in younger regrowth of mown milkweed compared to older growth unmown milkweed.



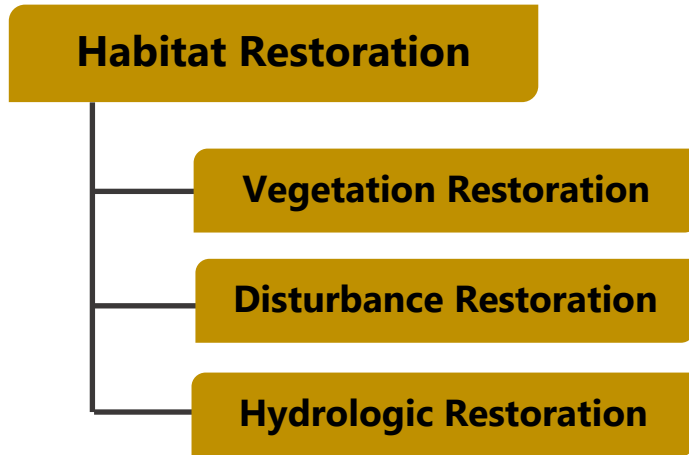
**Figure 6.10. Monarch larva on milkweed by roadside (Davis 2017)**

### 6.1.3. Hydrologic Management

Urban habitats of milkweeds and nectar plants can provide significant habitat for monarchs and other pollinators (Johnston et al. 2019, Lewis et al. 2019). Texas urban areas in particular include disturbed habitats favored by native milkweeds (Tracy et al. 2022). These urban habitats have the advantage of greater water resources that can sustain habitats in drier years or seasons, particularly for the fall migration.

## 6.2. Habitat Restoration

Recommendations for restoration of milkweeds and nectar plants for monarchs are provided for farmlands by the USDA-NRCS (2015a), and for right of ways by Hopwood et al. (2015). As with habitat enhancement, vegetation, disturbance regimes, and hydrologic factors can all be important for restoration (Fig. 6.11).



**Figure 6.11. Habitat restoration options for roadkill mitigation**

### 6.2.1. Vegetation Restoration

The USDA-NRCS (2015a) recommends a variety of monarch habitat restoration activities on farmland, including conservation cover and range planting (USDA-NRCS and USDI-FWS 2016) (Fig. 6.12). Hopwood et al. (2015) provides guidelines for restoring pollinator habitat on highway right of ways, such as assessment of site conditions and existing plants of various blooming periods, and selection of nectar plants adapted to the site to provide seasonal bloom diversity. The TxDOT Wildflower Program includes seeding of roadsides disturbed by construction activity with regionally specific native plant species (TxDOT 2019). TxDOT has also partnered with USDI FWS and the Native Plant Society of Texas to establish at least four monarch gardens of milkweeds and nectar plants at



**Figure 6.12. Frontier Conservation Seeder for tilling and seeding a wildflower meadow (JohnDeere.com 2019)**

safety rest stops, including along Interstate Highway 35 (Texas Parks and Wildlife Department [TPWD] 2016) (Markwardt 2018) (Fig. 6.13). Best management practices for urban milkweed and nectar plant propagation for monarch conservation have been developed by the National Wildlife Foundation and implemented in many cities, including several in Texas (Fitzgerald 2015).

Milkweed restoration in Texas, including both propagation and planting, is promoted by a variety of

organizations, such as The Xerces Society (Borders and Lee-Mäder 2014), Monarch

Watch (2017), and Monarch Joint Venture (2017a). Milkweeds are generally planted as seeds or transplants in areas where the existing vegetation has been cleared, such as through shallow cultivation and repeated applications of herbicide (Luna and Karsten Dumroese 2013; Borders and Lee-Mäder 2014, 2015).

Monarch habitat enhancement and restoration in much of the monarch western fall migratory pathway is not covered by the TSSWCB (2016) project, and monarchs migrating through this area could especially benefit from additional fall nectar resources in dry years. The possibility of other projects providing additional nectar plant and milkweed restoration in the western fall flyway of Texas should be investigated.

### 6.2.2. Disturbance Restoration

Disturbance restoration will likely require artificial maintenance similar to that prescribed in monarch habitat enhancement for restored farmlands (USDA-NRCS 2015) and roadsides (Hopwood et al. 2015).

### 6.2.3. Hydrologic Restoration

Semiarid prairie milkweed and nectar plant habitats do not generally require hydrologic restoration, but their establishment can benefit from supplementary water where available, especially in drier years or seasons. For example, roadside watering can be important in establishing planted right of way vegetation (University of Minnesota- Center for Transportation Studies [UNM-CTS] 2017) (Fig. 6.14).



**Figure 6.13. TxDOT Monarch waystation design for IH-35 (Markwardt 2018)**

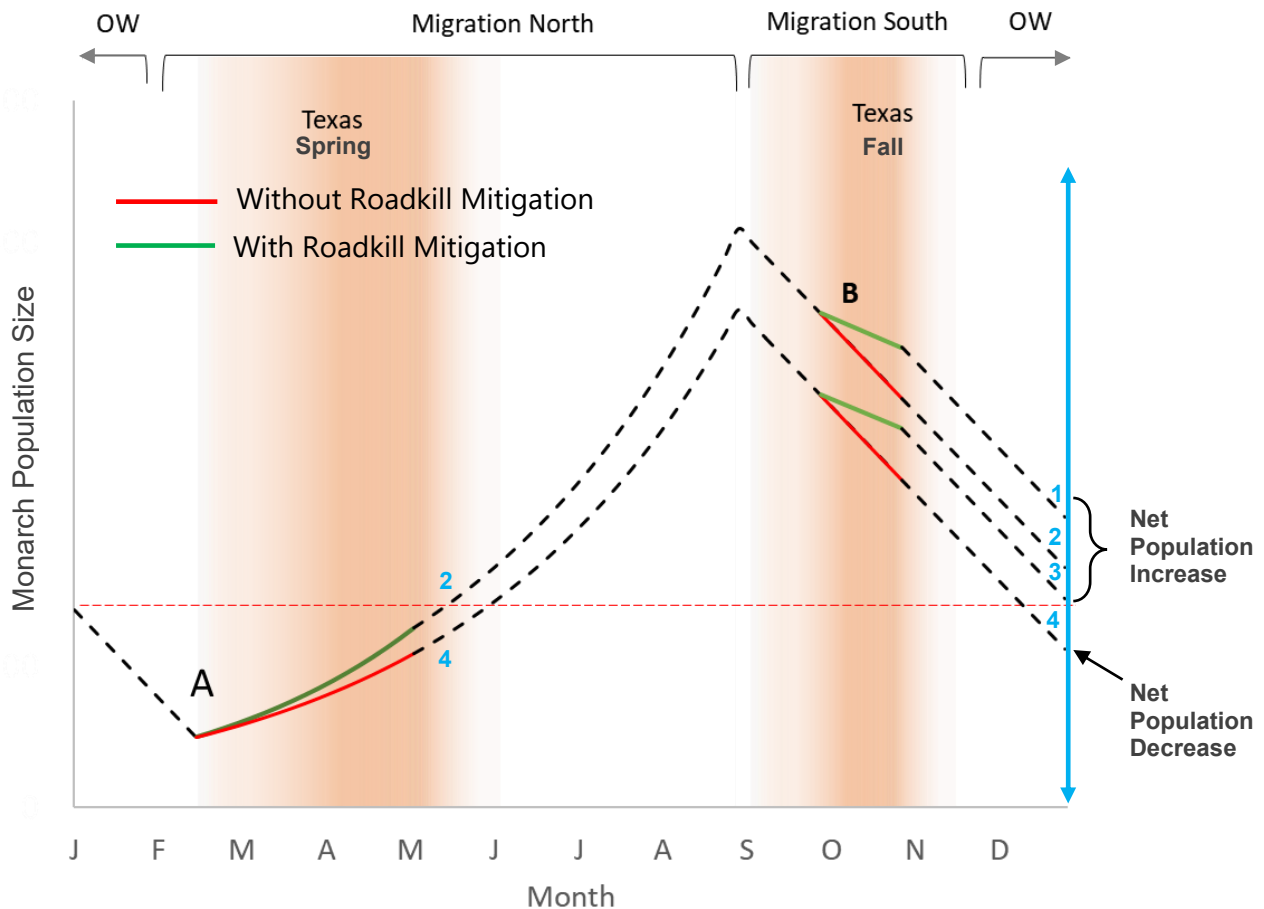


**Figure 6.14. MnDOT roadside watering of turf plantings (UNM-CTS 2017)**

## CHAPTER 7. POTENTIAL MONARCH ROADKILL MITIGATION STRATEGIES ON TEXAS ROADWAYS

### 7.1. Developing an Effective Roadkill Mitigation Strategy

The ultimate goal for any monarch roadkill mitigation strategy is to aid in the recovery of the eastern migratory population, contributing to a reduction or reversal in the 7% annual population decline (see Chapter 1.5.2). Multiple direct or indirect (compensatory) monarch roadkill mitigation measures at different times of year in Texas can have a much greater impact on increasing monarch populations than a single mitigation action (Fig. 7.1). Also, mitigation in the spring can potentially result in greater annual population growth than later season mitigation in the fall (Fig. 7.1). An example of



**Figure 7.1. Conceptual model of how monarch roadkill mitigation options in Texas for the spring and fall could affect monarch population recovery. This model is solely illustrative and does not reflect actual seasonal trends in the monarch population. OW = Overwintering; A = Spring Mitigation; B = Fall Mitigation; Dashed Population Trend Lines: 1 = Spring and Fall Mitigation; 2 = Spring Mitigation Only; 3 = Fall Mitigation Only; 4 = No Mitigation.**



combining spring and fall mitigation could include compensatory mitigation to increase both spring and fall roadside milkweed populations for larval food and adult nectar as well as other adult nectar resources, such as Texas vervain in the spring and goldenrod in the fall. Development of a successful monarch roadkill mitigation strategy will probably involve selecting a mix of spring vs fall mitigation actions that can most efficiently contribute to recover of the eastern migratory monarch population.

This chapter will examine six direct and seven indirect (compensatory) monarch roadkill mitigation strategies. Three of the compensatory strategies currently implemented by TxDOT, while the other strategies could possibly be implemented in the future within. General examples of the two major mitigation categories for monarch include:

- Direct mitigation – activities that directly reduce the amount of monarch roadkill through enhancement of either connectivity or barriers, such as flight diverters or seasonal advisory speed reduction which might increase connectivity at fall monarch roadkill hotspots along TxDOT ROWs
- Indirect or compensatory mitigation – activities that generally increase monarch population size and could be useful for offsetting roadkill mortality, including conserving or increasing monarch adult and larval food resources along TxDOT ROWs or in specially purchased mitigation lands outside of TxDOT ROWs

## 7.2. Direct Mitigation of Monarch Roadkill in Texas

A wide variety of types of direct roadkill mitigation solutions were examined in Chapter 2-5, some of which may be useful for reducing monarch roadkill. In this section, we consider the advantages and disadvantages of six potential direct mitigation types for Texas monarch roadkill that are the most feasible for implementation: five connectivity enhancements (two overpass wildlife crossings and four traffic adaptations), and one barrier enhancement (Table 7.1). Direct mitigation can be most effective where the location of yearly hotspot areas can be most precisely identified, such as in the case of direct mitigation for purple crow butterflies crossing over the Linnei Park bridge in Taiwan (Chapter 2.1). Monarch roadkill hotspots can be identified as regularly yearly occurring in regional areas in the Central and Coastal funnels, but their precise locations are unpredictable from year to year, and in some years, hotspots may be uncommon in the Central Funnel or absent in the Coastal Funnel (see Chapter 1.2.1; Fig. 1.11). This lack of precise regular monarch roadkill hotspot locations is a strong disadvantage for all six of the potential direct mitigation strategies, particularly those that are most expensive and difficult to implement (Table 7.1). Consequently, we currently only further consider below the two least expensive potential direct mitigation strategies involving traffic adaptations of seasonal warning signs or seasonal combination warning/speed advisory signs.

**Table 7.1. Potential monarch roadkill direct mitigation strategies for Texas.<sup>a</sup>**

Direct Mitigation Strategy (Categories)	Advantages	Disadvantages
<i>Connectivity Enhancements</i>		
<i>Overpass Wildlife Crossings</i>		
Temporary Mesh Flight Diverters (Installed During Fall Migration Only) (Chapter 2.1)	<ul style="list-style-type: none"> <li>• Could redirect flight for majority of monarchs above traffic in roadkill hotspot areas</li> </ul>	<ul style="list-style-type: none"> <li>• Annual monarch roadkill hotspot locations are too unpredictable for locating shorter lengths of flight diverter placement</li> <li>• The expense of engineering design and seasonal installation of longer lengths of flight diverters in view of the uncertainty of hotspot locations may be prohibitive</li> <li>• Airflow currents around netting may pull monarchs down into traffic and would need further study</li> <li>• Potential reduction in driver safety would need to be studied and minimized</li> </ul>
Permanent Wildlife Overpass (70m width) with Monarch Preferred Nectar Plantings (Chapters 1.2.1.1.1; 2.3)	<ul style="list-style-type: none"> <li>• Could attract majority of monarchs in a roadkill hotspot region flying within a 400m (481 yd) perceptual range to cross above the roadway while providing nectar resources</li> <li>• Placement could be optimized to benefit other wildlife, such as ungulates, also increasing vehicle passenger safety, and species of conservation concern, such as mountain lions and Texas horned lizards</li> </ul>	<ul style="list-style-type: none"> <li>• Annual monarch roadkill hotspot locations are too unpredictable for guaranteeing high use within a 400 m effective radius</li> <li>• Prohibitive expense (&gt;\$5 million) of engineering design and installation, especially in view of the uncertainty of hotspot locations</li> </ul>

**Table 7.1 (cont.). Potential monarch roadkill direct mitigation strategies for Texas.<sup>a</sup>**

Direct Mitigation Strategy (Categories)	Advantages	Disadvantages
<i>Traffic Adaptations</i>		
Seasonal Warning Speed Feedback Sign with Double Flashing Beacon (Fall Migration Only) (Chapter 4.1.1)*	<ul style="list-style-type: none"> <li>• Could influence motorists to reduce speed in roadkill hotspot region and reduce monarch roadkill incidence</li> <li>• Relatively inexpensive compared to other alternatives</li> </ul>	<ul style="list-style-type: none"> <li>• Warning signs for monarch crossings are considered ineffective in Mexico</li> <li>• Would require placement over large areas of monarch roadkill hotspot regions due to unpredictability of hotspots effective compliance only within 1 km of signage</li> <li>• Potential reduction in driver safety would need to be studied and minimized</li> </ul>
Seasonal Advisory (Optional) Speed Feedback Sign Combined with Warning Sign (Fall Migration Only) (Chapter 4.1.2)*	<ul style="list-style-type: none"> <li>• Generally considered more affective in slowing traffic speed and reducing roadkill than warning signs alone</li> <li>• Relatively inexpensive compared to other alternatives</li> </ul>	<ul style="list-style-type: none"> <li>• Speed reduction/warning signs for monarch crossings are considered ineffective in Mexico</li> <li>• The minimum speed limit reductions required to effectively reduce monarch road mortality needs further study</li> <li>• Would require placement over large areas of monarch roadkill hotspot regions due to unpredictability of hotspots and effective compliance only within 1 km of signage</li> <li>• Potential reduction in driver safety would need to be studied and minimized</li> </ul>
Traffic Calming -Reduce Traffic Volume for Roadkill Hotspots along Minor Roads using Speed Reduction to Encourage with	<ul style="list-style-type: none"> <li>• Reduction of traffic volume in hotspot regions can theoretically significantly reduce monarch roadkill</li> <li>• Relatively inexpensive compared to other alternatives</li> </ul>	<ul style="list-style-type: none"> <li>• Road networks in monarch roadkill hotspot regions of West Texas are probably not dense enough to allow diversion of traffic flow from minor roadways</li> <li>• Diversion of traffic onto major roadways in hotspot regions would theoretically transfer more roadkill to major roadways</li> <li>• Would require implementation over large areas of monarch roadkill hotspot regions due to unpredictability of hotspots</li> </ul>

**Table 7.1 (cont.). Potential monarch roadkill direct mitigation strategies for Texas.<sup>a</sup>**

Direct Mitigation Strategy (Categories)	Advantages	Disadvantages
Rerouting to Major Roads (Chapter 4.1.4)		<ul style="list-style-type: none"> <li>• Potential reduction in driver safety would need to be studied and minimized</li> </ul>
<i>Barrier Enhancements</i>		
<i>Physical Barriers</i>		
Permanent Mesh Fence Tunnel (Chapter 5.1.1)	<ul style="list-style-type: none"> <li>• Could redirect monarchs to less dangerous road crossing areas, such as where road cuts may naturally divert monarch flight above the traffic</li> </ul>	<ul style="list-style-type: none"> <li>• Annual monarch roadkill hotspot locations are too unpredictable for locating barrier placement</li> <li>• The expense of constructing a mesh fence tunnel would be prohibitive, especially considering the potential length needed to divert monarchs to a safer crossing area</li> <li>• Potential reduction in driver safety would need to be studied and minimized</li> </ul>

<sup>a\*</sup>Indicates mitigation strategy for monarchs that is further examined in text.

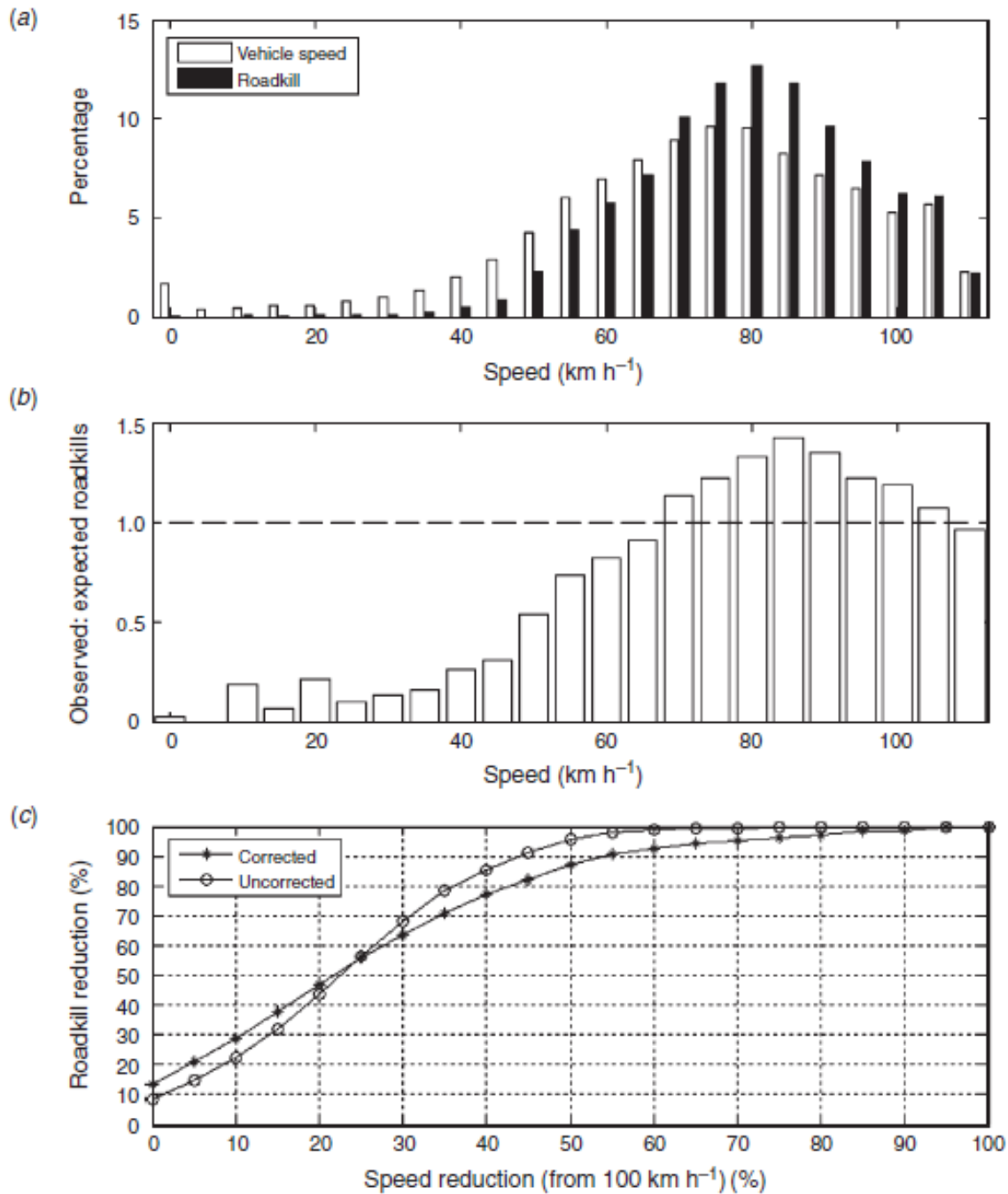
### 7.2.1. Traffic Adaptations for Mitigating Texas Monarch Roadkill

Speed reduction can be effective in reducing wildlife road mortality (Hobday and Minstrell 2008, Glista et al. 2009). In this section, we examine the potential of traffic adaptations in the form of wildlife warning signs and speed reduction signs for mitigating monarch butterfly roadkill in Texas. Mexico has already widely implemented placement of a combination monarch crossing seasonal warning/speed limit signs across northern Mexico (see Chapter 4.2, Fig. 4.8), but they appear to be largely ineffective (Mora Alvarez et al. 2019). However, their effectiveness in Mexico has not been directly studied, and their effectiveness in Texas could be greater depending on differences in sign design, placement, and driver compliance.

The effects of vehicle speed on roadkill incidence has been more studied for vertebrates than for butterflies. Hobday and Minstrell (2008) made field records of vertebrate roadkill in Tasmania, Australia while recording their vehicle speed. They found roadkill was higher than expected along roadway sections where they traveled at speeds above 70 km/hr (43 mph) (Fig. 7.2A-B). They developed a roadkill speed mitigation curve which revealed that a 20% (20 km) reduction in speed from 100 km/hr (62 mph) to 80 km/hr (50 mph) yielded a 50% drop in vertebrate roadkill (Fig. 7.2C). A butterfly roadkill speed mitigation curve has not yet been developed. Field observations by Rao and Girish (2007) indicate that vehicle speeds of 30-40 km/hr (18-25 mph) are "safe" for flying insects, and speeds of 50-60 km/hr (31-37 mph) produce "severe shock/trauma" resulting from vehicle collisions. It is reasonable to assume that they observed at least a 50% drop in butterfly roadkill from a 20 km reduction in speed from 55 to 35 km/hr, which corresponds to a change of 20% reduction in speed from 100 km/hr in the vertebrate roadkill mitigation curve. Consequently, 20% reductions in speed may approximately yield 50% reductions in roadkill for both vertebrates and butterflies. However, the shapes of vertebrate and butterfly roadkill mitigation curves across specific speed reduction percentages may be quite different.

The highly variable nature of ambient wind conditions and aggregate butterfly movements in the field would add much complexity to collecting field data on how vehicle speed and type influence butterfly roadkill incidence. McKenna et al. (2001) observed butterflies being caught in wind vortexes and catapulted over cars traveling at speeds above 88 km/hr (55 mph) in the fall in Illinois. Santhosh and Basavarajappa (2014) observed a greater incidence of butterflies being catapulted over larger vehicles (buses and semitrucks) along a national highway in India compared to lighter vehicles (scooters and cars) with which they more frequently collided. Computational fluid dynamics models (CFDMs) may be able to predict interactions of monarchs with wind currents of different types of vehicles traveling at different speeds (see Appendix B). Wildlife-vehicle collision models (WVCMs) (e.g., Hels and Buchwald 2001, Litvaitis and Tash 2008; Jaarsma et al. 2006) can predict the probability of a monarch colliding with a





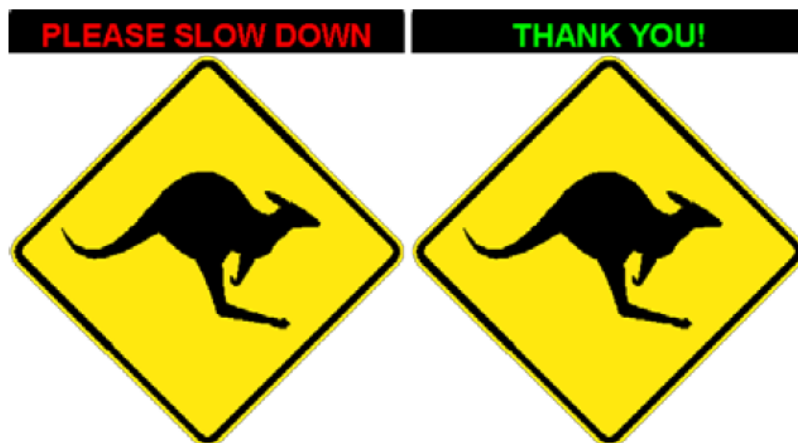
**Figure 7.2. Relationship between survey vehicle speed and vertebrate wildlife roadkill incidence in Tasmania: (A) Frequency percentages of vehicle speeds and associated roadkill incidence; (B) Ratio of observed to expected roadkill at different vehicle speeds (1.0 is expected); and (C) Roadkill speed mitigation curve of rising percent roadkill reduction with rising percent speed reduction below 100 km/hr (62 mph) (Hobday and Minstrell 2008).**

vehicle based upon traffic volume, width of the traffic lane, and monarch flight speed (see Appendix A). Developing monarch WVCs for different vehicle speeds and vehicle class CFDMs for monarch butterflies would be important in the development of a monarch butterfly roadkill speed mitigation curve.

Field testing of speed feedback signs by Santiago-Chaparro et al. (2012) revealed that the most significant driver speed reductions occurred about 366-427m (1,200-1,400 ft) upstream of the sign and 91-152m (300-500 ft) past the sign, giving a total effective range of 335-579m (1,100-1,900 ft). Consequently, an individual wildlife warning/speed feedback sign would probably only be effective over relatively small area of less than 1 km. It is possible that multiple signs spaced at 10-20 km may have greater effectiveness. These signs can be installed in the two known regional monarch fall roadkill hotspot areas. In the monarch Texas Central Funnel, all hotspots have occurred within the Junction/Sheffield/Eagle Pass Roadkill Hotspot Region (Fig. 1.11A). Central Funnel roadway sections with the most roadkill hotspots in order of priority include IH-10 from Sonora to Sheffield (southern San Angelo and eastern Odessa districts), US90 from Sanderson to Comstock (southwestern Odessa and northwestern Laredo districts), US277 from Del Rio to Radar Base (North of Eagle Pass; northern Laredo District), and US90 From Del Rio to Brackettville (northern Laredo District) (Tracy and Coulson 2019, Part III Chapter 2). Texas Coastal Funnel, hotspots have been restricted to the Lavaca Bay Causeway (southwestern Yoakum District) and John F. Kennedy Memorial Causeway (northern Corpus Christi District) within the Point Comfort/Corpus Christi Causeways Monarch roadkill hotspot region (Fig. 1.11B) (Tracy and Coulson 2019).

### 7.2.1.1. Monarch Crossing Seasonal Warning Signs

Bond and Jones (2013) evaluated ten wildlife warning sign designs for effectiveness using public opinion surveys. The highest rated design was a combination of a yellow diamond warning sign showing an animal and a message sign activated through either an animal detection system or speed feedback sign with a message alternating between "Please slow down" and "Thank you" (Fig. 7.3.). They identified the simple design of



**Figure 7.3. Wildlife warning sign with speed feedback sign (Bond and Jones 2013).**

the warning sign and the attention obtained from the speed feedback sign as the critical features for higher ratings. In addition, survey participants indicated that signs with seasonal or time indicators for higher roadkill would be more effective. Based on these findings, we designed an example of a fall activated seasonal monarch crossing wildlife warning sign combined with a speed feedback sign, including speed activated double flashing beacons (Fig. 7.4). The vehicle speed used to activate the sign could be at or below the posted speed limit. Another option is to deploy either separately or additionally a portable



**Figure 7.5. Concept for seasonal monarch crossing warning display on a portable three-line traffic message board.**

three-line traffic message board warning of “Caution Monarchs Slow” (Fig. 7.5).

#### 7.2.1.2. Monarch Crossing Seasonal Speed Advisory Signs

The above discussed combination warning/speed feedback sign can be modified to include an advisory speed feedback sign that could be set to display an advisory speed about 20% lower than the posted regulatory speed, with a goal of reducing roadkill incidence in the neighborhood of 50% (e.g., 65 mph advisory speed in 80 mph regulatory speed zone; Fig. 7.6). The sign could alternate to a “Thank you” message to those heeding the advisory speed. Advisory speeds in Texas are not directly enforceable



**Figure 7.4. Seasonal monarch crossing warning sign concept with speed feedback sign and speed activated double flashing beacons.**

as are regulatory speeds, but they can be used by an enforcement officer as a guide for determining whether to cite a driver for traveling beyond safe speeds (TxDOT 2015).

### 7.3. Indirect Compensatory Mitigation of Monarch Roadkill in Texas



**Figure 7.6. Concept for seasonal monarch crossing advisory speed feedback sign with speed activated double flashing beacons.**

Indirect or compensatory mitigation for monarch roadkill involves offsetting adverse impacts of roadkill through enhancement or restoration of habitat in order to promote monarch population growth (see review in Chapter 6). TxDOT ROWs currently possess significant habitat resources for monarchs in terms of milkweed larval host plants, and milkweed and other adult nectar plants (Part II Chapter 3). In this section, we consider the advantages and disadvantages of five indirect compensatory mitigation types for enhancing and restoring these milkweed/nectar plant habitats either within or beyond TxDOT ROWs that would qualify for helping meeting monarch CCAA commitments. Three of these mitigation strategies are already being implemented by TxDOT, and four represent additional potential strategies (Table 7.2). Three of the strategies fall under monarch habitat enhancements: (1) current TxDOT vegetation management program for roadside brush and invasive grass management; (2) potential roadside marked special management areas; and (3) potential non-roadside habitat enhancement areas. The remaining four strategies fall under monarch habitat restoration: (3) current TxDOT Wildflower Program erosion control seed mixes for planting construction and maintenance sites; (4) current TxDOT monarch waystations; (5) potential roadside planted pollinator habitat areas; and (6) potential non-roadside planted pollinator habitat areas. Primary seasons of monarch

activity in Texas are during the spring and fall (Chapter 1.4), and compensatory mitigation can focus on TxDOT monarch habitats in either the spring, fall, or both, as previously discussed (Fig. 7.1). We focus our discussion below on (1) habitat restoration involving additional modifications of TxDOT pollinator seed mixes and three other potential compensatory mitigation strategies that have not yet been implemented by TxDOT: (2) habitat enhancement through roadside marked special management areas; (3) habitat enhancement through non-roadside habitat enhancement areas; and (4) habitat restoration through roadside planted pollinator habitats. The latter three



**Table 7.2. Current and potential monarch roadkill indirect compensatory mitigation strategies for Texas.<sup>a</sup>**

Compensatory Mitigation Strategy (Categories)	Advantages	Disadvantages
<i>Habitat Enhancement (Chapter 6.1)</i>		
<i>Vegetation and Disturbance Management</i>		
TxDOT Roadside Vegetation Management Program: Roadside Brush and Invasive Grass Management (TxDOT 2018a)	<ul style="list-style-type: none"> <li>• Current TxDOT vegetation management mowing and herbicide spraying programs already help suppress woody brush and invasive grasses</li> <li>• Mowing at prescribed minimum seven-inch height protects fall blooming milkweeds and other nectar plants</li> <li>• Roadsides with strip mowing of only 14-15 feet from shoulder can allow greater persistence of milkweeds and other nectar plants away from the shoulder</li> <li>• Relatively inexpensive compared to other alternatives</li> </ul>	<ul style="list-style-type: none"> <li>• Current TxDOT prescribed first mow in late spring (late June) and second mow in late fall (late Nov-Dec), allows mowing during the summer (Jul-Sep) reducing fall milkweed and other fall nectar plants. Allowed mid fall (Nov/early Dec) mowing can overlap with monarch coastal migration and prevent late fall seeding of fall milkweeds and nectar plants</li> <li>• Mowing can occur outside of prescribed times due to weather delays. This includes early-mid fall (Oct/early Nov) when monarchs are migrating, and February, when nectar plants are growing, esp. in South Texas</li> <li>• Mowing below the prescribed seven inches (e.g., to four inches) sometimes occurs during summer, fall, and early winter, damaging fall and spring blooming milkweeds and other nectar plants</li> <li>• Current TxDOT herbicide spray programs do not have prescribed times, and could impact milkweed and nectar plant growth, such as during the fall migration in Oct/Nov</li> </ul>

**Table 7.2 (Cont.). Current and potential monarch roadkill indirect compensatory mitigation strategies for Texas.<sup>a</sup>**

Compensatory Mitigation Strategy (Categories)	Advantages	Disadvantages
<i>Habitat Enhancement (Chapter 6.1) (Cont.)</i>		
<i>Vegetation and Disturbance Management (Cont.)</i>		
Roadside Marked Special Management Areas (OrDOT 2015; NCDOT 2020a, 2020b)*	<ul style="list-style-type: none"> <li>• Reduces unintended mowing, mowing below seven inches, or spraying of monarch nectar plants</li> <li>• TxDOT Districts visibly demonstrate conservation to public</li> <li>• Can also be employed for protecting rare plants or plantings</li> <li>• Cost savings from reduced mowing regimes and herbicide use in areas</li> </ul>	<ul style="list-style-type: none"> <li>• Initial time and expense in site selection</li> <li>• Requires close coordination within District to limit mowing and spraying activities to optimal times promoting spring and fall monarch/pollinator habitats</li> <li>• Ongoing expense for periodic monitoring and oversight of specialized management practices</li> <li>• Potential reduction in driver visibility and safety from specialized vegetation management would need to be studied and minimized</li> </ul>
Non-Roadside Habitat Enhancement Areas (OrDOT 2015)*	<ul style="list-style-type: none"> <li>• Enhances established monarch habitat in areas away from roadways</li> <li>• Allows for larger tracts of contiguous land (e.g., 20 acres) to be devoted to enhancement for monarchs</li> <li>• Does not interfere with roadway maintenance activities</li> </ul>	<ul style="list-style-type: none"> <li>• Requires purchase of non-ROW lands</li> <li>• Initial time and expense for site selection</li> <li>• Ongoing expense for periodic monitoring and oversight of specialized management practices such as periodic mowing or prescribed burns</li> </ul>

**Table 7.2 (Cont.). Current and potential monarch roadkill indirect compensatory mitigation strategies for Texas.<sup>a</sup>**

Compensatory Mitigation Strategy (Categories)	Advantages	Disadvantages
<i>Habitat Restoration (Chapter 6.2)</i>		
<i>Vegetation Restoration</i>		
TxDOT Wildflower Program and Erosion Control Seed Mixes for Planting Construction and Maintenance Sites (TxDOT 2014a, 2017, 2018b, 2019)	<ul style="list-style-type: none"> <li>• Current TxDOT wildflower program promotes many nectar plants for monarchs and other pollinators (5,000 acres planted in 2017)</li> <li>• Seed mixes periodically modified to include additional monarch-preferred nectar plants</li> <li>• Relatively inexpensive compared to other alternatives</li> </ul>	<ul style="list-style-type: none"> <li>• Regional seed mixes are missing or contain relatively low amounts of the important monarch milkweeds and other spring and fall nectar resources</li> <li>• Seed sources may be unavailable or prohibitively expensive for some regional nectar species important to monarchs, especially green antelopehorns, antelopehorns, and zizotes milkweed</li> </ul>
TxDOT Monarch Waystations (TxDOT 2018b)	<ul style="list-style-type: none"> <li>• Current TxDOT monarch waystations provide milkweeds and nectar plants at safety rest stops</li> <li>• TxDOT Districts visibly demonstrate conservation to public</li> </ul>	<ul style="list-style-type: none"> <li>• Expense for construction, including pavement and shelter, and maintenance limits the number of waystations available</li> </ul>
Roadside Planted Pollinator Habitat Areas (OhDOT 2016)*	<ul style="list-style-type: none"> <li>• Establishes new roadside areas of monarch pollinator habitat</li> <li>• Cost savings from reduced mowing regimes and herbicide use in areas</li> <li>• Improves public perception of TxDOT pollinator health initiatives</li> </ul>	<ul style="list-style-type: none"> <li>• Initial time and expense for site selection, seed bed preparation, and seeding</li> <li>• Seed sources may be unavailable or expensive for some regional milkweeds and nectar species</li> <li>• Ongoing expense for periodic monitoring and oversight of specialized management practices</li> <li>• Potential reduction in driver visibility and safety from plantings would need to be studied and minimized</li> </ul>

**Table 7.2 (Cont.). Current and potential monarch roadkill indirect compensatory mitigation strategies for Texas.<sup>a</sup>**

Compensatory Mitigation Strategy (Categories)	Advantages	Disadvantages
<i>Habitat Restoration (Chapter 6.2) (Cont.)</i>		
<i>Vegetation Restoration</i>		
Non-Roadside Planted Pollinator Habitat Areas (OrDOT 2015)	<ul style="list-style-type: none"> <li>• Establishes new areas of monarch habitat in areas away from roadways</li> <li>• Allows for larger tracts of contiguous land (e.g., 20 acres) to be devoted to restoration for monarchs</li> <li>• Does not interfere with roadway maintenance activities</li> </ul>	<ul style="list-style-type: none"> <li>• Requires purchase of non-ROW lands</li> <li>• Initial time and expense for site selection, seed bed preparation, and seeding</li> <li>• Seed sources may be unavailable or expensive for some regional milkweeds and nectar species</li> <li>• Ongoing expense for periodic monitoring and oversight of specialized management practices</li> </ul>

<sup>a</sup>\*Indicates mitigation strategy for monarchs that is further examined in text.



mitigation strategies represent nationally recognized best management practices for pollinators employed by other state DOTs (AASHTO 2004; USDOT-FHWA 2015, 2016). The strategy of habitat restoration through non-roadside planted pollinator habitats is basically a more expensive combination of the non-roadside habitat enhancement and roadside habitat restoration strategies, and is not discussed further. The lack of correlation between Lepidoptera roadkill and monarch roadside habitat (Part II Chapter 3), reduces the concern for increasing monarch roadkill through implementing compensatory mitigation in the form of either roadside habitat enhancement or restoration.

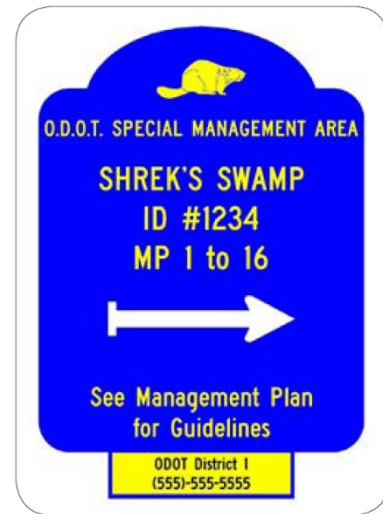
### 7.3.1. Habitat Enhancement for Mitigating Texas Monarch Roadkill

#### 7.3.1.1. Roadside Marked Special Management Areas

Monarch and other pollinator habitat plants of especially high quality occur densely in hotspot locations along TxDOT ROWs, such stands of green antelopehorns milkweed or fall blooming goldenrods (Part II Chapter 3). Preservation and enhancement of this already available valuable roadside monarch habitat is more efficient conservation goal than creation of new habitat (Kasten et al. 2016). Selected stands of valuable monarch pollinator habitat can benefit from specialized management protecting these stands from mowing and dicot herbicide spraying. Special signage would be useful for identifying these valuable monarch pollinator habitats to remind maintenance staff of site-specific management strategies that the TxDOT district prescribes for their protection (c.f.. USDOT-FHWA 2015).



**Figure 7.8. Oregon DOT Special Management Area coded instructions matrix sign (codes for activity to left and season codes across top) with yellow decoder card (AASHTO 2004).**



**Figure 7.7. Oregon DOT Special Management Area marker sign (USDOT-FHWA 2015).**

For example, Oregon DOT (OrDOT; 2015) has established marked Specialized Management Areas (SMAs) along its ROWs in order to maintain threatened and endangered species, rare plants, or cultural sites. Each SMA is marked by special signage that includes a site name, ID number, mileage

marker locations, and reference to a management plan identifying the OrDOT district and phone number (Fig. 7.7) (OrDOT 2015). An SMA management prescription sign includes a coded matrix indicating the timing of different allowed maintenance activities, such as mowing or spraying. The OrDOT maintenance crews are provided with decoder cards for interpretation of the coded SMA management sign (Fig. 7.8). As of 2004, at least 40 SMAs had been established in 15 OrDOT maintenance districts, all with standardized signage providing instructions in order to avoid inappropriate management (AASHTO 2004). The OrDOT SMAs are regularly monitored by the districts which implement the special management practices. The OrDOT SMAs for protected species are managed in agreement with USFWS. The SMAs are restricted to an area outside of the Operational Roadway that is maintained for driver safety, which usually extends to 10 feet beyond the shoulder or four feet beyond the bottom of a roadside ditch. Protected ROW areas that do not need routine maintenance are designated and managed as Resource Protection Areas (RPAs), and they may also be marked by signs. Boundaries of both SMAs and RPAs are maintained in a GIS database (OrDOT 2015).

Wisconsin DOT (WisDOT) also has specially managed ROW areas to protect wild lupine host plants of the federally endangered Karner blue butterfly (*Lycaeides melissa samuelis*) (USDOT-FHWA 2016). In the WisDOT specially managed areas, mowing and brush removal is timed to avoid the growing season, and herbicide spraying is limited to spot treatments for removing invasive plants.

Signage similar to that used for OrDOT SMAs could be adapted for use in protecting hotspots of monarch pollinator habitat along Texas ROWs (Fig. 7.9). Each TxDOT SMA could be identified by TxDOT District and the targeted plant species for protection, such as "Milkweed" or "Goldenrod". TxDOT SMA signs could also provide a unique ID# and indicate location according to the Texas Reference Marker (TRM) system (TxDOT 2005), including the signed highway number and beginning and ending mileage numbers. Similar signage and procedures could be used by TxDOT Districts for establishing and maintaining SMAs for listed plants, with the protected plant species on the sign indicated as "Rare Plants" or "Flowers" in order to preserve the anonymity of listed species locations. Specialized management plans approved by each TxDOT District for the SMA along with GIS location layers and regular



**Fig. 7.9. Concepts for TxDOT pollinator habitat and Waco District Special Management Area sign for ROW milkweed habitat for monarchs.**



**Figure 7.10. Prescribed Dec/Jan mow and no spray sign concept for ROW Special Management Areas.**

late spring before senescence to stimulate fall regrowth in case there are sufficient rains (Baum and Sharber 2012, Baum and Mueller 2015), but this would need to be carefully timed to avoid risk to developing monarch larvae.

North Carolina DOT (NCDOT) has special “Marked Areas” in the ROW for rare, threatened, and endangered plants that employ signs at both ends of the plant population stating “Do Not Mow” (some including dates for the no mow period of April 1- November 15) and sometimes “Do Not Spray” (NCDOT 2020a,b). Colorado DOT (CDOT) maintenance specifications for ROW rare species includes avoiding mowing until late September and eliminating dicot herbicides (monocot herbicides are allowed) (AASHTO 2004). For especially long stretches of NCDOT

assessments from annual or biennial inspections can be kept on file in a TxDOT SMA database by Site ID.

For milkweed and other monarch nectar plants, special management plans could include prescribing all mowing and spraying activities during the non-growing season from December to January. Such a plan would allow for maximum growth and seed production for spring and fall milkweed and nectar species for monarchs. Mandatory Dec/Jan mowing in SMAs would reduce competition of monarch nectar plants from other plants, such as young shrubs and invasive grasses. Management for maximum spring milkweed and nectar plants would contribute more to later season monarch population growth than for fall milkweeds and nectar plants (Fig. 7.1). Some SMAs could be specially managed for fall milkweeds and other monarch-preferred nectar plants, which are apparently less common along roadsides than spring milkweeds and nectar plants (see section 7.3.2.1. below). A strategy for increasing fall milkweeds involves mowing the plants in



**Figure 7.11. Conceptualization of marked TxDOT Special Management Area (SMA) for milkweed with signage, including white tipped wooden stakes to mark protected milkweeds.**



Marked Area roadway, several double-sided “Do Not Mow” signs are sometimes placed to increase the chance a mower will encounter a sign before the entire area is mowed. In addition, NCDOT sometimes places white-tipped wooden stake markers to 2020a,b). Signs with universal “No Mow” and “No Spray” symbols to better demarcate these areas are being considered (NCDOT 2020b). A sign with symbols indicating prescribed Jan/Dec mowing and no spraying might better protect listed species as well as valuable monarch pollinator habitat in Texas ROWs (Figs. 7.10). The prescribed mow/no spray sign could be combined with TxDOT pollinator habitat/SMA signs to provide extra clarity of special management plans for the area (Fig. 7.11). SMAs are limited to the ROW outside of the Operational Roadway area by OrDOT (about 10 ft from shoulder), and some Texas SMA boundaries could be kept at least 14-15 feet from the ROW edge to allow for strip mowing to maintain driver visibility (TxDOT 2018a) (Fig. 7.12-13).



**Figure 7.12. Strip mow sign concept for ROW Special Management Areas.**



**Figure 7.13. Concept for Special Management Area with strip mowing signage (background photo from TxDOT 2018a).**

### 7.3.1.2. Non-Roadside Habitat Enhancement Areas

Non-ROW land with good monarch habitat of milkweeds and preferred nectar plants can be purchased and enhanced as a form of compensatory mitigation. The OrDOT has purchased non-ROW land for habitat enhancement to mitigate loss of ROW habitat for the federally endangered Fender’s blue butterfly (*Icaricia icarioides fenderi*), which only occurs in western Oregon (Fig. 7.14). These mitigation lands are part of the OrDOT Routine Maintenance Habitat Conservation Plan approved by USDI-FWS (OrDOT 2015). For example, OrDOT purchased 20 acres of upland meadow from a private landowner



southwest of Philomath, Oregon as compensatory mitigation for ROW loss of Fender's blue habitat arising from a 10-year bridge building program. The land was chosen for its proximity to other protected Fender's blue habitat patches, between which it serves as a "stepping stone" for connectivity. Fencing was constructed by OrDOT to keep out cattle from the habitat, and plans were made to implement prescribed burns, mowing, and spraying as needed to eliminate weeds and promote growth of the only host plant for Fender's blue, the federally threatened Kincaid's lupine (related to bluebonnets) (Kislingbury 2013).



**Fig. 7.14. Federally endangered Fender's blue butterfly (USDI FWS 2016).**

### 7.3.2. Habitat Restoration for Mitigating Texas Monarch Roadkill

#### 7.3.2.1. TxDOT Wildflower Program and Erosion Control Seed Mix Modifications

Seed sources for new monarch-preferred nectar plants are periodically being developed and added to TxDOT seed mixes (TxDOT 2017, 2018b; Travis Jez, TxDOT personal communication). These seed mixes are used in ROWS disturbed through construction and maintenance (TxDOT 2014a, 2020b). Our fall 2019 and spring 2020 Texas roadside field transects revealed 16 common species of roadside milkweeds and monarch-preferred nectar plants, including four major milkweed species, nine other common spring blooming nectar plants, and three common fall blooming nectar plants (Table 7.3) (Part II Chapters 3-5). These monarch-preferred nectar species appear to be the best adapted to Texas roadside conditions, such as mowing, disturbed soils, and competition with other roadside grasses and forbs. Consequently, roadside monarch habitats could benefit from inclusion of some of these species in TxDOT pollinator seed mixes. Ten of these 16 species are profiled as valuable roadside nectar plants by TxDOT (2020a) (Table 7.3). Several of these species are probably adapted to roadsides in a wider number of TxDOT districts than indicated by our transect records. For example, Texas vervain is also common in the Rio Grande Valley in the Pharr district according to iNaturalist (2020). Seeds of the four milkweed species would be most desirable due to their provision of both larval food and very high value adult nectar for monarchs in the spring and sometimes fall. Seeds of these milkweeds are expensive and difficult to obtain commercially, but TxDOT has recently been obtaining seeds of zizotes milkweed (and also butterflyweed, *A. tuberosa*) for seed mixes (Travis Jez, TxDOT, personal communication). TxDOT already uses five of the nine listed common roadside spring nectar plant species in their regional wildflower or district erosion seed mixes (Table 7.3) (TxDOT 2014a, 2020b), and consideration could be given to increasing the proportion of

**Table 7.3. Most common Texas roadside milkweeds and other monarch preferred nectar plants in fall 2019 and spring 2020 transects and their use in TxDOT seed mixes (listed in order of abundance by seasonal categories).**

Category – Species (* = Profiled in TxDOT 2020a)	Monarch Value Rating <sup>a</sup>	Flowering Period <sup>b</sup>	Observed Roadside Distribution in Major TxDOT Districts <sup>c</sup>	Presence in TxDOT Wildflower Regional Seed List ( <i>WR-No. Regions</i> ) or District Erosion Rural Seed Mix List ( <i>DE- Districts</i> ) <sup>d</sup>	Source for Value Rating
<i>Milkweeds – Spring, sometimes Fall Blooming – Larval Host and Adult Nectar Plants</i>					
Green Antelopehorn ( <i>Asclepias viridis</i> )*	Very High	Apr-May; sometimes Sep	ATL, BMT, BWD, CRP, DAL, FTW, HOU, LFK, PAR, TYL, WFS, YKM	--	USDA NRCS 2018
Antelopehorns ( <i>A. asperula</i> <i>ssp. capricornu</i> )*	Very High	Apr-May; sometimes Sep	ABL, AUS, BWD, DAL, FTW, LRD, SAT, SJT, WAC, YKM	--	USDA NRCS 2018
Zizotes Milkweed ( <i>A. oenotheroides</i> )*	Very High	Apr-Sep; Peak Sep	ABL, AUS, BRY, BWD, CHS, CRP, FTW, HOU, LBB, LRD, PHR, SAT, SJT, WAC, WFS, YKM	--	USDA NRCS 2018
Broadleaf Milkweed ( <i>A. latifolia</i> )	Very High	Jun-Oct; Peak Jun	ABL, LBB, SJT	--	USDA NRCS 2018
<i>Spring Blooming Nectar Plants</i>					
Lance Leaved Coreopsis ( <i>Coreopsis lanceolata</i> )*	High	May-Jul; Peak Jun	ATL, BMT, BRY, HOU, LFK, PAR, TYL	<i>WR-2<sup>e</sup>; DE-ATL, BMT, BRY, HOU, LFK, TYL</i>	Congeners- USDA NRCS 2018
Engelmann Daisy ( <i>Engelmannia peristenia</i> )*	High	Mar-May; Peak Apr	ABL, AUS, BWD, DAL, FTW, SAT, SJT, WAC	<i>DE-ABL, AUS, BWD, DAL, FTW, SJT, WAC, WFS</i>	USDA NRCS 2018
Texas Vervain ( <i>Verbena halei</i> )	High	Mar-May; Peak Apr <sup>f</sup>	ABL, ATL, AUS, BMT, BRY, BWD, CRP, DAL, FTW, HOU, LFK, LRD, SAT, SJT, TYL, WAC, YKM	--	USDA NRCS 2018
Black Eyed Susan ( <i>Rudbeckia hirta</i> )*	High	May-Sep; Peak Jul	YKM	<i>WR-4</i>	USDA NRCS 2018

**Table 7.3. Most common Texas roadside milkweeds and other monarch preferred nectar plants in fall 2019 and spring 2020 transects and their use in TxDOT seed mixes (listed in order of abundance by seasonal categories).**

Category – Species (* = Profiled in TxDOT 2020a)	Monarch Value Rating <sup>a</sup>	Flowering Period <sup>b</sup>	Observed Roadside Distribution in Major TxDOT Districts <sup>c</sup>	Presence in TxDOT Wildflower Regional Seed List ( <i>WR-No. Regions</i> ) or District Erosion Rural Seed Mix List ( <i>DE- Districts</i> ) <sup>d</sup>	Source for Value Rating
<i>Spring Blooming Nectar Plants (cont.)</i>					
Climbing Milkweed Vine ( <i>Funastrum cynanchoides</i> ) <sup>9</sup>	High	Mar-May; Aug- Oct	CRP, BRY, HOU, LKF, PHR, TYL, YKM	--	USDA NRCS 2018
Lemon Beebalm ( <i>Monarda citriodora</i> )*	High	Apr-Jun; Peak May	AUS, BRY, DAL, FTW, HOU, SAT, WAC, YKM	WR-7	USDA NRCS 2018
Texas Thistle ( <i>Cirsium texanum</i> )*	High	Mar-Jun; Peak Apr	ABL, AUS, BWD, CRP, DAL, FTW, PHR, SAT, SJT, YKM, WAC, WFS	--	Congeners- Ajilvgsi 2013
Bristle Thistle ( <i>Cirsium horridulum</i> )	High	Mar-Apr	ATL, BMT, BRY, HOU, LFK, YKM	--	Congeners- Ajilvgsi 2013
Prairie Verbena ( <i>Glandularia bipinnatifida</i> )*	High	Mar-Apr	AUS, BWD, LRD, SAT, YKM	WR-8	USDA NRCS 2018
<i>Summer Blooming Nectar Plants</i>					
Eastern Purple Coneflower ( <i>Echinacea purpurea</i> )*	Very High	Jun-Sep; Peak July	-- <sup>h</sup>	WR-3	USDA NRCS 2018
<i>Fall Blooming Nectar Plants</i>					
Northern Seaside Goldenrod ( <i>Solidago sempevirens</i> )	High	Aug-Nov; Peak Sep-Oct	BMT, CRP, HOU, YKM	--	Congeners- Ajilvgsi 2013, USDA NRCS 2018
White Heath Aster ( <i>Symphotrichum ericoides</i> )	High	Aug-Oct; Peak Sep	ABL, AUS, BWD, FTW, LBB, WFS <sup>i</sup>	--	USDA NRCS 2018
Gray Golden-aster ( <i>Heterotheca canescens</i> )	Medium	Jun-Sep	ABL, BWD, CHS, LBB, ODA, WAC	--	BugGuide 2020; <i>H. oregona</i> : Klamath-

Siskiyou Seeds  
2015

<sup>a</sup>Ratings sometimes derived from observations of monarchs nectaring on congeners as noted in Source for Value Rating column. Medium value if no confirmed reports of monarch nectaring for Texas congeners.

<sup>b</sup>From iNaturalist (2021) phenology.

<sup>c</sup>Includes TxDOT districts with records of species on roadsides and adjacent intervening districts.

<sup>d</sup>TxDOT (2014a, 2020b)

<sup>e</sup>Plains *Coreopsis* (*C. tinctoria*) also in *WR-11*.

<sup>f</sup>Unusually still widely in bloom during Oct 2019 roadside observations.

<sup>g</sup>Also larval host plant.

<sup>h</sup>Probably summer bloomer on roadways in AUS, DAL, HOU, FTW, SAT, WAC districts.

<sup>i</sup>Probably also widespread on roadways in DAL, SAT and HOU districts.



these species in current seed mixes. Seeds also appear to be difficult to obtain for the four other common roadside spring nectar plants: Texas vervain, climbing milkweed vine, Texas thistle, and bristle thistle (Table 7.3). Only three species of nectar plants were common in the fall along Texas roadsides, northern seaside goldenrod, white heath aster (Fig. 7.15), and gray golden-aster (Table 7.3). Again, seeds of most of these species are probably not commercially available or are expensive. A seed source was found for white heath aster (Prairie Moon Nursery). White heath aster cut back from lawn mowing can still produce abundant low growing blooms that are highly attractive to monarchs in the fall (James McDermott, lepidopterist collection curator, Texas A&M University, personal communication).



**Figure 7.15. Monarch nectaring on white heath aster, 6 November, 2019, College Station, TX.**

Six other monarch preferred nectar plants of Texas (Chapter 6.1), which were not as common along our roadside transects, could also be considered for inclusion in TxDOT seed mixes, such as the very high value blue mistflower, cowpen daisy, Maximillian sunflower, and dotted blazing star, and high value tall goldenrod and frostweed (Table 6.1). Four of these six preferred monarch nectar species are profiled as valuable roadside nectar plants by TxDOT (2020a), including blue mistflower, Maximillian sunflower, dotted blazing star, and tall goldenrod. Ten additional valuable monarch roadside nectar plants (nine of High value and one Very High) are profiled by TxDOT (2020a), including butterflyweed (*Asclepias tuberosa*), swamp milkweed (*A. incarnata*, Very High value), Texas milkweed (*A. texana*), compass plant (*Silphium laciniatum*), roughstem rosinweed (*Silphium radula*), drummond phox (*Phlox drummondii*), eryngo (*Eryngium leavenworthii*), ironweed (*Vernonia baldwinii*), mealy blue sage (*Salvinia farinacea*), orange zexmenia (*Wedelia hispida*) (USDA NRCS 2018; *P. drummondii* and *S. farinacea* are congeners of high value species), and clammyweed (*Polanisa dodecandra*) (Matador Wildlife Management Area 2018). Two of these monarch-preferred species are also now being incorporated into TxDOT seed mixes: clammyweed (ssp. *riograndensis*) and orange zexmenia (TxDOT 2017). Two paintbrush species (*Castilleja*) are also profiled by TxDOT (2020a), one of which, downy paintbrush (*C. indivisa*), is listed as a high value monarch nectar plant by USDA (2018) and included in TxDOT district erosion control and wildflower seed mixes (TxDOT 2014a, 2020b). We follow Alder (2000, 2003) in not regarding paintbrushes as preferred nectar sources for butterflies (Chapter 6.1).

Weighting seed mixes towards spring blooming species benefiting monarchs, especially milkweeds that provide larval food, would probably have a greater effect on increasing annual monarch population growth (Fig. 7.1), but including some fall blooming species may help fall migrant monarchs, especially in view of the fewer nectar resources in the fall along Texas roadways.

Iowa DOT has participated with a variety of partners (e.g., USDA NRCS Elsberry Plant Materials Center, Iowa Crop Improvement Association, University of Northern Iowa, and independent seed producers) in the Iowa Natural Selections program which serves as a model for developing high-quality, regionally adapted, and genetically diverse seed sources for prairie restoration (USDOT-FHWA 2015). The USDA NRCS has three Plant Materials Centers in Texas (USDA NRCS 2020) and universities in Texas may be willing to partner with USDA NRCS and TxDOT to obtain funding to begin a similar Natural Selections program for establishing regional prairie restoration seed sources that include Texas milkweeds and other monarch-preferred nectar plants. Potential startup funding sources for beginning a Texas Natural Selections program include the Monarch Butterfly Conservation Fund, a partnership between USDI FWS and the National Fish and Wildlife Foundation (NFWF) that issues a yearly call for proposals (NFWF 2020), and is already involved in collecting and propagating seeds for milkweed and other nectar plants (USDI FWS 2017b). Establishing regional seed sources for additional monarch-preferred nectar plants, especially the milkweeds and other roadside adapted species, is important for continued additions to TxDOT seed mixes and potential mitigation using planted pollinator areas discussed below.

### **7.3.2.2. Roadside Planted Pollinator Habitat Areas**

Establishment of new monarch roadside pollinator habitat areas with milkweeds and other monarch-preferred nectar plants can be a highly visible way for TxDOT to demonstrate continued commitment to monarch population recovery, especially when made part of a roadside marked special management area for continued maintenance and visibility (see Chapter 7.3.1.1). This compensatory mitigation strategy is much less expensive than establishment of formal monarch waystations at rest stops, with associated paving and shelters (Fig. 6.13). The main expenses for monarch pollinator habitat areas will involve a survey of TxDOT ROWs for site selection for suitable potential restoration areas which will take into account coarse scale suitability to the various regionally adapted monarch nectar plant species based upon climate, topography, and soils. Finer scale assessments will also be important for appropriate topography, soil texture and depth, existing vegetation, and adjacent land use, such as avoiding potential overspray from agricultural crops. As discussed above, weighting these plantings towards milkweeds and other spring blooming monarch-preferred nectar species would best support annual monarch population growth.

Ohio DOT (2016) has developed detailed best management practices for the steps involved in site selection, plant selection, site preparation, planting, short-term maintenance during establishment, long-term maintenance, and evaluating effectiveness for roadside pollinator habitat areas (see also Hopwood et al. 2015, USDOT-FHWA 2015). These steps are also involved in establishing monarch waystations. Recommended long-term maintenance includes reducing mowing in non-critical drive visibility areas to once per year or every other year outside of the growing season and controlling invasive weeds with selective herbicide treatments. Marking pollinator habitat areas with signage can increase visibility and help insure proper management practices (Fig. 7.16). Establishment of a marked SMA as described above (Chapter 7.3.1.1) would be a prudent protection of the heavy investment of developing monarch pollinator habitat areas.



**Figure 7.16. Ohio DOT roadside planted pollinator habitat area signage (OhDOT 2015, 2016).**

## 7.4. Conclusions

Viable options are examined for both direct and compensatory mitigation of monarch roadkill in Texas. The most feasible direct mitigation strategy for monarch roadkill involves traffic adaptations within monarch roadkill hotspots with the addition of seasonal caution and feedback signs to reduce speeds through either generic “slow” messages or advisory speed limits. This type of direct mitigation can potentially substantially reduce monarch roadkill by as much as 50% if vehicle speed can be reduced by around 20%. The uncertainty of hotspot locations from year to year would require signage in multiple hotspot locations. TxDOT is already involved in a number of compensatory mitigation strategies for both monarch habitat enhancement and restoration, making compensatory mitigation a more cost-effective approach than direct mitigation. The most cost-effective addition to current compensatory mitigation strategies involves recommendations on addition of specific monarch-preferred plants to TxDOT pollinator seed mixes. The next most cost-effective additional compensatory mitigation strategy involves habitat enhancement of existing roadside milkweed and

monarch nectar plant hotspots through establishment of roadside marked special management areas. Compensatory mitigation focusing on increasing spring first and second generation monarch reproduction on milkweeds should have the most potential to increase the annual monarch population.

The monarch CCAA encourages, consistent, statewide management of monarchs, providing a semi-regulatory approach to reversing the decline of the eastern population. However, the CCAA is primarily designed to deal with habitat management. Though it provides assurances that will help TxDOT manage rights-of-way, if stricter regulation is imposed, it does not directly address future regulatory issues concerning new road infrastructure, or roadkill. In the case of monarch listing, further tools and research can assist TxDOT in a) identifying proper areas for establishment of monarch marked SMAs, b) assessing effects of vehicle speed on roadkill mortality in case direct roadkill mitigation is additionally planned, and c) developing monarch population models capable of assessing the relative benefit to monarch population recovery from various mitigation actions (see Appendix C). The development of marked SMAs for roadside monarch habitat enhancement may represent the most efficient means for TxDOT to demonstrate additional compensatory mitigation of roadway activities that may be required by USDI-FWS in the event of monarch listing in order to avoid destruction or adverse modification of monarch critical habitats.



## CHAPTER 8. DESIGNS FOR IMPLEMENTATION OF DIRECT MONARCH ROADKILL MITIGATION THROUGH SEASONAL MONARCH FLIGHT DIVERTERS SPECIALIZED MANAGEMENT AREAS ON TEXAS ROADWAYS

### 8.1. Introduction

We previously reviewed five specific potential direct mitigation strategies for monarch roadkill, including (1) seasonal flight diverters, (2) wildlife overpasses, (3) seasonal warning speed feedback signs, (4) seasonal advisory speed feedback signs, and (4) traffic calming (Chapter 7.2). Now, we select the single direct mitigation strategy that would probably have the highest efficacy for reducing monarch roadkill for potential implementation on Texas roadways: Seasonal monarch flight diverters that induce migrating monarchs to fly above the traffic, as has been successfully implemented for migratory purple crow butterflies in Taiwan (Chapter 2.1)

This direct mitigation strategy would be seasonally implemented at monarch protection Specialized Management Areas (SMAs) identified as perennial monarch roadkill hotspots. The SMAs would be identified with public signage for monarch protection and non-public signage for TxDOT maintenance personnel. The option of investigating the efficacy of monarch roadkill reduction through placement of monarch crossing signs with advisory speed reduction is explored in Appendix D.

The primary objective of monarch seasonal flight diverters is to reduce on-site monarch roadkill by as much as 80-90% during the fall migration through diverting monarch flight over the top of vehicular traffic (see Chapter 2.2). This chapter identifies specific TxDOT roadside locations for trial implementation of monarch roadkill direct mitigation, develops potential designs for signage and roadside temporary flight diverters, outlines installation and de-installation periods and required regulatory approvals, and develops protocols for evaluating roadkill reduction.

### 8.2. Texas Roadside Direct Mitigation Locations

Perennial monarch roadkill hotspots were associated with two primary geographic regions in Texas: (1) Central Funnel draws in arid areas along IH-10; and (2) Coastal Funnel causeways (Part III Chapter 3). From these two regions, the three largest roadkill hotspots of the Central Funnel and the three largest roadkill hotspots of the Coastal Funnel were identified as potential SMA sites for monarch seasonal mesh flight diverters: (1) Howard Draw, (2) Eureka Draw, and (3) Granger Draw in the Central Funnel; and (4) Lavaca Bay Causeway, (5) Lyndon B. Johnson Causeway, and (6) John F. Kennedy Causeway in the Coastal Funnel (Table 8.1, Fig. 8.1).

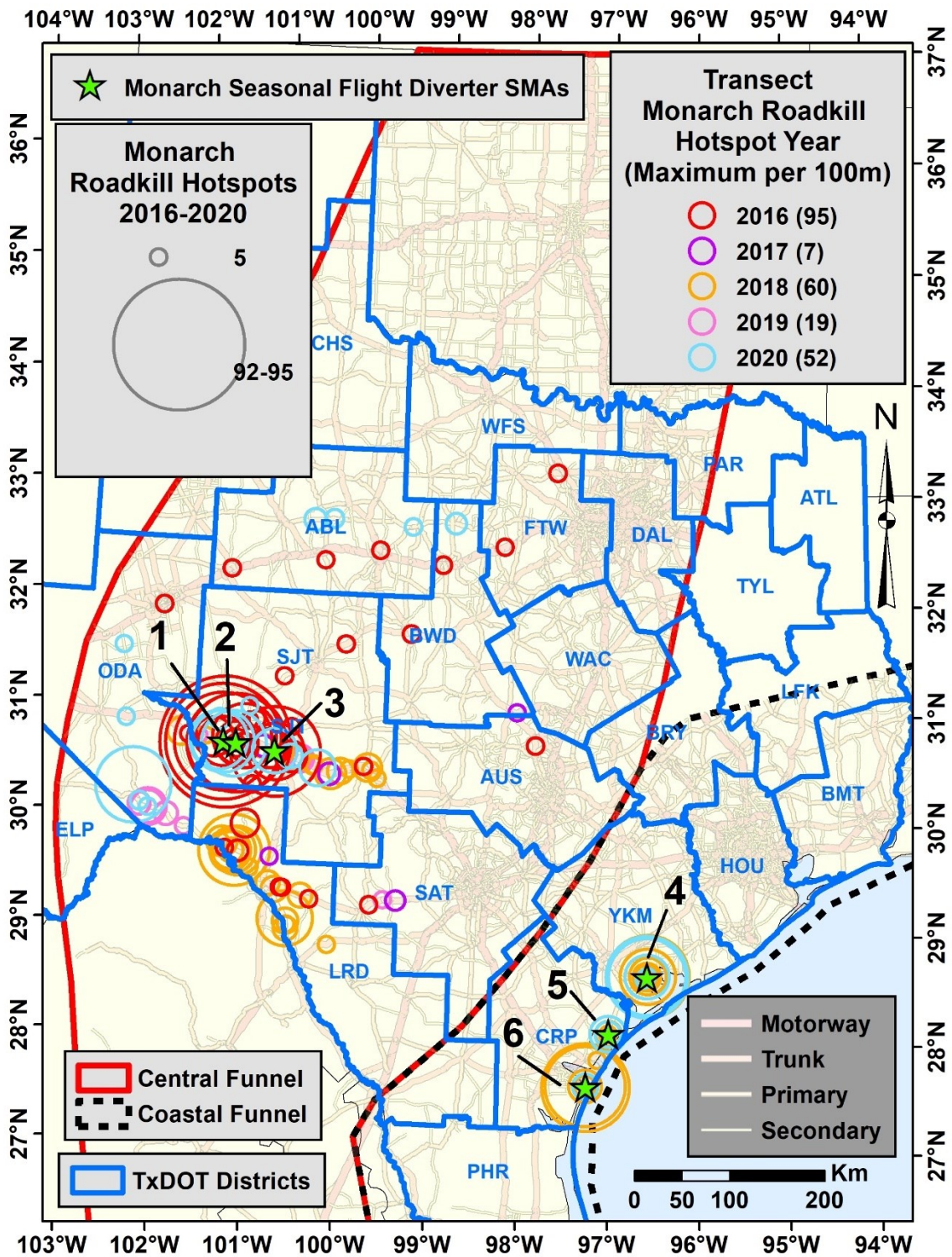
**Table 8.1. Potential monarch protection (MP) Specialized Management Area (SMA) locations and period of operation within wide right-of-ways (ROW) or a bridge support.**

Region/SMA#/Location (TxDOT District)	Geocoordinates <sup>a</sup>		Ranges of Fall Monarch Roadkill per 100 m Transects (High Roadkill Years) <sup>b</sup>	ROW/Shoulder Widths (ft)		
	Latitude	Longitude		ROW Width	Shoulder	ROW Available <sup>c</sup>
<b>Central Funnel – 11-25 October</b> <i>Two week Period for Roadside Presence of Supports Poles, Mesh and Signage</i>						
#MP01 – Howard Draw on IH-10W, 18 mi West Ozona (San Angelo District)	30.69278686	-101.4463	31-136 (2016); 40 (2020)	25	11	6
#MP02 - Eureka Draw on IH-10W, 6 mi West Ozona (San Angelo District)	30.68214485	-101.3065	21-109 (2016)	24	12	6
#MP03 – Granger Draw on IH-10W, 13 mi West Sonora (San Angelo District)	30.62968407	-100.8592	27 (2020)	24	11	5
<b>Coastal Funnel– 25 October to 8 November</b> <i>Two week Period for Roadside Presence of Supports Poles, Mesh and Signage</i>						
#MP04 – Lavaca Bay Causeway on TX-35E West of Point Comfort (Yoakum District)	28.66062182	-96.58321	5-64 (2018); 9-52 (2020)	93	34	93
#MP05 – Lyndon B Johnson Causeway on TX-35E West of Lamar (Corpus Christi District)	28.136976	-97.007949	12 (2018); 13-20 (2020)	31	11	12
#MP06 – John F. Kennedy Causeway (bridge support) on TX-358N South of Corpus Christi (Corpus Christi District)	27.64943595	-97.25297	18-97 (2018); 14 (2020)	0	13	0

<sup>a</sup>Location is beginning of first temporary flight diverter net. See Figs. 8.1, 8.7, and E.1-E.5 for mapped locations.

<sup>b</sup>See Figs. 8.7 and E.1-E.5.

<sup>c</sup>Available ROW calculated by taking the width of a 30 ft clear zone with one shoulder and subtracting the shoulder width from the clear zone, with the remainder subtracted from the total ROW width. At least 5 ft width available ROW desired for flight diverter Specialized Management Area, except for location #MP05 attached to a bridge support.



**Figure 8.1. Potential locations for monarch seasonal flight diverter Specialized Management Areas (SMAs), including three locations on IH-10W in the Central Funnel: (1) Howard Draw, (2) Eureka Draw, and (3) Granger Draw; and two locations in the Coastal Funnel: (4) Lavaca Bay Causeway on TX-35E, (5) LBJ Causeway on Tx-35E, and (6) J.F. Kennedy Causeway on TX-358N (see Table 8.1 and Figs 8.7, E.1-E.5 for detailed locations).**

### 8.3. Overall Design

The general design concept for the pilot monarch seasonal flight diverters includes three 157.5 ft sections of ten 15.75 ft (nominal 16 ft) tarp panels flight diverters at 12 ft height with 157.5 ft gaps for assessing efficacy (see Chapter 8.5 below) at each SMA (Figs. 8.2-8.5). The effective height for land-based installations would be 13.33 ft (#MP02-04), with a 1.33 ft gap at the base to allow small animals to pass under the tarp without damage. The effective height for over-water bridge installation (#MP05) would be 13 ft 9.6" since the flight diverter frame is attached to the mid-height section of the concrete railing (see below).

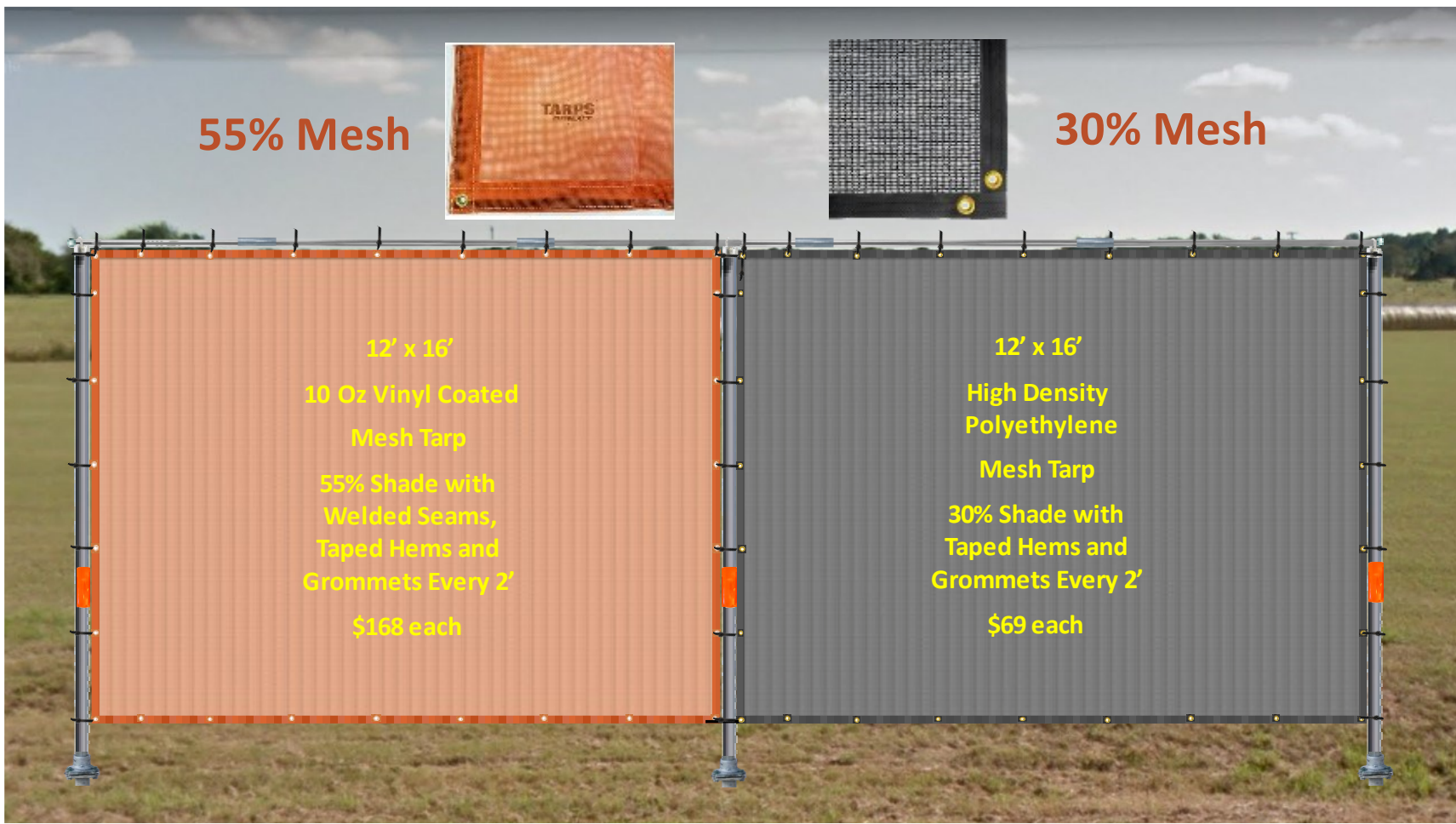
The land-based flight diverter installations are placed outside of the clear zone allowing the safe exit of errant vehicles from the roadway, which is at least 30 ft from the edge of the traffic lane for major highways (TxDOT 2018c) (Figs. 8.6-8.7, E.1-E.4). The over-water flight diverter installation is mounted from the bridge rail (Figs. 8.8, E.5) following TxDOT specifications for bridge rail mounted signs (see below, TxDOT 2014b).

### 8.4 Design Details, Installation, and Approvals

Materials for the frame of the land-based installations consist of 13 ft height signpost supports with break-away slip base anchors (TxDOT 2008), with a fence post top rail connecting the signposts (Fig 8.9). The 6.5 ft top rail sections are attached by connector sleeves to allow easy breakage in a vehicle collision. The diversion net consists of nominal 12 x 16 ft panels (actual size about 11.75 x 15.75 ft) of 10oz vinyl mesh coated tarp rated for either 30% or 55% shade (to be evaluated), welded seams, and taped hems with grommets every two feet. The welded seams and taped hems are important for withstanding heavy winds at installation sites in west Texas or along the coast. The lowest shade percentage available, 30% mesh tarp, should reduce wind drag over the 55% shade tarp, but the 55% shade tarp may be more tear resistant. Heavy duty stainless steel cable ties would be used to secure the tarp through grommets to the signpost supports and top rail (Fig. 8.9). The over-water installation uses signage mounting materials for bridge railing (TxDOT 2014b), combined with added top rails used in the land-based installation (Fig. 8.10).

A TxDOT monarch protection sign would be placed 100 ft up road from the first flight diversion net at each site to publicly identify their monarch butterfly conservation purpose (Figs. 8.4, 8.6-8.8, 8.11A, 8.12A). A non-public TxDOT Specialized Management Area sign would be placed at the first diversion net to signify management objectives and managing office contact information for TxDOT personnel (Figs. 8.3-8.8, 8.11B, 8.12B). Both signs are patterned after TxDOT Special Route Markers for Texas Travel Trails (Texas Heritage Trails Program), such as the Texas Hill Country Trail sign (D71-HC) (TxDOT 2014c) (Fig. 8.11C). All land-based SMA signage would be installed according to





**Figure 8.2. Prototype for testing durability of two types of mesh shade tarp (orange 55% versus black 30% shade) in land-based installation of 15.75 ft (nominal 16 ft) panels of 12 ft height flight diversion tarp at off road evaluation site.**



Figure 8.3. Design concept for land-based installation of three 157.5 ft sections of 12 ft height flight diversion mesh tarp at Howard Draw Specialized Management Area #MP01.



Figure 8.4. Flight diversion mesh tarp with public TxDOT Monarch Protection signage at Howard Draw Specialized Management Area #MP01.



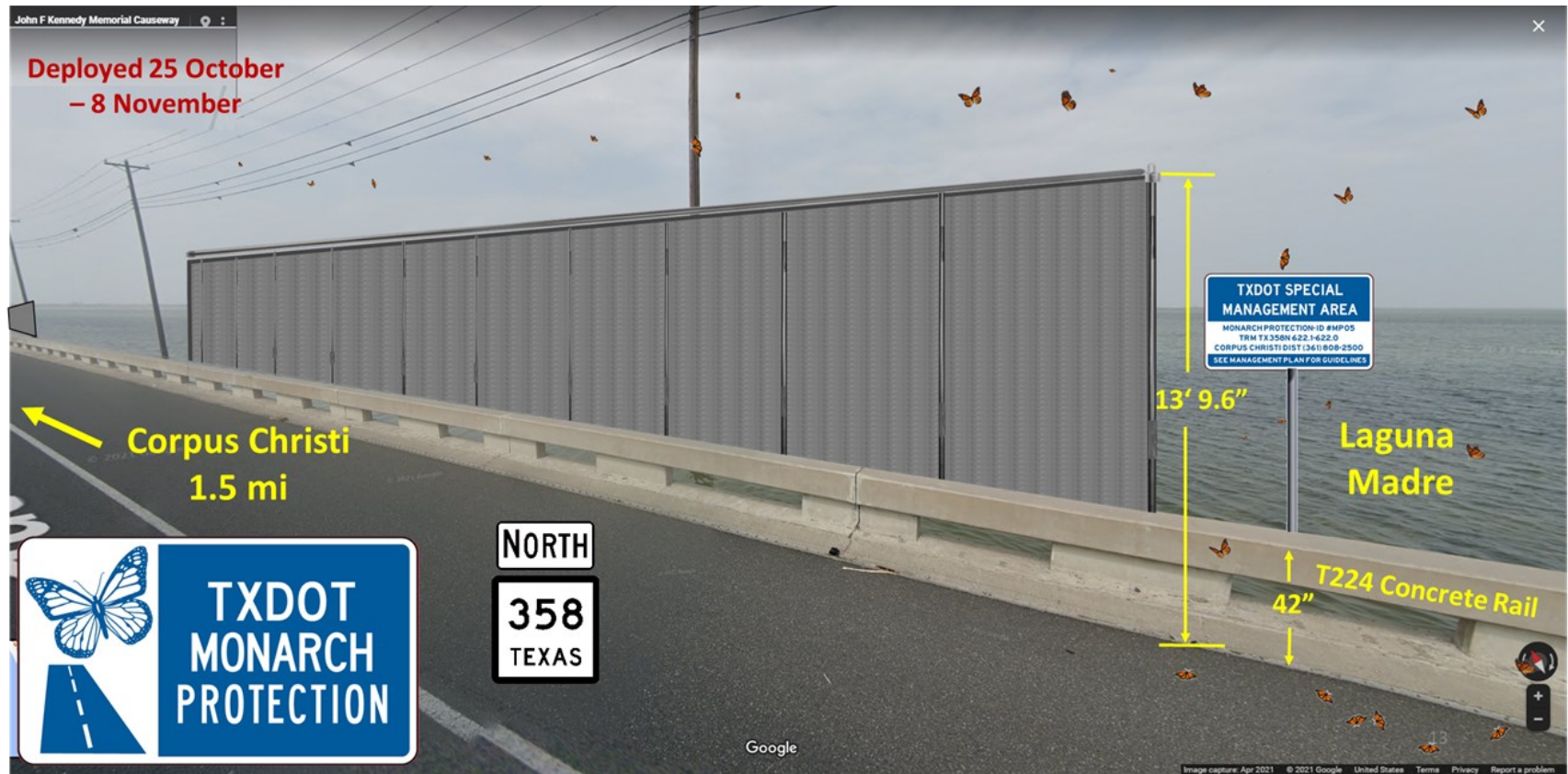


Figure 8.5. Design concept for over-water-based installation of 157.5 ft sections of 12 ft height flight diversion netting tarp at John F. Kennedy Causeway Specialized Management Area #MP05.



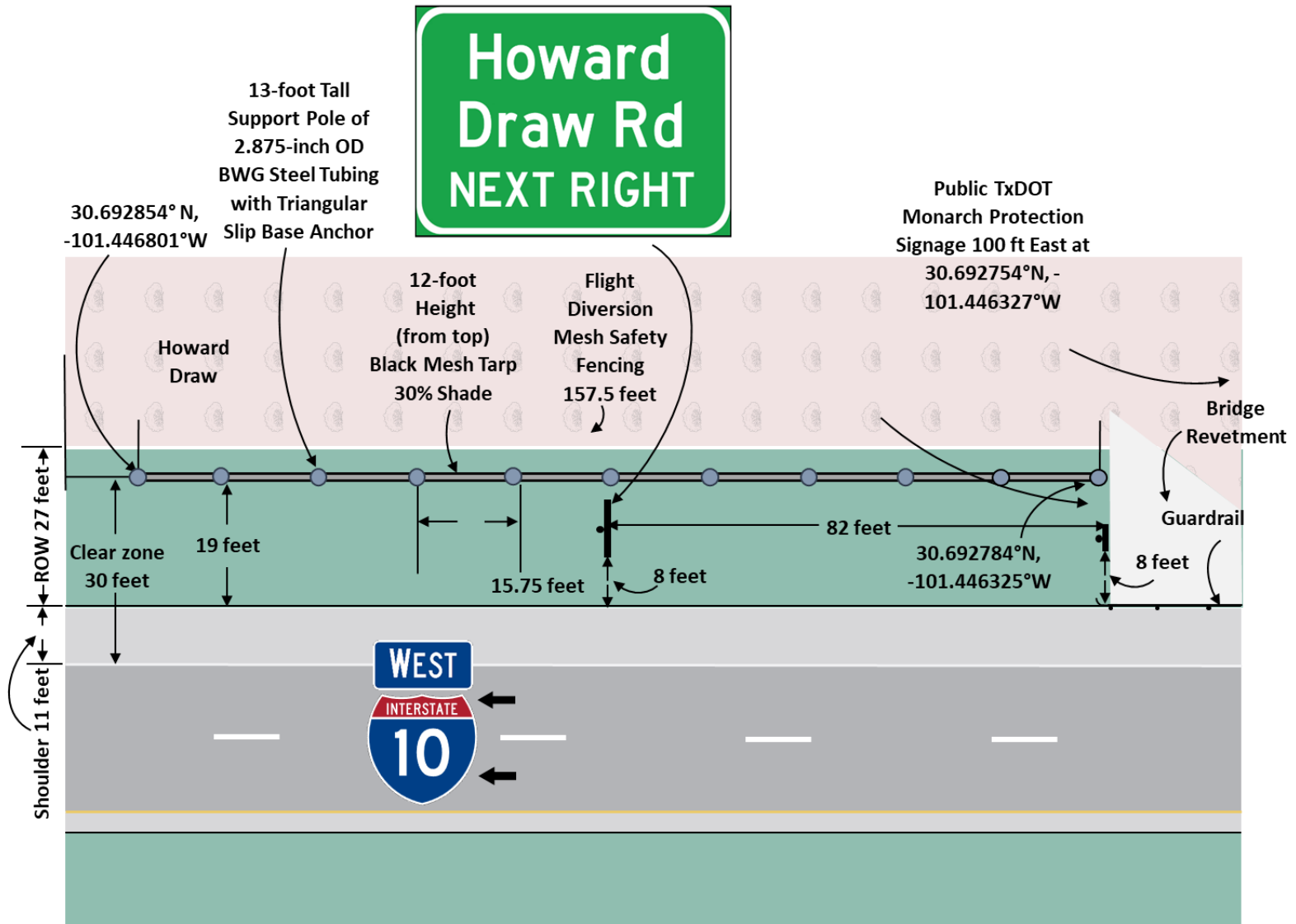


Figure 8.6. Design concept for land-based installation of 157.5 ft sections of 12 ft height flight diversion mesh tarp at Howard Draw Specialized Management Area #MP01.

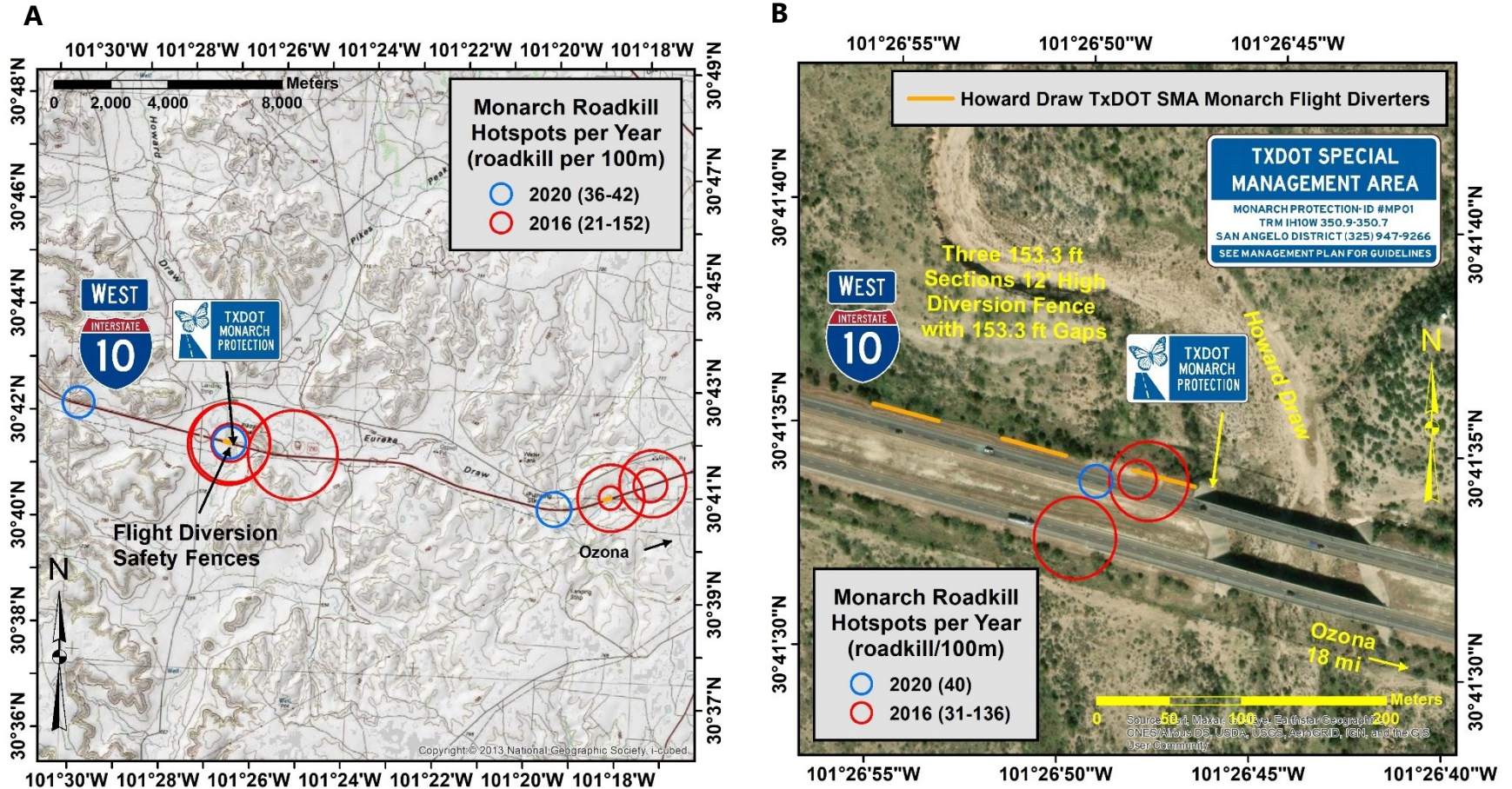


Figure 8.7. Small scale (A) and large scale (B) maps for locations of TxDOT monarch protection signage and 157.5 ft sections of 12 ft height flight diversion tarp at Howard Draw Specialized Management Area (SMA) #MP01 (see Figs. E.1-E.5 for location maps of SMAs #MP02-06).

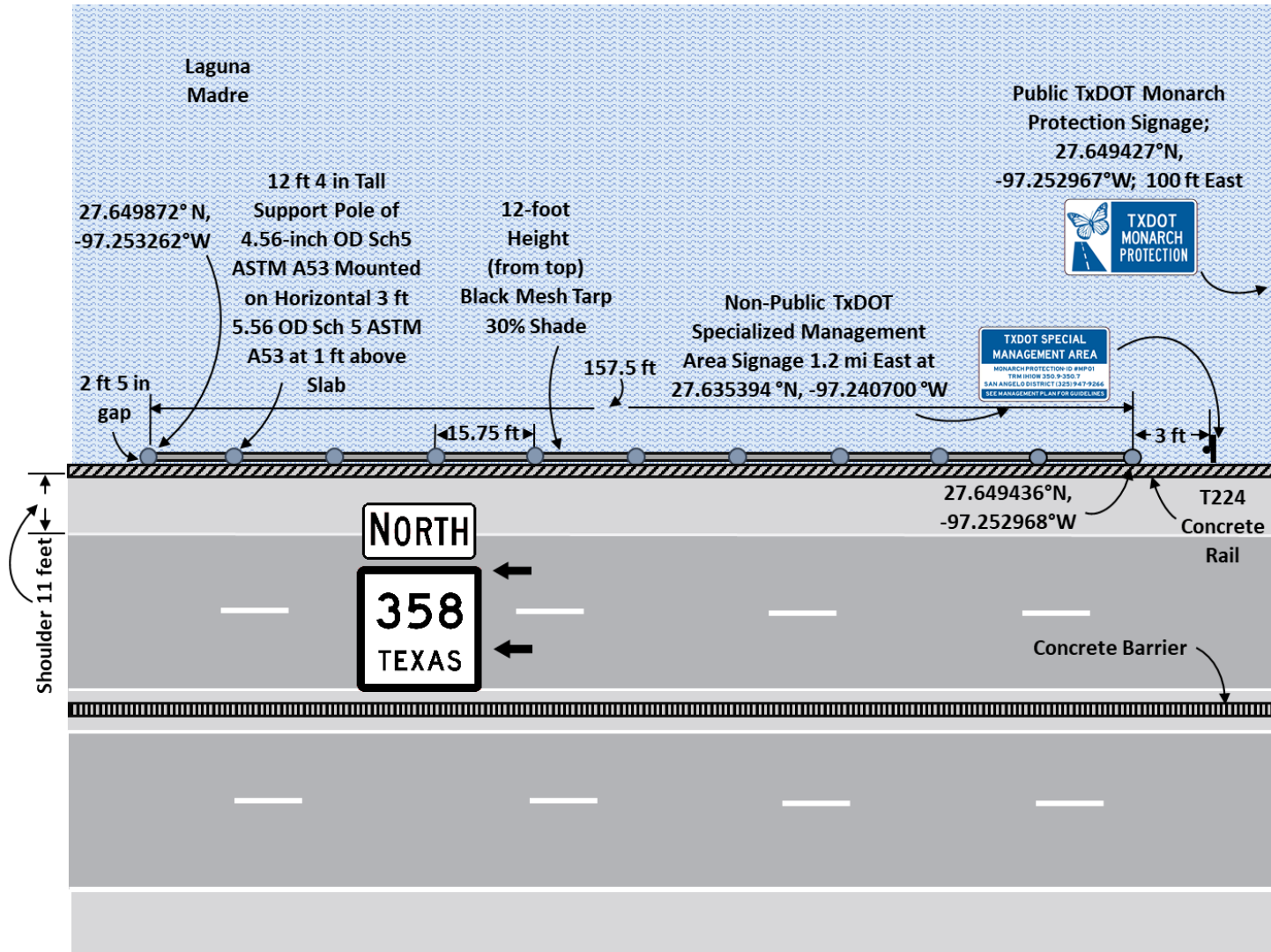


Figure 8.8. Design concept for over-water installation of 157.5 ft sections of 12 ft height flight diversion mesh tarp at the John F. Kennedy Causeway Specialized Management Area #MP06.



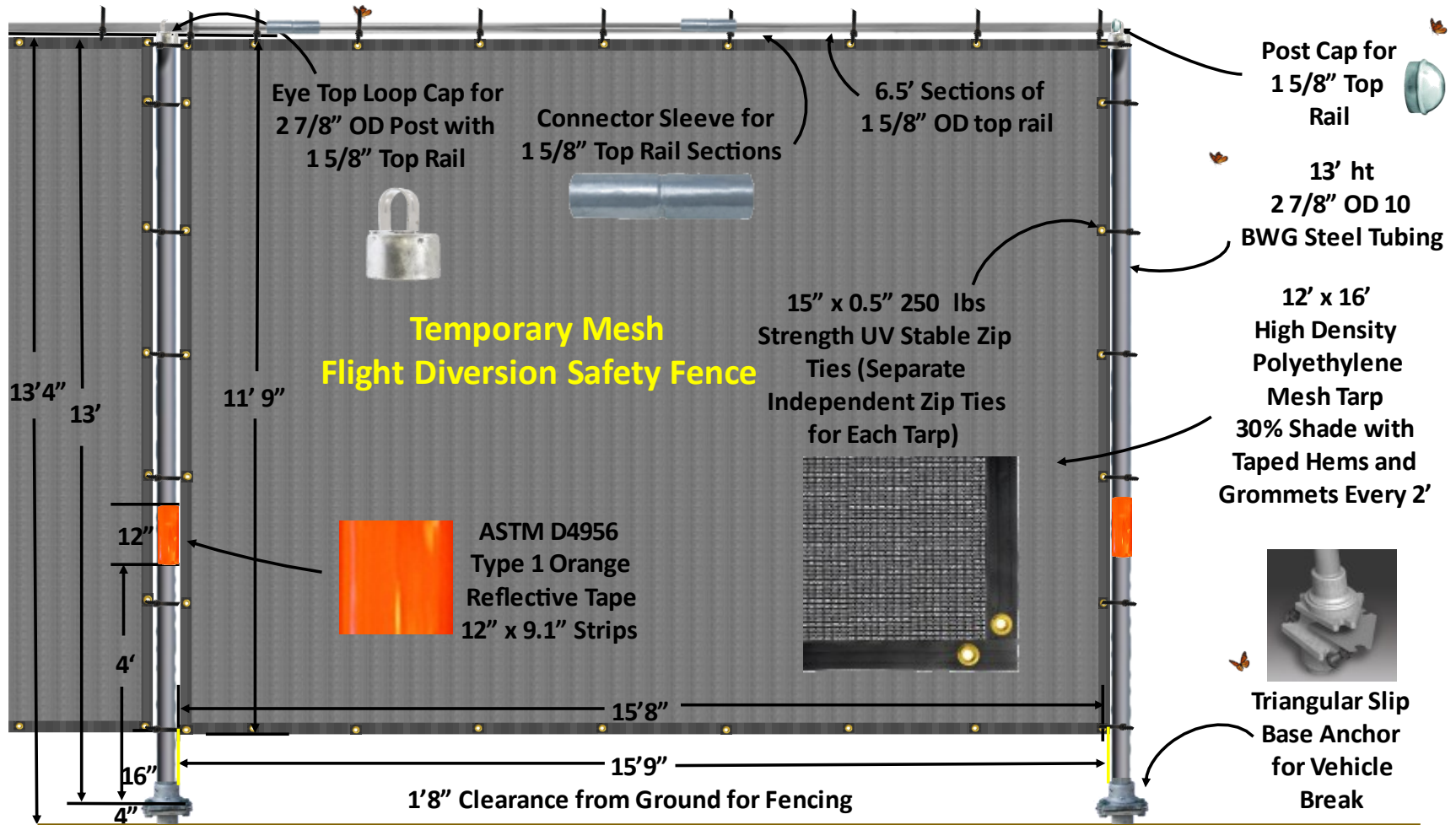


Figure 8.9. Design and materials for one of ten 15.75 ft panels per section of 12 ft height flight diversion mesh tarp at Specialized Management Areas #MP01-05 (see Fig. 8.10 for modifications regarding SMA #MP06).



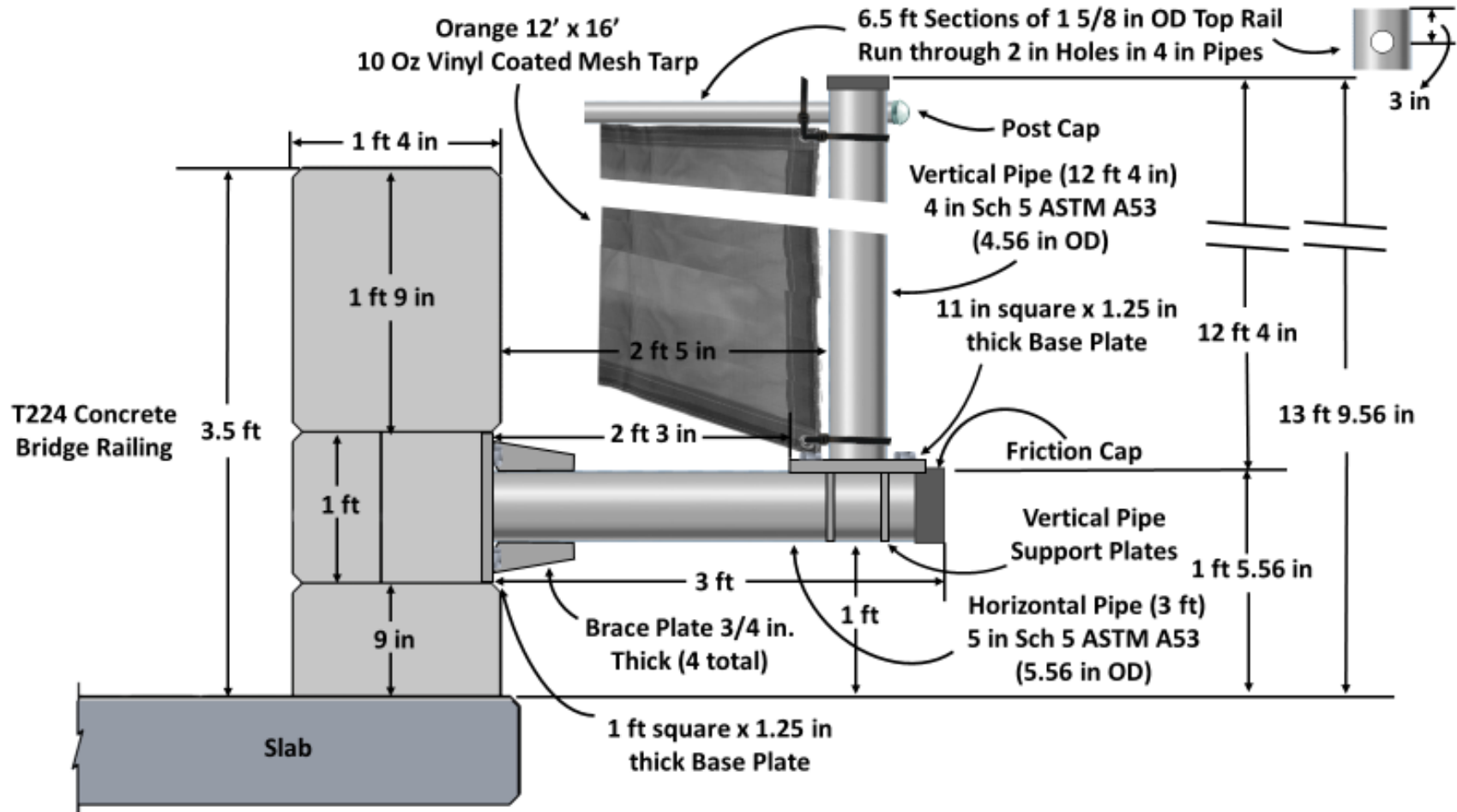
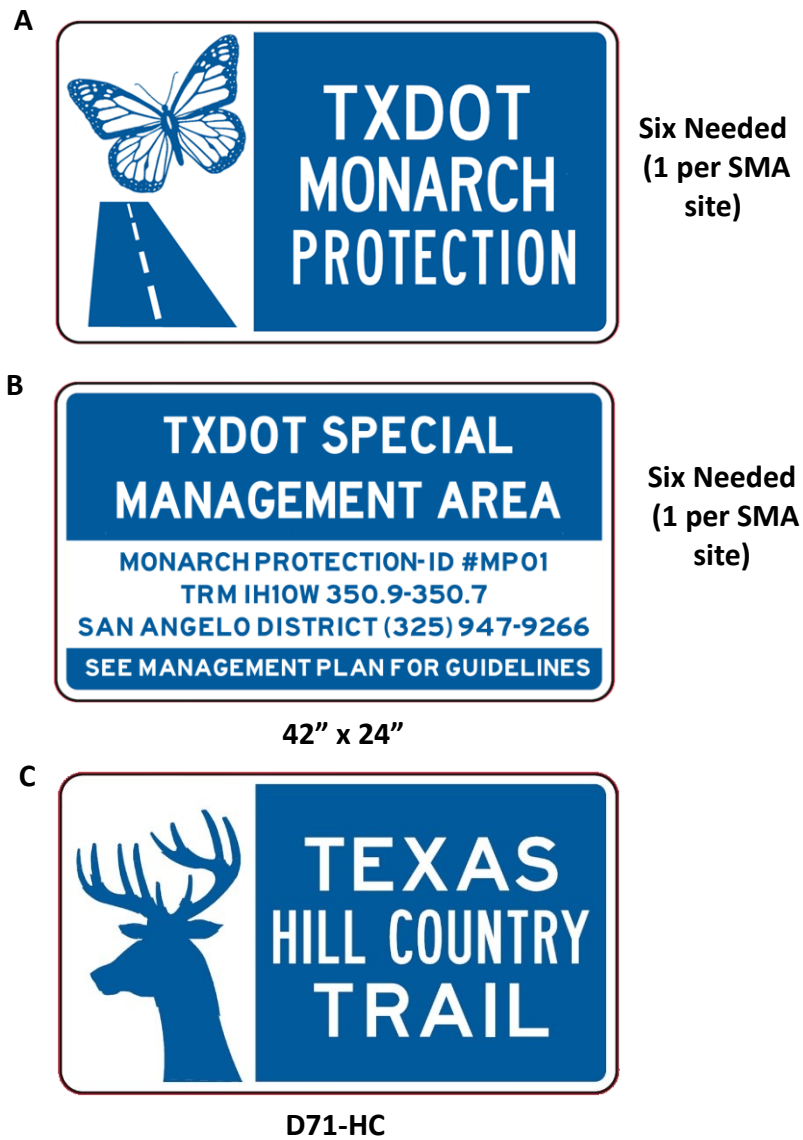
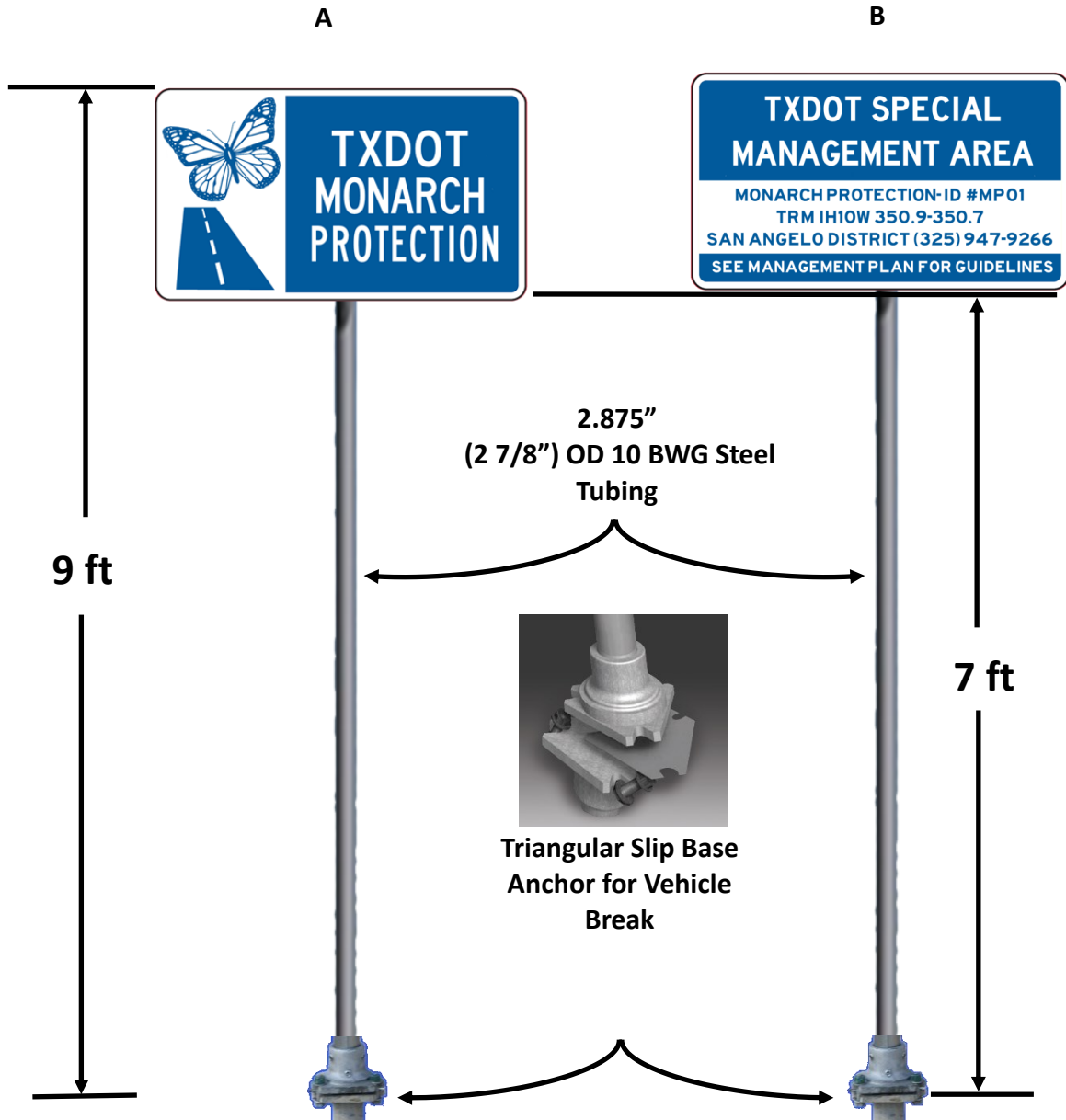


Figure 8.10. Design and materials for attachment to concrete bridge railing of one of ten 15.75 ft panels per section of 12 ft height flight diversion netting tarp at monarch flight diversion Specialized Management Areas (SMA) #MP06 (mounting materials modified from TxDOT (2014b); see Fig. 8.9 for details on frame top rails).



**Figure 8.11. Sign designs for (A) TxDOT monarch protection Specialized Management Area (SMA) sign for public; (B) non-public TxDOT SMA information sign; and (C) TxDOT special route marker for the Texas Hill Country trail (TxDOT 2014c).**



**Figure 8.12. Sign design and installation for land-based monarch protection Specialized Management Areas (#MP01-04): (A) signage for public; and (B) non-public TxDOT information sign and placard for seasonal reduction of monarch collisions within the Central Funnel (installation specifications from TxDOT 2008).**

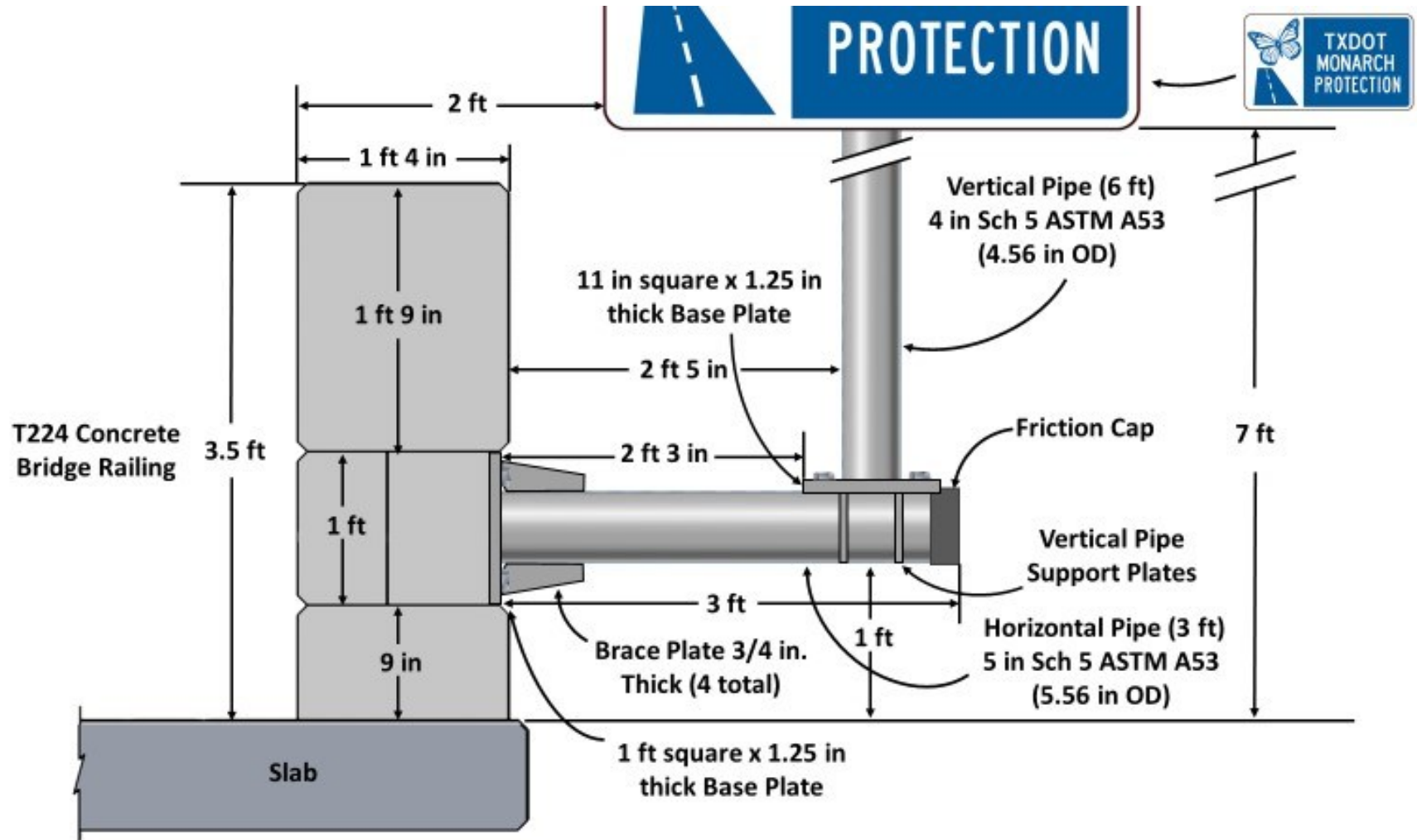


Figure 8.13. Sign design and installation for TxDOT monarch protection for public at John F. Kennedy Causeway Specialized Management Area #MP06 (installation specifications from TxDOT 2014b).



TxDOT specification and materials using triangular slip-base anchors for breakaway with vehicle collision (Fig. 8.12) (TxDOT 2008). The over-water SMA signage installations follow TxDOT specifications for bridge railings (Fig. 8.13) (TxDOT 2014b).

A prototype installation of diversion net frames and nets at a non-roadway testing facility should be erected several months prior to the first field installation to test net durability under high wind conditions and refine installation methods and materials (Fig. 8.2). Weeks of the year with the heaviest fall monarch migration and roadkill were identified as from 15-25 October in the Texas Central Funnel and from 23 October to 10 November in the Texas Coastal Funnel (Part III Chapter 3). From these periods, we selected the peak two weeks of monarch migration and roadkill for seasonal direct mitigation as 11-25 October for the three Central Funnel SMAs and 25 October to 4 November for the three Coastal Funnel SMAs. Initial installation of diversion net frames (without nets) and signage (covered) could take about a week for each of the five SMAs, totaling about five weeks. To allow for unforeseen issues, installation should be scheduled for completion at least one month before implementation in mid to late October, which would be 15 September, requiring installation to begin in early August. This schedule would require the first off-site prototype installation to begin around March to allow time for adjustments in material specifications and procurement. Netting can be installed over the frames the week before implementation begins, and signage can be uncovered on the early morning of the first day of implementation. Following completion of the two-week implementation periods, the netting frames can be left in place without the tarp for the next year and the signage can be covered.

Regulatory approval for initial installations of diversion netting and signage, especially those along federally regulated IH-10, should be sought by March 1 of the year of installation, which is around six months before the suggested beginning of installation in early August. Placement of the netting installation outside of the 30 ft clear zone for the safety of errant vehicles should facilitate approval. The proposed signs are non-standard and would require close review from FHWA and TxDOT. TxDOT regulatory approval of physical structures and signage would involve input from the Traffic Safety Division and Design Division, as well as from District Environmental Specialists and District Engineers from the pertinent San Angelo, Yoakum, and Corpus Christi districts. The TxDOT Bridge Division would also be involved in approval for the John F. Kennedy Causeway SMA site.

A variety of heavy equipment would be required for field installation of flight diverter fencing in areas with near surface bedrock, such as along IH-10 (Fig. 8.14):

- 1) 6.8' x 20' skid steer (track loader) trailer for transporting skid steer (Fig. 8.14A),
- 2) one or more 6.4' x 14' utility trailers for transporting 13.3' posts and tarps (Fig. 8.14B),

- 3) skid steer for post hole digging and concrete mixing/pouring (Figs. 8.14C, E),
- 4) skid steer auger drive unit (Fig. 8.14C, E)
- 5) skid steer attachment 12" diameter rock auger for 18-48" depth for signpost supports (Fig. 8.14C-D),
- 6) skid steer attachment concrete mixer for filling signpost holes (Fig. 8.14E), and
- 7) bucket truck for hanging high tarp netting from 13.3' height (Fig. 8.14F).

At least two half ton pickup trucks would be needed for field installations, one to pull the skid steer trailer with skid steer and rock auger and concrete mixer attachments, and the other for pulling the 6.4' x 14' utility trailer with 14' posts, tarps, and other construction materials.

## 8.5. Cost Estimates

We estimated a cost of \$2,900 in materials and labor for installation of the off-roadside prototype flight diverter to test the wind durability of two types of shade tarp (Table F.1). Materials and installation are based on TxDOT specifications where available. Materials and labor for land-based flight diverter field installations is estimated at \$46.43 per foot with annual maintenance estimated at \$3.36 per foot (costs for travel and heavy equipment are not included) (Table F.2). Installation costs for individual flight diverter field sites with three 157.5 ft sections of fencing are estimated at \$21,984, with all five sites totaling \$114,629. Annual maintenance per site is estimated at \$1,588 (Table F.2). Costs for a bridge based installation were not estimated, but costs may be higher due to the requirement for heavy duty piping (Fig. 8.13).

During the about 50% of years with high roadkill, monarch mortality ranged from 5 to 136 monarchs per 100 m (328 ft) at the identified six roadkill hotspots (Table 8.1). Annual average monarch roadkill hotspot mortality rates, including the 50% low roadkill years with less than 5 monarch roadkill per 100 m, may be about 10 monarch per 100 m. Flight diverter nets on a bridge in Taiwan reduced migratory purple crow roadkill by around 88% (TAFNB 2015). Land-based diverter net installations are 30 ft from the road edge for driver safety, which may reduce their efficacy in diverting monarch flight above the traffic by at least around 30%, or from 88% to 60%. A potentially likely scenario is that an average of 60% of 10 roadkill monarchs per year (including low roadkill years), or six monarchs, are saved per 328 ft (100 m) of flight diversion fencing along roadkill hotspots for the two week period every fall migration, which would amount to 1.83 monarchs saved per 100 foot of netting installation (Table 8.2). We assume a life-cycle of flight diverter materials of at least 30 years. The shade cloth tarp should last about 30 years, considering that it will only be deployed for around 1.5 months per year, totaling 3.75 years over 30 years, with shade cloth assumed to have a lifetime around 5-8 years



**Figure 8.14. Heavy equipment for installation of flight diverter fencing installation along rocky roadsides.**

(FarmersFriend.com 2018). As part of a 30 year life-cycle cost analysis that incorporates installation and annual maintenance costs (USDOT-FHWA 2002), an average of 1.83 monarchs saved per 100 ft over 30 years would yield a cost of \$262 per monarch saved (Table 8.2). The best case scenario of 80% of 40 roadkill monarchs saved, or 32 saved monarchs per 328 ft of netting, would amount to 9.76 monarchs saved per 100 ft at a cost of \$49 per monarch per 30 years (Table 8.2). The general estimated cost per monarch saved over 30 years by flight diverter SMAs is probably between the values of \$49 to \$262 (Table 8.2).

**Table 8.2. Cost per saved monarch over 30 years from flight diverter installation under various scenarios and installation cost of \$46.43 per ft and annual maintenance of \$3.36 per ft.<sup>a</sup>**

Monarch Roadkill Rate per 100 m (328 ft)	Cost per Saved Monarch over 30 Years According to Different Roadkill Reduction Rates (No. Monarchs Saved per 100ft) <sup>b</sup>			
	10%	40%	60%	80%
5	\$3,143.19 (0.15)	\$785.80 (0.61)	\$262 (0.91)	\$392.90 (1.22)
10	\$1,571.59 (0.3)	\$392.90 (1.22)	\$261.93 (1.83)	\$196.45 (2.44)
20	\$785.80 (0.61)	\$196.45 (2.44)	\$130.97 (3.66)	\$98.22 (4.88)
30	\$523.86 (0.91)	\$130.97 (3.66)	\$87.31 (5.49)	\$65.48 (7.32)
40	\$392.90 (1.22)	\$98.22 (4.88)	\$65.48 (7.32)	\$49.11 (9.76)

<sup>a</sup>See Table F.2 for cost estimates.

<sup>b</sup>\$4,643 Installation per 100 ft + (\$336 Maintenance per year 100 ft x 29 Yrs)/((((Roadkill Rate\*Roadkill Reduction Rate)/328 ft)\*100 ft) \* 30 Yrs). Boxes indicates likely average scenario per year (orange) and best case scenario (green).

### 8.6. Evaluation Protocols

Daily weekday late afternoon assessments of monarch roadkill within the monarch roadkill direct mitigation SMAs would be made during the two weeks of flight diverter installation and uncovering of the monarch crossing warning signage. Three separate 157.5 ft diversion fence treatment arthropod roadkill counts would be made adjacent to each of the three flight diversion sections. These roadkill counts would be compared to four 157.5 ft length control roadkill counts, two between the three 157.5 ft sections and two before and after the first and third diversion fence sections (Figs. 8.3-8.4, 8.7C). Roadkill counts would be recorded in 10 m increments.



## 8.7. Conclusions

Specific locations, installation regulation and timing, objectives, designs, materials, and equipment are described for the direct monarch roadkill mitigation strategy of flight diversion fencing. Costs per monarch saved over 30 years in flight diverter SMAs will probably range from around \$49 to \$262 per monarch. The cost per monarch saved from flight diverters is about 8% lower to 773% higher than the cost for monarchs produced through planted pollinator habitats, which ranges from about \$30 to \$53 per monarch over 30 years (See Chapter 9.5).

## CHAPTER 9. DESIGNS FOR IMPLEMENTATION OF INDIRECT ROADKILL MITIGATION THROUGH ROADSIDE MILKWEED/NECTAR PLANT SPECIALIZED MANAGEMENT AREAS ON TEXAS ROADWAYS

### 9.1. Introduction

We earlier reviewed three specific potential indirect mitigation strategies for monarch roadkill, including (1) the TxDOT roadside vegetation management program (already being implemented), (2) roadside marked pollinator habitat Specialized Management Areas (SMAs), and (3) non-roadside habitat enhancement areas (Chapter 7.3). The strategy of pollinator habitat SMAs, if implemented on a wide enough scale, is probably the best new indirect mitigation strategy for augmenting monarch populations. We modify the pollinator habitat SMA strategy to include transplanting of regionally common roadside milkweeds and monarch-preferred nectar plants for the spring and fall monarch migration. These SMAs would be identified with public signage as pollinator habitat and non-public signage for TxDOT personnel.

The objective of the pollinator habitat SMAs would be to increase the density of roadside preferred milkweed and non-milkweed nectar plants at each location and promote greater monarch larval densities per roadside milkweed plant. In this chapter, we identify various potential sites across Texas for pilot implementation of pollinator habitat SMAs and develop designs for the habitats. We propose regionally adapted roadside nectar plant species at each site, with plans for greenhouse propagation and transplantation to ensure greater success than could be achieved with seeding. Plans also include the design and arrangement of barrier tape and signage protected transplant treatment plots and control plots for statistical evaluations.

### 9.2. Texas Roadside Indirect Mitigation Locations

Spring roadside densities of monarch roadkill, monarch larvae, and milkweeds were used to identify strategic areas for locating seven pollinator habitat SMAs (Table 9.1, Fig. 9.1) (Part III Chapter 4). These seven pilot SMA sites represent a wide variety of areas where each of the four common roadside milkweeds of Texas can occur at high densities, including green antelopehorns (*Asclepias viridis*), antelopehorns (*A. asperula* ssp. *capricornu*), zizotes milkweed (*A. oenotheroides*), and broadleaf milkweed (*A. latifolia*). Five of the SMA sites represent strong areas of migratory connectivity in terms of high-density monarch roadside presence and resources. Two SMA sites (#PH02 and #PH05) represent areas of lower density of monarch roadside resources where migratory connectivity needs more enhancement.

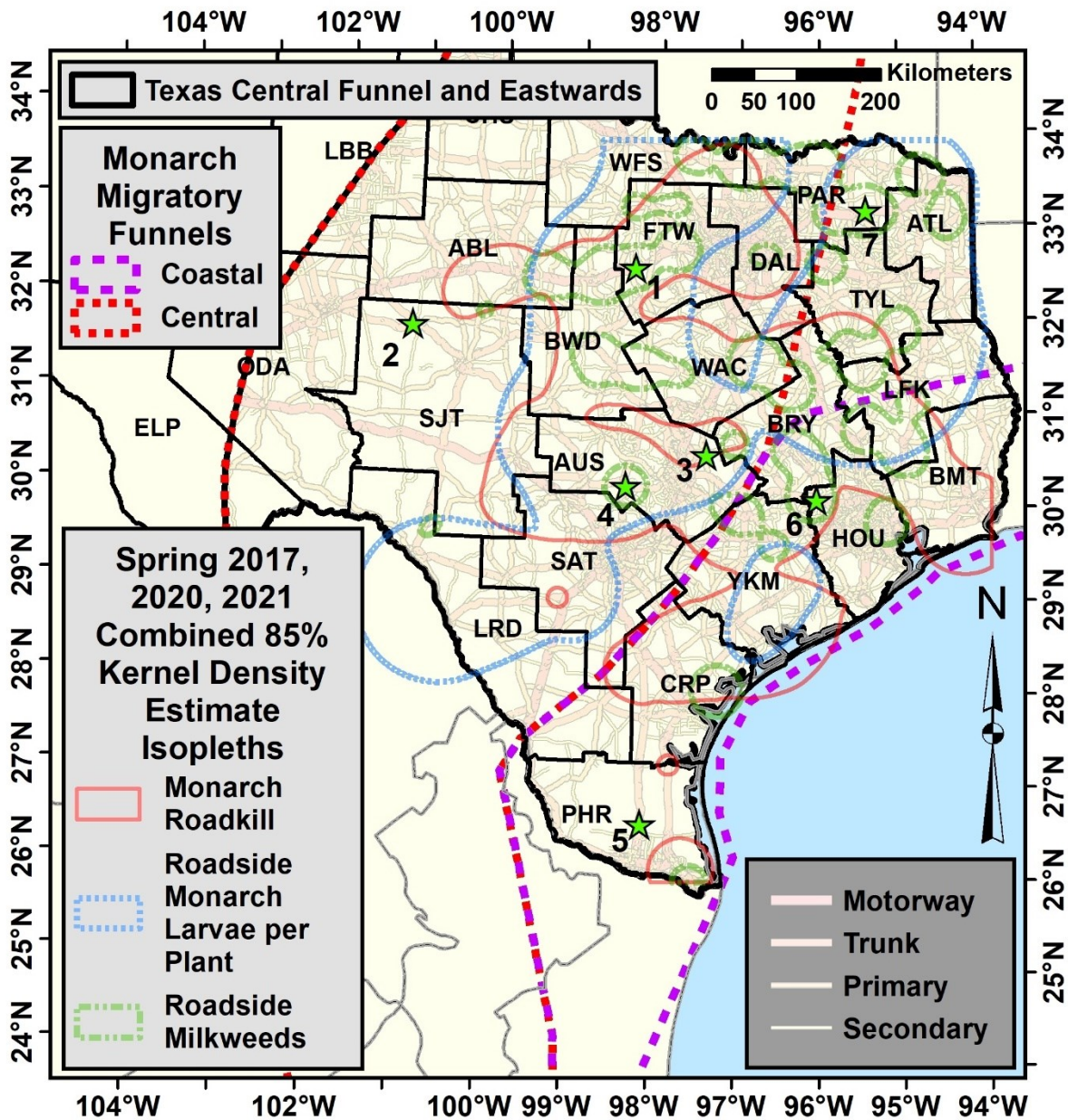
**Table 9.1. Potential pollinator habitat (PH) Specialized Management Area locations within wide right-of-ways (ROW) (Part III Chapter 4).**

Region/Location (TxDOT District)	Geocoordinates <sup>a</sup>		Milkweeds <sup>b</sup>	ROW/Shoulder Widths (ft)			
	Latitude	Longitude		ROW Width	Shoulder 1	Shoulder 2	ROW Available for Staking <sup>c</sup>
<i>Central Funnel</i>							
#PH01 - 7 mi East of Thurber, TX on IH-20W (Forth Worth District)	32.53686	-98.31222	111 antelopehorns, 12 green antelopehorns, and 3 zizotes milkweeds at spring 2021 Transect 4AT18	75	16	9	40
#PH02 - 6 mi West of Sterling City on TX-158 (San Angelo District)	31.857407	-101.100668	41 broadleaf milkweeds at spring 2020 transect 4AT19	142	10	--	122
#PH03 – Taylor on US- 79W (Austin District)	30.56152	-97.390733	Common green antelopehorns in ROW from iNaturalist and TxDOT	95	14	--	79
#PH04 – 3 mi South of Johnson City on US- 281S (Austin District)	30.220199	-98.380298	113 antelopehorns, and 1 zizotes milkweed at spring 2020 transect 2AT17	70	11	--	51
<i>Coastal Funnel</i>							
#PH05 – Linn on US- 69CS (Pharr District)	26.59914	-98.118377	Common roadside zizotes milkweed in region	130	12	--	111
#PH06 – 2 mi West of Prairie View on US-290E (Houston District)	30.090181	-96.027828	43 green antelopehorns at spring 2020 transect 3AT28	69	12	--	51
<i>Northeast Region</i>							
#PH07 – 10 mi East of Sulphur Springs on IH- 30W (Paris District)	33.162316	-95.405306	250 green antelopehorns at spring 2017 transect T97	317	11	3	271

<sup>a</sup>Location is first roadway corner of the first transplanting plot. See Figs. 9.1, 9.9, and Appendix E Figs. E.6-E.11 for mapped locations.

<sup>b</sup>Counted milkweed numbers are per 100 m x 5 m roadside transect.

<sup>c</sup>Available ROW calculated by taking the width of a 30 ft clear zone with one shoulder and 60 ft clear zone with two shoulders and subtracting the shoulder width(s) from the clear zone, with the remainder subtracted from the total ROW width. At least 40 ft width available ROW desired for staked Specialized Management Area where milkweeds and monarch-preferred nectar plants are transplanted



**Figure 9.1. Potential locations for pollinator habitat Specialized Management Areas (SMAs), including four locations in the Central Funnel: (1) east of Thurber, (2) west of Sterling City, (3) Taylor, and (4) south of Johnson City; two locations in the Coastal Funnel: (5) Linn, and (6) west of Prairie View; and one location in Northeast Texas (7) east of Sulphur Springs (from Tracy et al. 2021c; see Table 9.1 and Figs 9.7, Appendix E Figs. E.5-E.10 for detailed locations).**



Two milkweeds are particularly important for South Texas, where spring monarch migratory connectivity from milkweed populations may be weakest: zizotes milkweed and Emory's milkweed (*A. emoryi*) (Fig. 9.2). Emory's milkweed is generally less common and has a more restricted range in West and South Texas (Fig. 9.2). These two milkweeds are very similar and can be best distinguished by flower morphology (Fig. 9.3). Monarch larvae have been reported from roadside Emory's milkweed in west Texas (J. Bush, UT San Antonio, unpublished data). Emory's milkweed is more of a spring flowering species compared to zizotes milkweed (Fig. 9.4) (iNaturalist 2021), and these two species were selected for spring and fall milkweeds, respectively, at the South Texas Linn SMA site (Tables 9.2, 9.3)

A major criterion for SMA site selection was a wide enough shoulder and right-of-way (ROW) to allow the marked plots for transplants to be outside the 30 ft clear zone where the most intensive mowing and herbicide management is usually practiced. Since the planting areas are 48 ft wide, the total ROW and shoulder width needed to equal at least 78 ft to allow the 48 ft transplanting plot after subtracting the 30 ft clear zone (Table 9.1, Part III Chapter 4). Another criterion was to avoid areas with heavy infestations of invasive Johnson grass requiring herbicidal control in the Waco District.

### 9.3. Overall Design

Recommended densities of milkweed as monarch habitat in restoration areas range from 80 plants per acre (Monarch Watch 2021) to between 200 to 2,000 plants per acre (Monarch Joint Venture 2017b). Assuming 75% survival of 120 milkweed planted in the 0.165-acre plots (726 milkweeds planted per acre), each plot would yield a density of 545 milkweeds per acre, which would be the target density of pollinator habitat SMAs. Average densities of milkweeds along Texas roadways in spring 2021 were around 35 to 54 plants per acre, with hotspots reaching over 162 plants per acre (Part II Chapter 5) (maximum 1000 plants per acre found for antelopehorns in spring 2021). Successfully established milkweed/nectar plant patches can serve as propagule islands for further nectar plant expansion within the ROW.

The general design concept for pollinator habitat SMAs is three 48 ft x 150 ft plots, each with 40 3 x 3 ft subplots of six transplants of one of six nectar plant species per plot, spaced at least 1.25 ft apart. Monarch Watch (2021) recommends planting milkweeds in clusters of three to four plants spaced 1 ft apart. The subplots would be separated by 8 ft widthwise and 8.8 ft lengthwise in five staggered rows that are randomly arranged by species and planting date (Fig. 9.4). Subplot planting preparation would be accomplished through about six month sheet mulch treatment (Fig. 9.5). Each plot would be protected from routine roadside mowing or spraying by a light-weight marker fence consisting of two-inch nylon yellow and black nylon barrier tape attached at 3 ft

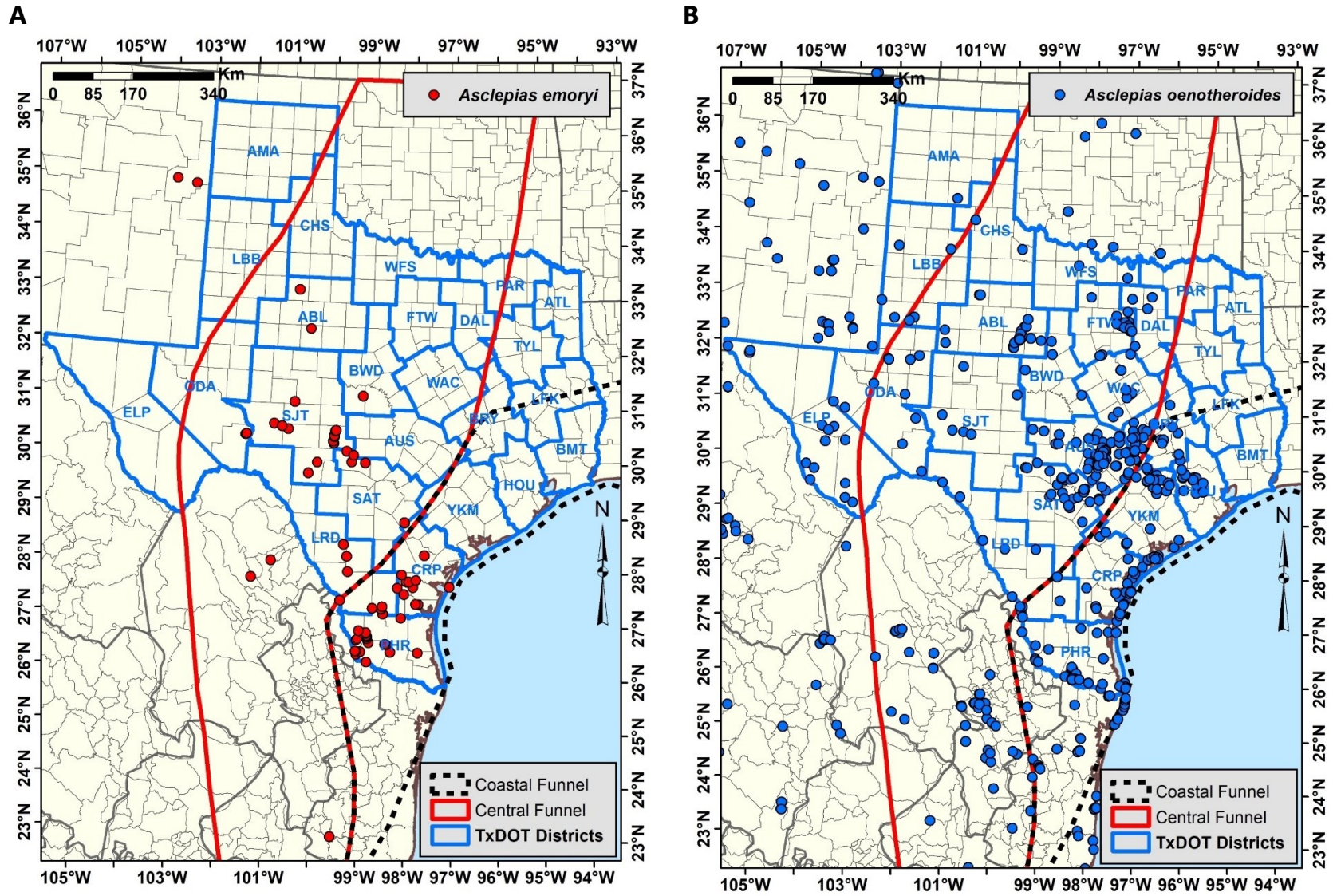


Fig. 9.2. Distribution of two dominant roadside milkweeds for South Texas: (A) *Asclepias emoryi* (iNaturalist 2021), and (B) *A. oenotheroides* (Tracy et al. 2021d).

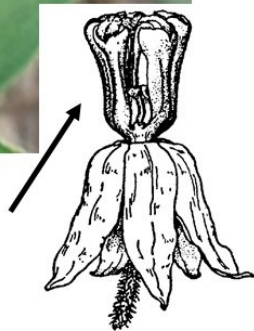


### Emory's Milkweed



Hoods essentially erect,  
the tip deeply 2-lobed

Woodson 1954



### Zizotes Milkweed



Hoods somewhat spreading at the tips,  
broadly rounded to somewhat  
quadrangular, entire to slightly  
emarginate

45

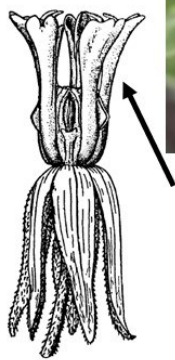


Fig. 9.3. Differences in flower morphology between Emory's milkweed and zizotes milkweed (drawings from Woodson 1954; images from iNaturalist 2021).

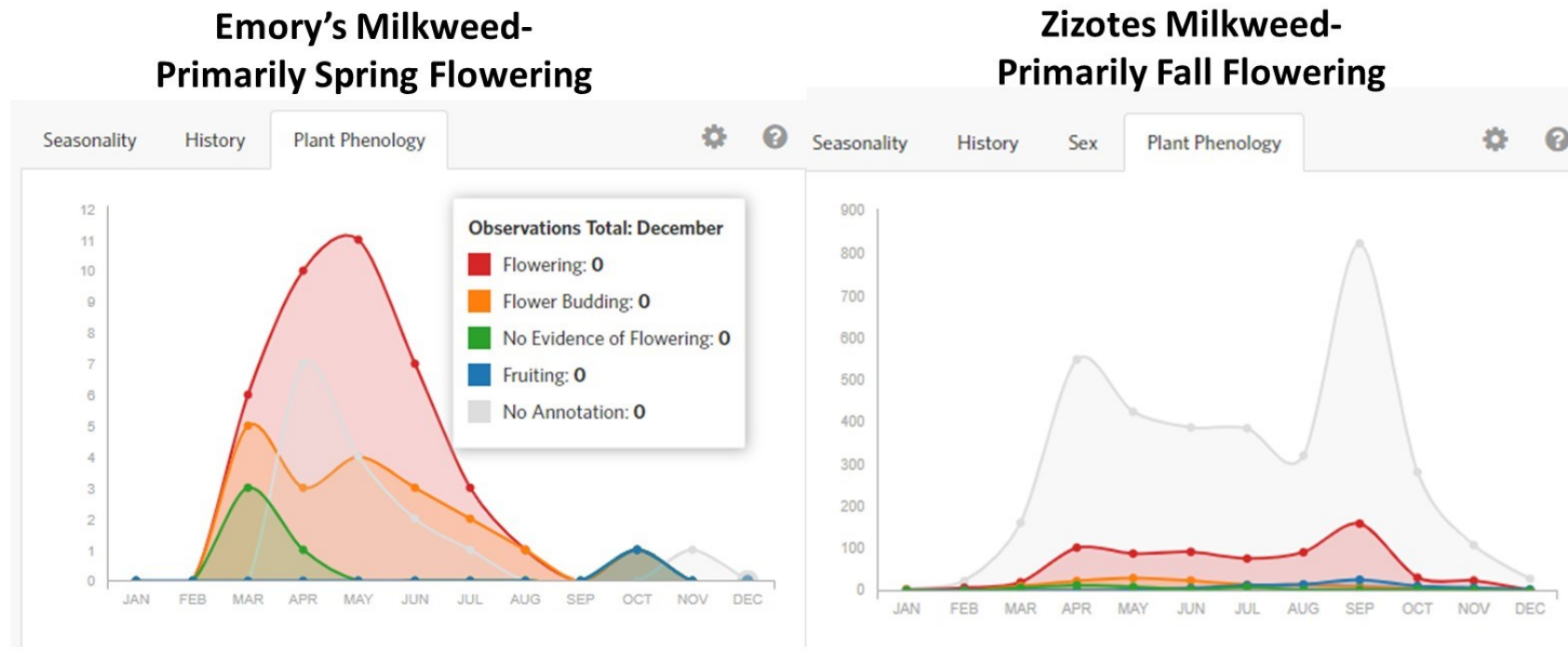


Fig. 9.4. Differences in phenology between Emory's milkweed and zizotes milkweed (iNaturalist 2021).



**Table 9.2. Potential pollinator habitat (PH) Specialized Management Area locations within wide rights-of-way (ROW) with monarch-preferred nectar plant species and transplanting dates for one of three plots per site.**

Site (Each with three 150' x 48' subplots)	Transplanting Dates <sup>a</sup>		Monarch-Preferred Nectar Plant Transplants Per Species/Transplant Date at each Site (Six Species in Each of 40 Subplots per Site) (Number Transplants, Grouped by Six per Subplot)							
	Early Spring	Later Spring	Early Spring Transplanting (120)				Late Spring Transplanting (120)			
			Spring		Fall		Spring		Fall	
	Spring	Spring	Milkweeds	Non-Milkweeds	Milkweeds	Non-Milkweeds	Milkweeds	Non-Milkweeds	Milkweeds	Non-Milkweeds
		Spring (30)	Fall (30)	Spring #1 (30)	Spring #2 (30)	Spring (30)	Fall (30)	Fall #1 (30)	Fall #2 (30)	
<i>Central Funnel</i>										
#PH01 - 7 mi East of Thurber, IH-20W (Forth Worth District)	8 March	29 March	Antelope-horns	Zizotes Milkweed	Texas Vervain	Engelmann Daisy	Antelope-horns	Zizotes Milkweed	Heath Aster	Blazing Star
#PH02 - 5 mi West of Sterling City, TX-158W (San Angelo Dist.)	8 April	29 April	Antelope-horns	Broadleaf Milkweed	Texas Thistle	Prairie Verbena	Antelope-horns	Broadleaf Milkweed	Spanish Gold	Bitter-weed
#PH03 - Taylor Loop, US-79W (Austin Dist.)	8 March	29 March	Green Antelopehorn	Zizotes Milkweed	Texas Vervain	Engelmann Daisy	Green Antelopehorn	Zizotes Milkweed	Heath Aster	Blazing Star
#PH04 - 3 mi South of Johnson City, US-281S; Austin Dist.)	24 March	14 April	Antelope-horns	Zizotes Milkweed	Texas Vervain	Engelmann Daisy	Antelope-horns	Zizotes Milkweed	Zexmania	Blazing Star
<i>Coastal Funnel</i>										
#PH05 - Linn on IH-69CS (Pharr Dist.)	24 January	14 February	Emory's Milkweed	Zizotes Milkweed	Plains Coreopsis	Texas Thistle	Emory's Milkweed	Zizotes Milkweed	Golden Crown-beard	Zexmania
#PH06 - 2 mi West of Prairie View, US-290E (Houston District)	8 March	29 March	Green Antelopehorn	Zizotes Milkweed	Lance Leaved Coreopsis	Prairie Verbena	Green Antelopehorn	Zizotes Milkweed	Heath Aster	Maxi-millian Sunflower
<i>Northeast Texas</i>										
#PH07 - 10 mi East of Sulphur Springs on IH-30W (Paris District)	8 March	29 March	Green Antelopehorn	Clasping Milkweed	Lance Leaved Coreopsis	Lemon Beebalm	Green Antelopehorn	Clasping Milkweed	Black-eyed Susan	Texas Vervain

<sup>a</sup> Early Spring = Median Date Average Last Frost; Late Spring = 3 Weeks Later (modified from NOAA 2021). All plants are perennial, except lemon beebalm and plains coreopsis.

**Table 9.3. Monarch-preferred native nectar plant species and transplanting dates for potential pollinator habitat (PH) Specialized Management Area locations within wide right-of-ways (ROW).**

Plant Common Name	Scientific Name	Seasonality <sup>a</sup>	Primary Texas Regions along Roadside <sup>b</sup>	SMA Pollinator Habitat (PH) Site Numbers (No. Plants per Plot x 6 Plots) [Total Plants] <sup>c</sup>
<i>Milkweeds</i>				
Green Antelopehorns	<i>Asclepias viridis</i>	Mostly spring, some fall	Central and East	03 (180), 06 (180), 07 (180) [540]
Antelopehorns	<i>A. asperula ssp. capricornu</i>	Mostly spring, some fall	Central and West	01 (180), 02 (180), 04 (180) [540]
Zizotes Milkweed	<i>A. oenotheroides</i>	Mostly fall, some spring	Central, West, and South	01 (180), 03 (180), 04 (180), 05 (180), 06 (180) [900]
Broadleaf Milkweed	<i>A. latifolia</i>	Mostly fall	West	02 (180) [180]
Clasping Milkweed	<i>A. amplexicaulis</i>	Mostly late spring	East	07 (180) [180]
Emory's Milkweed	<i>A. emoryi</i>	Mostly spring, some fall	South	05 (180) [180]
<i>Other Monarch-Preferred Nectar Plants</i>				
Prairie Verbena	<i>Glandularia bipinnatifida</i>	Mostly spring, some fall	Central and North-Central	02 (90), 06 (90) [180]
Texas Vervain	<i>Verbena halei</i>	Mostly spring, some fall	Central and West	01 (90), 03 (90), 04 (90), 07 (90) [360]
Lance-leaved Coreopsis	<i>Coreopsis lanceolata</i>	Spring	East	06 (90), 07 (90) [180]
Plains Coreopsis	<i>C. tinctoria</i>	Spring (Annual)	East and South	05 (90) [90]
Engelmann Daisy	<i>Engelmannia peristenia</i>	Spring	Central and West	01 (90), 03 (90), 04 (90) [270]
Lemon Beebalm	<i>Monarda citriodora</i>	Spring (Annual)	East and North-Central	07 (90) [90]
Maximilian Sunflower	<i>Helianthus maximiliana</i>	Fall	Central and North	06 (90) [90]
Heath Aster	<i>Symphotrichum ericoides</i>	Fall	Central and Northwest	01 (90), 03 (90), 06 (90) [270]
Golden Crownbeard	<i>Verbesina enceliodes</i>	Spring and Fall	Central and South	05 (90) [90]
Dotted Blazing Star	<i>Liatris punctata</i>	Fall	Central and North-Central	01 (90), 03 (90), 04 (90) [270]
Zexmania	<i>Wedelia acapulcensis var. hispida</i>	Spring and Fall	Central and South	04 (90), 05 (90) [180]
Texas Thistle	<i>Cirsium texanum</i>	Spring	Central and North Central	02 (90), 05 (90) [180]
Spanish Gold	<i>Grindelia ciliata</i>	Fall	West	02 (90) [90]
Bitterweed	<i>Helenium amarum</i>	Mostly Fall, some spring	West, Central, North Central, and Southeast	02 (90) [90]
Black Eyed Susan	<i>Rudbeckia hirta</i>	Mostly summer, some fall	Central and East	07 (90) [90]
<b>GRAND TOTAL PLANTS</b>				<b>[5040]</b>

<sup>a</sup>Seasonality from Tracy et al. (2022) and iNaturalist (2021). All species are perennial unless indicated as annual (Native Plant Information Network 2022).

<sup>b</sup>Regions from Part II Chapters 3-5 and iNaturalist (2021).

<sup>c</sup>Table 9.2.

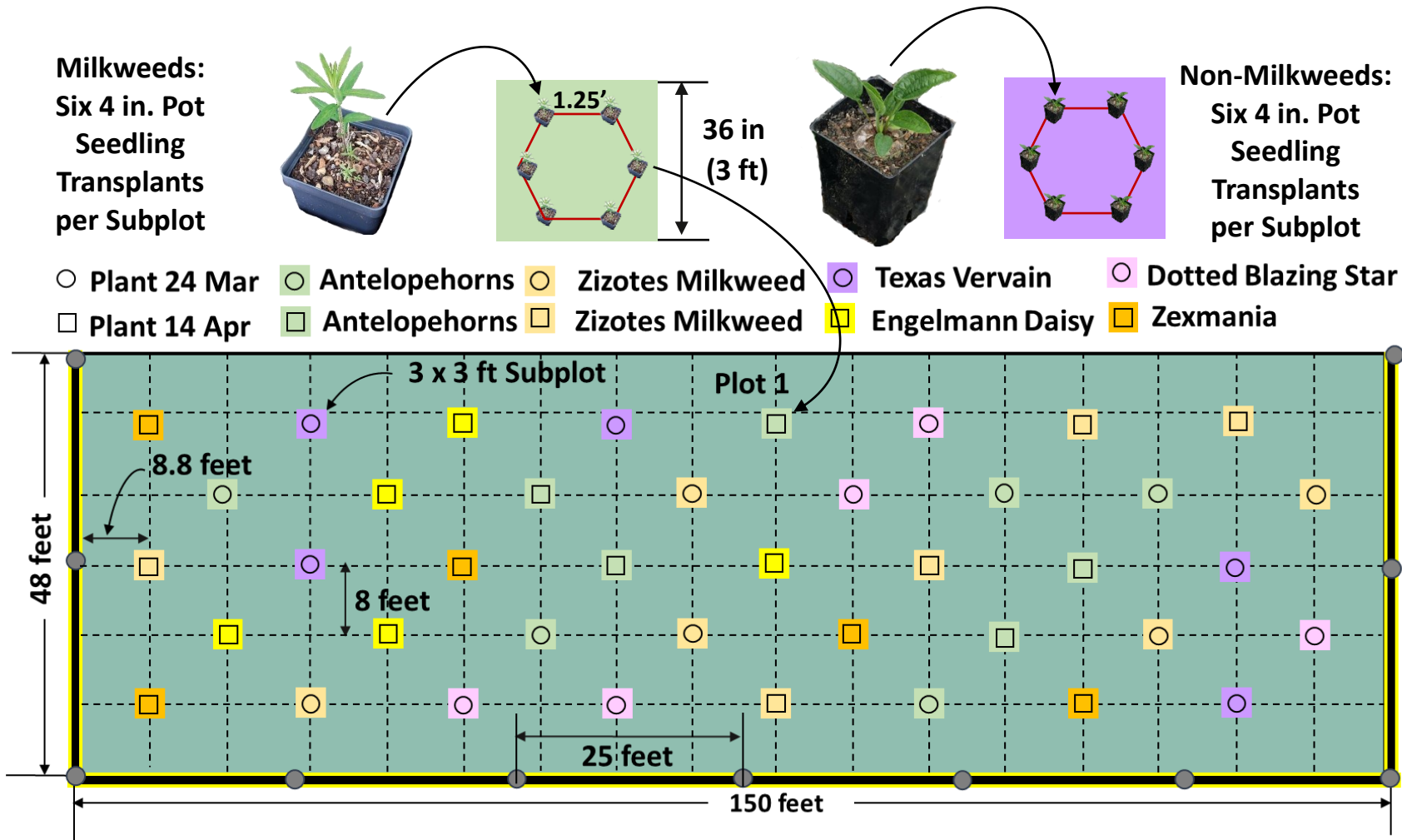


Fig. 9.4. Design concept for pollinator habitat Specialized Management Area #PH04 transplanting plot with 240 plants (120 milkweeds and 120 other non-milkweed monarch preferred nectar plants) with six plants in each of 40 subplots (prepared through sheet mulching, Fig. 9.5) located south of Johnson City (three plots per SMA site).



**Fig. 9.5. Sheet mulching to smother weeds and build soil using wet cardboard topped with mulch (Cunningham 2017)**

height using a stainless steel cable tie to 4 ft U-posts every 25 ft (Figs. 9.6-9.9). Additional protection is provided by no mow/no spray signage (Figs. 9.8-9.10).

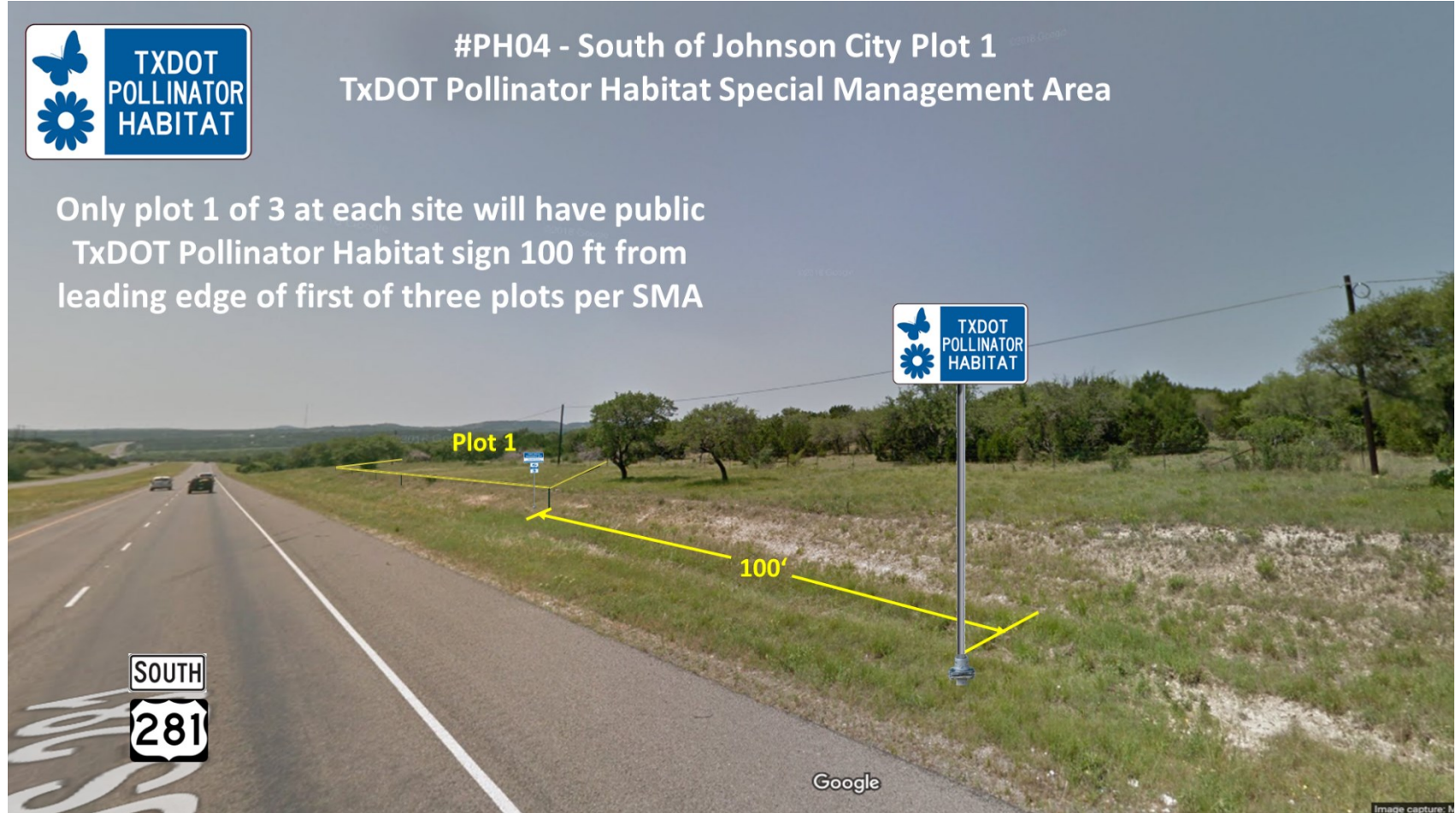
#### **9.4. Design Details, Installation, and Approval**

We used spring and fall roadside nectar plant survey data to select six species of regionally common roadside monarch-preferred nectar plants for each pollinator habitat SMA (Part III Chapters 3-5). Three predominantly spring and three predominantly fall blooming plants were selected for each SMA site, including one spring and fall blooming milkweed species (Table 9.2). All perennial and annual nectar plants would be propagated from seed 10 weeks prior to spring field transplanting the next year within a greenhouse. Recommended procedures would be followed for milkweed stratification (1 month starting 10 October), germination (2 weeks starting 10 November), and transplanting to 4 in peat pots for growth (2 months starting 24 November) until field planting from 24 January to 9 April (American Meadows 2018, Lady Bird Johnson Wildflower Center 2018, USDA NRCS 2020, Monarch Watch 2022). Some seeds would need to be field harvested for propagation (see Table F.3 for specific soilless mixes, materials, and seed sources). Texas native plant growers would be consulted for best protocols to germinate and develop seedling transplant plugs for spring plantings. Assistance from regional Texas Master Gardner and Texas Master Naturalist chapters



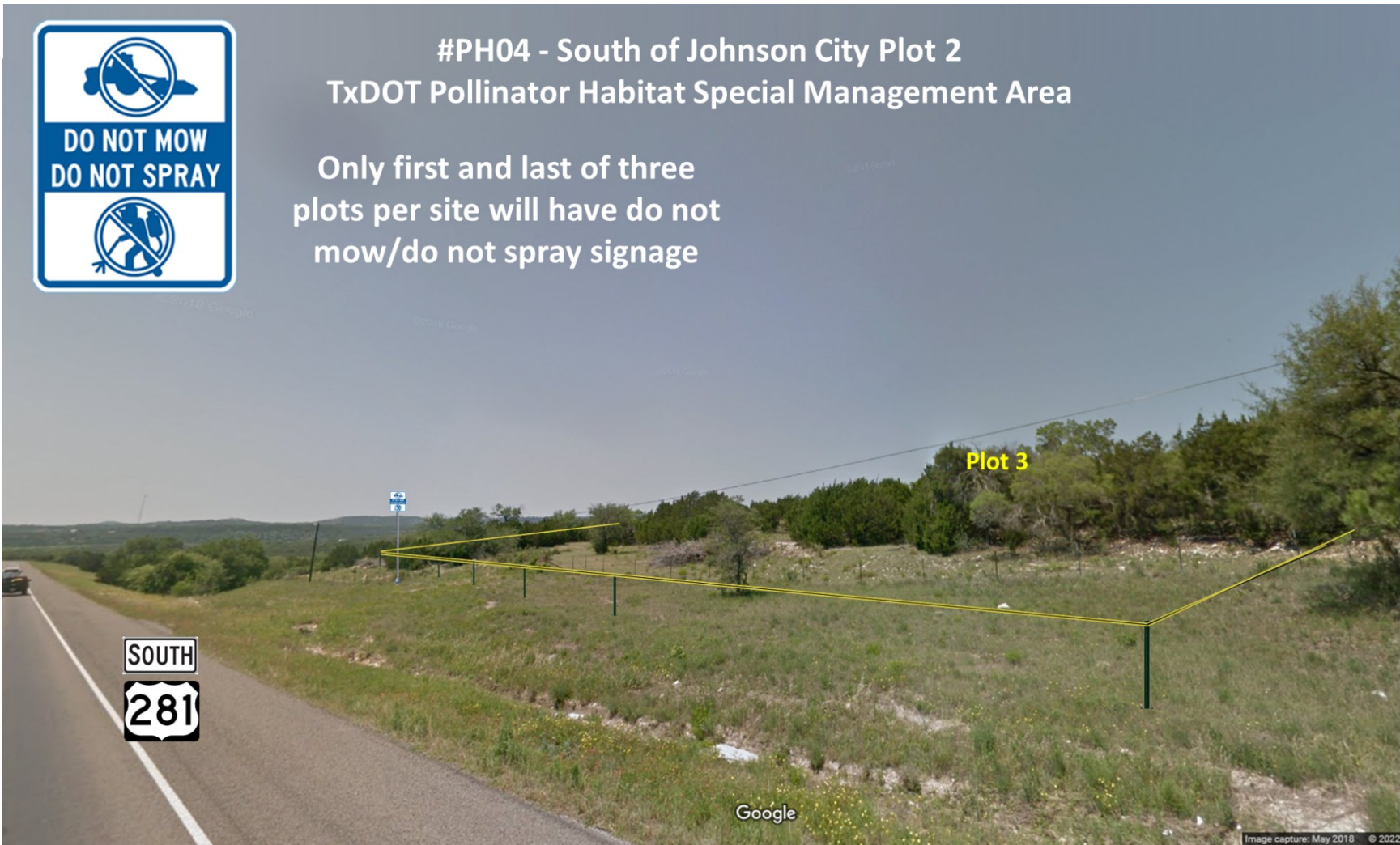


Fig. 9.6. Design concept for pollinator habitat Specialized Management Area (SMA) #PH04 with non-public TxDOT SMA and do not mow/do not spray signage for plot 1 located south of Johnson City.



**Fig. 9.7. Pollinator habitat Specialized Management Area #PH04 plot 1 with public TxDOT Pollinator Habitat signage located south of Johnson City.**





**Fig. 9.8. Pollinator habitat Specialized Management Area #PH04 with non-public do not mow/do not spray signage for plot 3 located south of Johnson City (sign would face down road).**





A



B



Figure 9.10. Small scale (A) and large scale (B) maps for locations of TxDOT pollinator habitat signage and 150 ft x 48 ft plots for the south of Johnson City Specialized Management Area (SMA) #PH04 (see Appendix E Figs. E.5-E.10 for location maps of SMAs #PH01, 03-07).

would be solicited for assistance with seed collection, germination, and transplant propagation.

Nectar plant transplantations would be divided among early spring and late spring planting dates at each SMA (Tables 9.2, 9.3). The early spring planting date would be the local median date of the average last frost (NOAA 2021), and the late spring planting date would be three weeks later. The spring and fall milkweeds would be divided among the two transplant dates. The two spring non-milkweed nectar species would be planted at the early transplant date, and the fall plants planted at the late spring date (Table 9.2).

Transplants would be divided among three plots at each SMA with 40 3 x 3 ft subplots per plot, each receiving six transplants spaced at a minimum of 1.25' in a hexagonal configuration, for a total of 240 plants per plot and 720 plants per site (Fig. 9.4). Among the 40 subplots per plot, there would be five subplots for each of the eight species/transplant date combinations (Table 9.2). The 240 plants per plot, would include 120 plants for each milkweed species (half early and half late plant dates), and 60 spring and 60 fall non-milkweed nectar plant species. The three plots with 40 subplots of nectar plants (total 120 subplots per SMA) should facilitate statistical analysis of transplant survival and growth (see Chapter 9.5 below). A total of 5,040 transplants will be needed for the seven SMA sites, half (2,520) milkweeds, and half (2,520) non-milkweed monarch-preferred nectar plants (Table 9.3). An excess of about 25% (1,260) transplants should be made available to account for pre-planting mortality. The 40 3 x 3 ft subplots per plot would need to be cleared of vegetation by a line trimmer in the fall, about six months prior to planting, and treated by sheet mulching, covering with wet cardboard topped by 2 inches of screened compost and 2 inches of native wood mulch (Fig. 9.5) (Diboll 2012, Barth 2016). Ecoturf biodegradable anchoring pins will be used to help anchor cardboard sheets case of high winds. A line trimmer would be used to suppress invasive grasses within the plot area at least twice a year. Holes would be cut in the sheet mulch for transplanting. The three treatment plots would be spaced at least 150 ft apart over about a 0.5 mi length of roadway. Four control plots would be placed between or near the treatment plots with the corners marked by 2-inch-high orange painted wooden stakes. Geocoordinates would be recorded for corners of both treatment and control plots.

Each pollinator habitat SMA site would be visited biweekly for the first month after transplanting and monthly after that until six months, with July and January four inch height mowing each year for maintenance. Transplants at each SMA would receive equal amounts of watering, if needed, at each visit.

Regulatory approval of SMAs along highways would be sought from FHWA (if interstate), the TxDOT Maintenance Division, and the pertinent regional TxDOT District Environmental Specialists, District Engineers, and Area Maintenance Supervisors. District

approval would also be sought for obtaining potential above discussed help in roadside transplanting from regional volunteers wearing the appropriate safety equipment. Regulatory approval should be facilitated by the location of SMA plots outside of the 30 ft clear zone that allows the errant driver to safely exit from the roadway.

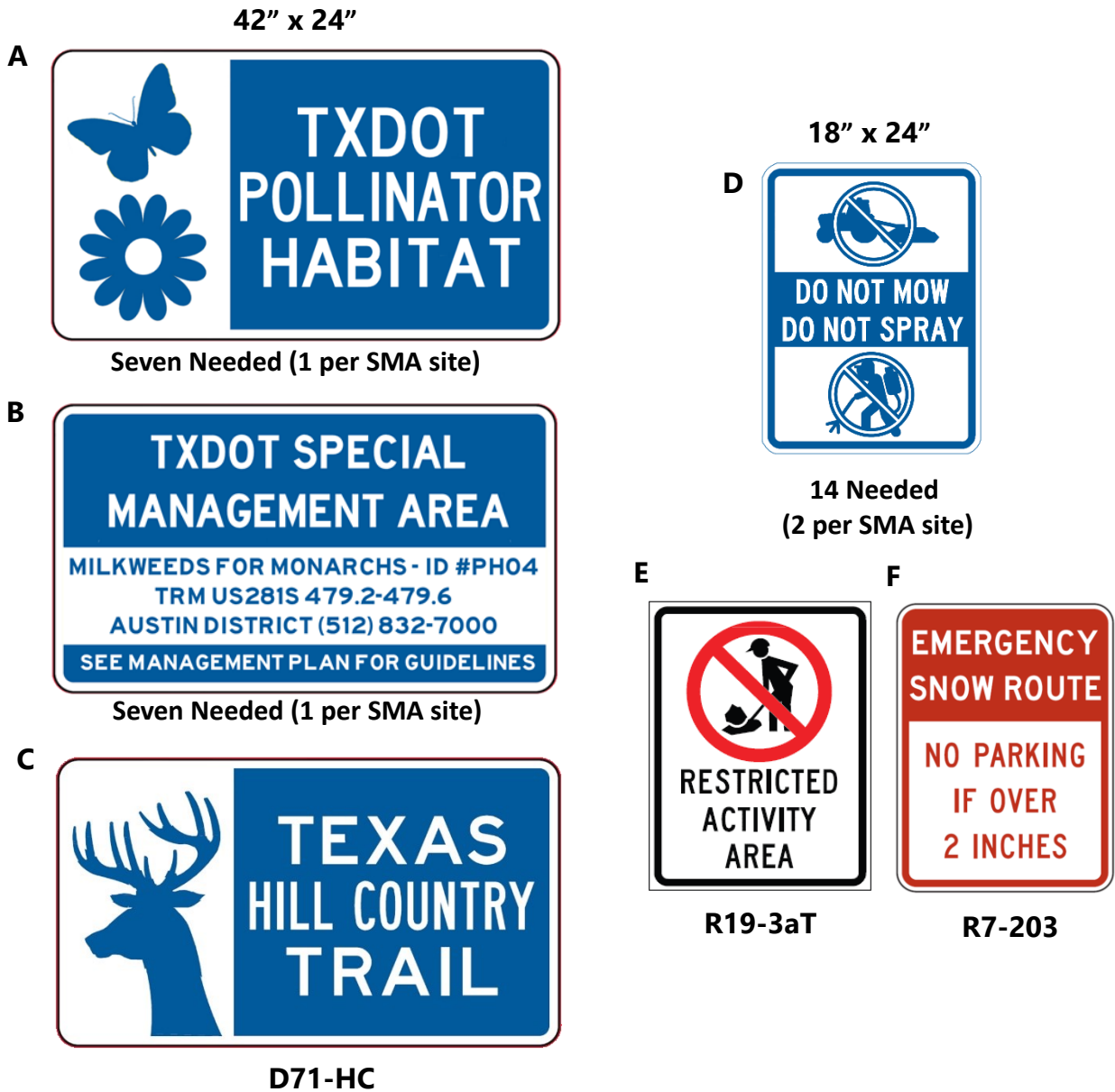
A public TxDOT pollinator habitat sign (Figs. 9.7, 9.9, 9.11A, 9.12A) would be placed 100 feet before the first of three SMA plots to identify habitat conservation purpose of the SMA without drawing unwanted public attention to milkweeds and monarchs that might lead to questioning of regular mowing and herbicide maintenance required to maintain vegetation height and control weeds such as Johnson grass outside of the transplant plots. A non-public TxDOT SMA sign would be placed within the leading corner of the first of three SMA plots to signify management objectives and provide managing office contact information for TxDOT personnel (Fig. 9.6, 9.9, 9.11B, 9.12B). Both signs are patterned after TxDOT Special Route Markers for Texas Travel Trails (Texas Heritage Trails Program), such as the Texas Hill Country Trail sign (D71-HC) (TxDOT 2014c) (Fig. 9.11C). A non-public "do not mow/do not spray" blue/white information placard will also be placed at outside down road corner of each of the third plot to provide further protection for the barricade taped pollinator habitat plantings (Figs. 9.6, 9.8, 9.9, 9.11D, 9.12B). The "do not mow/do not spray" placards are patterned to match two regulatory signs regarding:

- 1) The size and use of symbols in the restricted activity area sign (R19-3aT) (Fig. 9.11E) (TxDOT 2021); and
- 2) The color blocking pattern of the emergency snow route sign (R7-203) (Fig. 9.11F) (TxDOT 2014c).

All SMA signage would be installed according to TxDOT specification and materials using triangular slip-base anchors for breakaway with vehicle collision (Fig. 9.12) (TxDOT 2008).

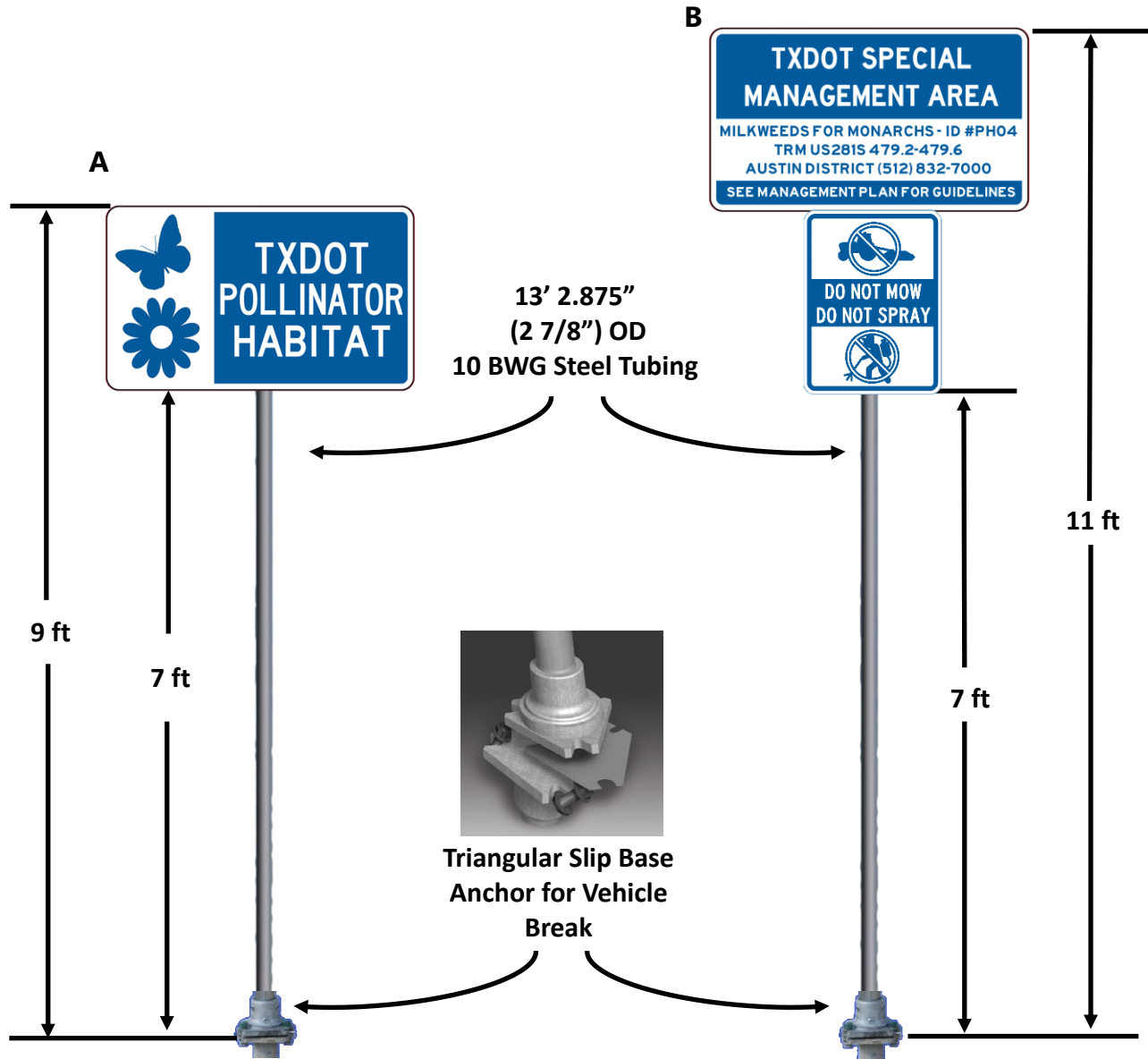
A variety of equipment would be useful for installation of pollinator habitat SMAs, including:

- 1) 1000 gallon water buffalo tank trailer with hose attachment (Fig. 9.13A),
- 2) heavy duty trimmer mower (Fig. 9.13B) with vegetation/tree guard attachment (Fig. 9.13C)
- 3) seven cubic ft heavy duty poly yard dump cart for moving mulch and plants (Fig. 9.13D)
- 4) 14' x 6.4' tandem axel straight utility cage trailer with mesh 6' sides for transporting mulch and cardboard (Fig. 9.13E)



**Figure 9.11. Sign designs for (A) TxDOT pollinator habitat Specialized Management Areas (SMA) sign for public; (B) non-public TxDOT SMA information sign; (C) TxDOT special route marker for the Texas Hill Country trail (TxDOT 2014c); (D) non-public information placard for do not mow/do not spray; (E) restricted activity area sign (R19-3aT) (TxDOT 2021); and (F) emergency snow route sign (R7-203) (TxDOT 2014c).**





**Figure 9.12. Sign design and installation for TxDOT pollinator habitat Specialized Management Areas: (A) signage for public; and (B) non-public TxDOT information sign and placard for habitat protection management objectives (installation specifications from TxDOT 2008).**



**Figure 9.13. Equipment useful for installing and maintaining TxDOT pollinator habitat Specialized Management Areas: (A) 1000 gallon water buffalo tank trailer with hose attachment; (B) heavy duty trimmer mower with (C) vegetation/tree guard attachment, (D) seven cubic ft heavy duty poly yard dump cart for moving mulch and plants, and (E) 14' x 6.4' tandem axel straight utility cage trailer with mesh 6' sides for transporting mulch, cardboard, cart, and trimmer/mower.**

At least two half ton pickups would be needed for towing the water buffalo tank trailer and utility cage trailer to field pollinator habitat SMA sites.

## 9.5. Cost Estimates

Total estimated costs per foot of materials and labor for installation of roadside pollinator habitat is \$10.52 per foot of 150 x 48 ft plots and annual maintenance is estimated and \$0.48 per foot (Table F.3) (costs for travel and heavy equipment are not included). Individual field sites with three 150 x 48 ft plots of nectar plants would cost an estimated \$4,734, with all seven sites totaling \$33,139 (Table F.3). The cost of seven sites of three 150 x 48 ft pollinator habitat plots could be cut by 52% to \$15,818, or \$5.02 per ft, if they are not planted (Table F.4). Non-planted pollinator habitat could be set up around existing milkweed hotspots and protected from potential unfavorably timed mowing or spraying with barriers and signage and treated with July and January custom timed mowing to encourage further propagation through managed disturbance. Adjacent control plots should be evaluated to assess whether milkweed populations within treated barrier surrounded pollinator habitat plots persist longer and spread more than in control plots (see Evaluation Protocols below).

Nail et al. (2015) estimated that about 1 adult monarch is produced in the field on 29 common milkweed (*A. syriaca*) plants in the Midwestern US, or 0.034 monarchs per plant. Texas milkweeds are probably less than half the height of common milkweed, but they generally produce more stems (Singhurst et al. 2015; Part II Chapter 5). Consequently, Texas milkweeds they may produce about the same number of monarch larvae per plant as common milkweed. A potentially likely scenario is that an average of 75% of 120 planted milkweeds (726 milkweeds per acre density), or 90 milkweeds, survive transplantation per 150 ft plot and that they produce 0.026 monarchs per milkweed (75% if that on common milkweed), or 1.53 monarch per 100 ft. We assume an average life-cycle of nylon barrier tape outdoors of about 2 years. For a 30 year life-cycle cost analysis that incorporates installation and annual maintenance costs (USDOT-FHWA 2002), an average of 1.53 monarchs produced per 100 ft over 30 years would equate to \$53 per monarch produced over 30 years (Table 9.4). The best case scenario of 100% of 120 planted milkweeds producing 0.034 monarchs per plant, or 2.72 monarch per 100 ft, would yield \$30 per produced monarch over 30 years (Table 9.4). The general estimated cost per monarch produced by planted pollinator habitat SMAs is from \$30 to \$53 over 30 years (Table 9.4). If milkweed persistence and propagation within protected and disturbance managed non-milkweed planted 150 x 48 ft pollinator habitat plots at milkweed hotspots with 30 milkweeds per plot (181 milkweeds per acre density) could be increased by 83-100% (25 -30 milkweed plants) compared to control plots, the costs per monarch production over 30 years would range from about \$92 to \$148 over 30 years (Table 9.5). Non-planted pollinator habitats with higher initial

milkweed densities, such as 120 milkweeds per 150 x 48 ft plot (726 milkweeds per acre density; sometimes found, Part II Chapter 5), would be the most cost effective, assuming milkweeds would increase by 83-100% with protection and disturbance management, yielding \$23 to \$41 per monarch produced over 30 years (Table 9.6). The use of planted and non-planted roadside SMAs with barriers and managed disturbance can also be used to protect other sensitive roadside flora, such as the proposed endangered prostrate milkweed (*Asclepias prostrata*) in South Texas (USFWS 2022). The production of additional nectar resources for monarchs and other pollinators, such as bumble bees, through pollinator habitat plots is also important, but it is difficult to quantify and probably of less value than monarch production on milkweeds per foot of plots.

**Table 9.4. Cost per monarch produced over 30 years within 150 x 48 ft plot of planted milkweed plants in pollinator habitat area under various scenarios with habitat installation cost of \$10.52 per ft.<sup>a</sup>**

		Cost per Produced Monarch over 30 Years According to Different Monarchs Produced per Milkweed [Monarchs Produced per 29 Plants] (No. Monarchs Produced per 100 ft) <sup>a</sup>				
Number Surviving out of 20 Planted Milkweeds	% Survival Milkweed in Plot	0.034 [1 per 29 Plants]	0.0255 [0.75 per 29 Plants]	0.017 [0.5 per 29 Plants]	0.0085 [0.25 per 29 Plants]	0.0034 [0.1 per 29 Plants]
120	100%	\$30 (2.72)	\$40 (2.04)	\$60 (1.36)	\$119 (0.68)	\$298 (0.27)
90	75%	\$40 (2.04)	\$53 (1.53)	\$80 (1.02)	\$159 (0.51)	\$398 (0.2)
60	50%	\$60 (1.36)	\$80 (1.02)	\$119 (0.68)	\$239 (0.34)	\$596 (0.14)
40	33%	\$89 (0.91)	\$119 (0.68)	\$179 (0.45)	\$358 (0.23)	\$895 (0.09)

<sup>a</sup>See Table F.3 for cost estimates.

<sup>b</sup>(\$1,052 Installation per 100 ft + (\$48 Maintenance per year per 100 ft x 29 Yrs)/(((Number Monarchs Produced per Milkweed \* (0.8 Milkweeds Planted per foot \* % Surviving Milkweeds)) \* 100 ft) \* 30 Yrs). Boxes indicates likely average scenario per year (orange) and best case scenario (green).

### 9.6. Evaluation Protocols

Monthly records at each pollinator habitat SMA would be made over at least two years post planting within three planted treatment plots and four nearby non-planted control plots with no barriers, for



- (1) the survival time length (in months), phenology, and growth of all 40 individual transplants and unplanted milkweed in each of the treatment and control plots;
- (2) the persistence and spread of any non-planted milkweed and monarch-preferred nectar plants in both the planted treatment and non-planted control plots;
- (3) monarch larval presence on the 20 planted milkweeds in the treatment plot and any non-planted milkweeds in both the treatment and control plots;
- (4) arthropod roadkill associated for 150 ft transects centered on the treatment and control plots and recorded in 10 m increments.

**Table 9.5. Cost per monarch produced over 30 years within non-planted 150 x 48 ft milkweed hotspot plots of 30 pre-existing milkweeds per plot in pollinator habitat area under various scenarios with habitat installation cost of \$5.02.<sup>a</sup>**

Number Additional Milkweeds Compared to Unprotected Plots	% Increase over Pre-existing 30 Milkweeds in Plot	Cost per Produced Monarch According to Different Monarchs Produced per Milkweed [Monarchs Produced per 29 Plants] (No. Monarchs Produced per 100 ft) <sup>b</sup>				
		0.034 [1 per 29 Plants]	0.0255 [0.75 per 29 Plants]	0.017 [0.5 per 29 Plants]	0.0085 [0.25 per 29 Plants]	0.0034 [0.1 per 29 Plants]
30	100%	\$92 (0.68)	\$123 (0.51)	\$185 (0.34)	\$369 (0.17)	\$923 (0.07)
25	83%	\$111 (0.57)	\$148 (0.43)	\$222 (0.28)	\$443 (0.14)	\$1,108 (0.06)
20	67%	\$139 (0.45)	\$185 (0.34)	\$277 (0.23)	\$554 (0.11)	\$1,385 (0.05)
15	50%	\$185 (0.34)	\$246 (0.26)	\$369 (0.17)	\$739 (0.09)	\$1,847 (0.03)

<sup>a</sup>See Table F.4 for cost estimates.

<sup>b</sup>(\$502 Installation per 100 ft + (\$48 Maintenance per year per 100 ft x 29 Yrs)/(((Number Monarchs Produced per Milkweed \* (0.2 Milkweeds Planted per foot \* % Surviving Milkweeds)) \* 100 ft) \* 30 Yrs). Boxes indicates likely average scenario per year (orange) and best case scenario (green).

Statistical comparisons on transplant survival, phenology, and growth would be made between milkweeds among the different planting dates and growth and within planting dates for the two milkweed and two non-milkweed nectar plant species. Monthly comparisons would also be made for the total number of wild growing milkweeds and monarch-preferred nectar plants in each of the three treatment and four control plots. Monthly roadkill associated with treatment plots and control plots would also be compared.

**Table 9.6. Cost per monarch produced over 30 years within non-planted 150 x 48 ft milkweed hotspot plots of 120 pre-existing milkweeds per plot in pollinator habitat area under various scenarios with habitat installation cost of \$5.02.<sup>a</sup>**

Number Additional Milkweeds Compared to Unprotected Plots	% Increase over Pre-existing 120 Milkweeds in Plot	Cost per Produced Monarch According to Different Monarchs Produced per Milkweed [Monarchs Produced per 29 Plants] (No. Monarchs Produced per 100 ft) <sup>b</sup>				
		0.034 [1 per 29 Plants]	0.0255 [0.75 per 29 Plants]	0.017 [0.5 per 29 Plants]	0.0085 [0.25 per 29 Plants]	0.0034 [0.1 per 29 Plants]
120	100%	\$23 (2.72)	\$31 (2.04)	\$46 (1.36)	\$92 (0.68)	\$231 (0.27)
90	75%	\$31 (2.04)	\$41 (1.53)	\$62 (1.02)	\$123 (0.51)	\$308 (0.2)
60	50%	\$46 (1.36)	\$62 (1.02)	\$92 (0.68)	\$185 (0.34)	\$462 (0.14)
40	33%	\$69 (0.91)	\$92 (0.68)	\$139 (0.45)	\$277 (0.23)	\$693 (0.09)

<sup>a</sup>See Table F.4 for cost estimates.

<sup>b</sup>(\$502 Installation per 100 ft + (\$48 Maintenance per year per 100 ft x 29 Yrs)/(((Number Monarchs Produced per Milkweed \* (0.2 Milkweeds Planted per foot \* % Surviving Milkweeds)) \* 100 ft) \* 30 Yrs). Boxes indicates likely average scenario per year (orange) and best case scenario (green).

## 9.7. Conclusions

Specific locations, installation regulation and timing, objectives, designs, materials, labor, costs, and equipment are described for indirect mitigation of monarch roadkill through nectar plant transplanting in pollinator habitat SMAs. Roadside signage installations are

based on TxDOT specifications. Costs per monarch produced in pollinator habitat SMAs will probably range from around \$30 to \$53 per monarch produced over 30 years. The cost per monarch produced from pollinator habitat SMAs ranges from about 89% lower to 8% higher than the cost for a monarch saved through diverter fencing SMAs, which ranges from about \$49 to \$262 per monarch saved over 30 years (see Chapter 8.5). If protection and disturbance management for non-planted pollinator habitat SMAs in milkweed hotspots can produce around 83-100% more milkweed plants than unprotected/unmanaged control plots, then the 30 year cost of monarch production in non-planted pollinator habitat SMAs would range from \$92 to \$148 for plots with 181 milkweeds per acre density and from \$23 to \$41 for plots with 726 milkweeds per acre density. The non-planted pollinator habitat SMA 30 year costs per monarch produced are about 91% lower to 202% higher than the 30 year cost of monarchs saved by flight diverter SMAs.

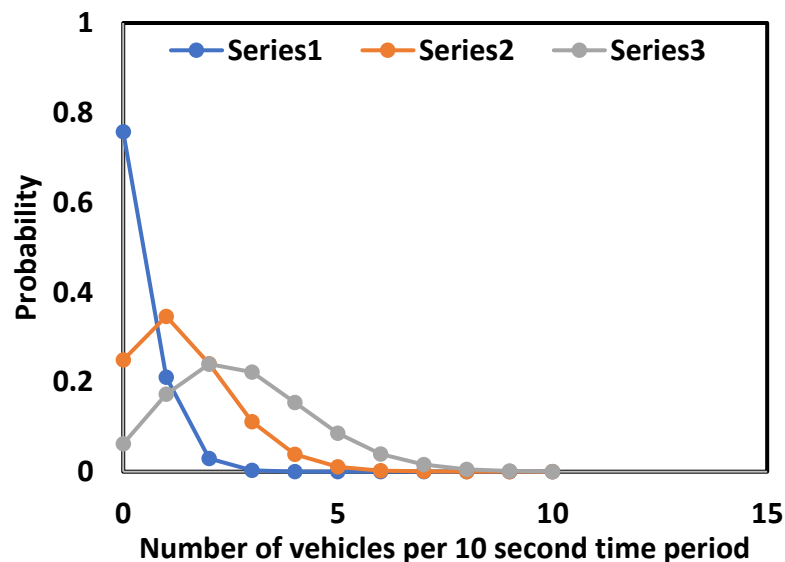
## APPENDIX A. THEORETICAL EFFECTS OF TRAFFIC VOLUMES ON MONARCH ROAD MORTALITY

The Poisson distribution has been used in transportation modeling in relation to roadkill for describing the probability of a given number of vehicles crossing a specified point on a roadway within a defined time period, and for a specified average traffic volume (expressed as vehicles per hour or other time period) (e.g., Jaarsma et al. 2006):

$$P(X = k) = \frac{\lambda^k e^{-\lambda}}{k!} \quad \text{Equation 1}$$

Where  $P(X=k)$  is the probability of  $X$  events per time period (i.e., number of vehicles passing a fixed point) and  $\lambda$  is the average rate of vehicles per time period (traffic volume). The Poisson probability mass functions describing the probability of vehicles passing a point within a 10 second time period ( $\Delta t$ ) for lane volumes ( $I$ ) of 100, 500 and 1000 vehicles per hour can now be calculated (Fig. A.1.). For these curves, the Poisson rate  $\lambda$  is calculated by multiplying the volume in vehicles per hour by the time interval  $t$  as a fraction of the number of seconds in an hour, i.e.:

$$\lambda = I \cdot \frac{\Delta t}{3600} \quad \text{Equation 2}$$

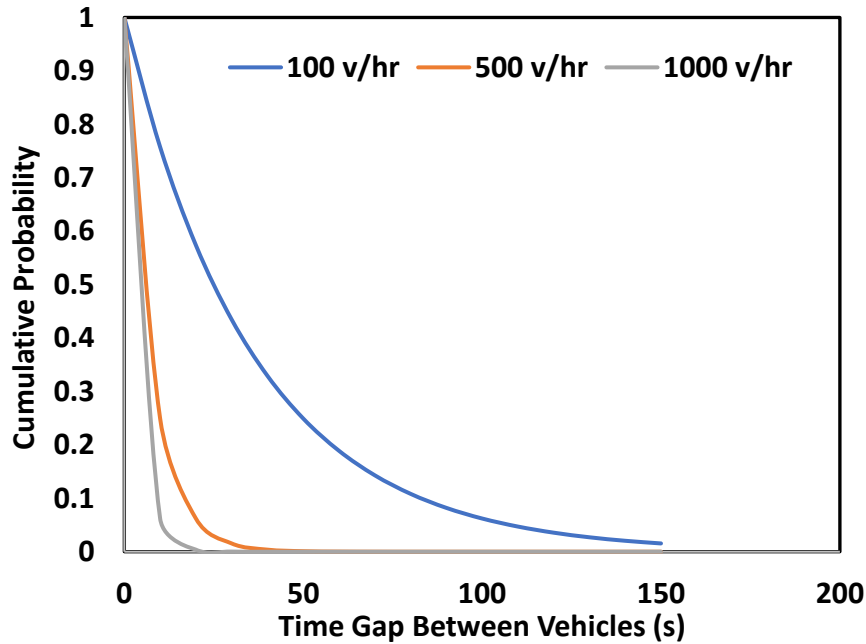


**Figure A.1. Poisson distribution of vehicles passing a fixed point on a road within a specified time period (10 seconds) and for three traffic volumes.**



These assumptions of vehicle arrival times can also be used to calculate the distribution of gaps (measured as the time between vehicles). Time gaps between vehicles follow an exponential distribution (Fig. A.2.). Specifically, the probability (cumulative) of observing a time gap between vehicles greater than  $x$  time periods ( $\Delta t$ ) is given by:

$$P(X \leq x) = e^{-\lambda x} \quad \text{Equation 3}$$



**Figure A.2. Probability of a time gap < X seconds for different traffic volumes (see Fig. A.1.).**

A wildlife-vehicle collision model (WVCM) for an animal species can then be developed that first involves calculating the time  $\delta_a$  (in seconds) needed to traverse the road by the species using the following formula, where  $B$  is the road width,  $L_a$  is the average body length of the species (in m), and  $V_a$  is the traveling velocity of the species (m per s):

$$\delta_a = \frac{(B+L_a)}{V_a} \quad \text{Equation 4 (Jaarsma et al. 2006)}$$

The probability for the animal successfully traversing the road,  $P_a$ , can then be calculated using the following formula, where  $\lambda_1$  is traffic volume:

$$P_a = e^{-\lambda_1 \delta_a} \quad \text{Equation 5 (Jaarsma et al. 2006)}$$

This probability applies to a single lane road. However, because Poisson rates are additive, the equation can be extended to multiple lane roads with traffic moving in one or two directions (assuming vehicle arrival times are Poisson distributed).

The probability of mortality can now be calculated for any monarch attempting to cross the road at a flight altitude between the road surface and a height above the road which

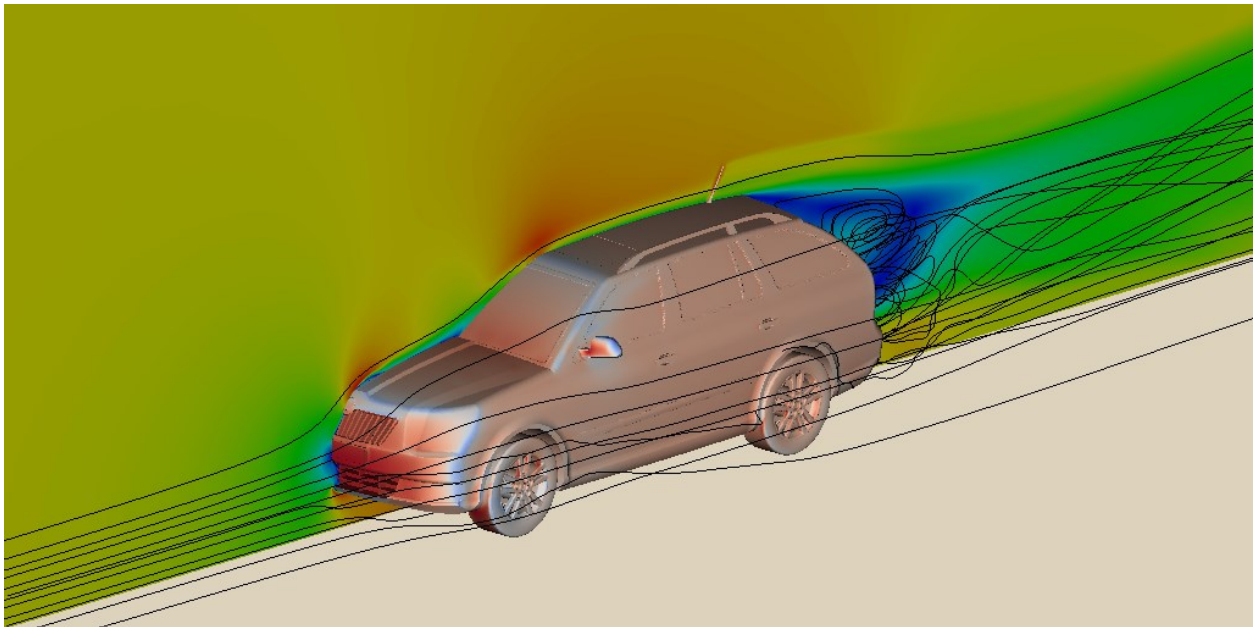
results in mortality (e.g., the average height of vehicles on the road). Specifically, the equations can be used to calculate probability of mortality for a monarch based on a) the crossing time of the monarch within the zone delimited by the road surface and the average height of traffic, and b) the volume of traffic on the road. In turn, the probability of mortality can be translated to rates of mortality (with probabilistic limits) by considering individual crossings as independent events of multiple monarch crossings (for example number of crossings per unit time).

In theory then, this simple model states that monarch roadkill is related to:

- 1) The time required for individual monarchs to cross a roadway or lane of traffic (or the time spent in the critical mortality zone).
- 2) The height or other characteristics of the critical altitudinal flight zone.
- 3) The volume of traffic on the road.

## APPENDIX B. MONARCH FLIGHT ALTITUDES, AIR FLOW, AND ROAD MORTALITY

Through personal experience, the research team have observed that some butterflies and other insects within the critical altitudinal zone of a travelling vehicle escape mortality because of the aerodynamics of vehicles travelling along the road. Conceptually, this occurs because, an area of high air pressure exists at the front of the vehicle as it travels along the road. This area of high pressure may result in the butterfly forced above or around a vehicle instead of a direct collision with the vehicle as the butterfly is pushed by air currents streamlining around the vehicle (Fig. B.1.). Although butterflies are not weightless, their weight is minimal and in the physics of weight and air pressure, is tractable. As such, these methods may be useful for building on the previously described monarch crossing model (based solely on vehicle gaps and crossing time) by helping to evaluate the critical altitudinal flight zones for monarchs in traffic.



**Figure B.1. Streamlines around a vehicle based on computational fluid dynamics (CFD) models. The streamlines show the theoretical movement of weightless particles around a moving vehicle as calculated by CFD.**

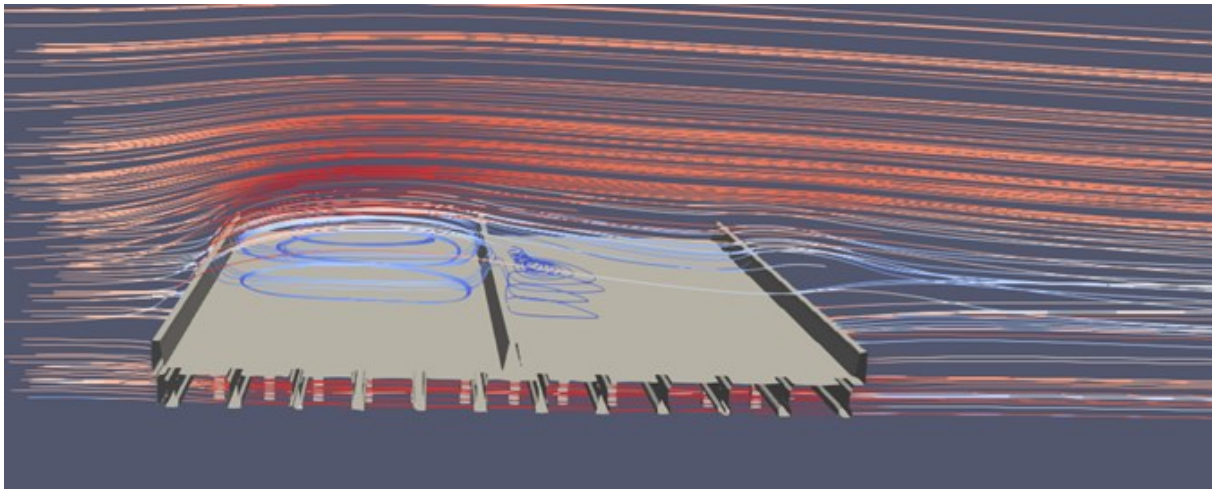
Adult monarchs have been estimated to fly at speeds of approximately 2.4 to 4.3 mph (3.9 – 7 km/h) under controlled, no wind conditions (Bradley & Altizer, 2005; Davis et al., 2012) As such, both the direction and speed of monarch flight is likely to be influenced by prevailing wind conditions.

Barriers such as netting may be useful in providing tactile or visual cues for monarchs to fly around roads, or at higher altitudes above them. However, it is also possible that landscape topology (including vegetation, slopes, bridge infrastructure, concrete traffic barriers, vegetation) affect roadkill (either positively or negatively) by influencing the pattern of air flow (velocity and direction) across the roadway.

Computational fluid dynamics was used to model airflow over a four-lane roadway with 36-inch lateral concrete traffic barriers, and a 42-inch median concrete traffic barrier (Fig. B.2.). The results illustrate how roadway infrastructure, such as barriers, can have a dramatic effect on air flow across roadways. The modeling was conducted for a TxDOT study investigating the effect of air flow patterns on Brown Pelican mortality.

It is plausible that these types of barrier induced airflow patterns could affect the safe passage of monarchs over the roadway. For example, assuming monarchs fly from left to right of the image (i.e., with the simulated wind):

- Monarchs flying at relatively high altitudes before the crossing could be expected to be lifted in fast air flows high over the windward lane. However, the reattachment of the air flow on the leeward lanes might also be expected to force some individuals into the vertical traffic zone on the leeward lane.
- Individuals that begin a crossing at low flight altitudes, could be carried over the barrier and forced towards the road surface by the vortices behind the concrete traffic barriers.



**Figure B.2. Airflow across a four-lane road section flanked by solid concrete traffic barriers modeled with computational fluid dynamics. The streamlines indicate the direction (line shape) and velocity (line color) of weightless particles travelling within streams of air over the bridge. Blue lines represent low velocity streamlines, while red lines show high velocity streamlines.**



Computational fluid dynamics models and wind tunnel experiments provide an opportunity to evaluate local topography on wind conditions across a road section. In particular, they provide objective, reliable ways to visualize air flows that cannot be seen or otherwise detected by the naked eye. Translating the results of fluid dynamic models into predictions about flight and road mortality is more challenging and is currently under researched. However, the monarch's small size and low flight speed makes it reasonable to speculate that its movements will be strongly influenced by air flow patterns - especially under strong wind conditions.

The CFD models could be used to evaluate the transportation factors (volumes, speed, local topology) present at (observed) roadkill hotspots. For example, previous fall monarch roadkill surveys in Texas have identified two regions with relatively high roadkill (i.e., roadkill hotspots). The Point Comfort /Corpus Christi Causeways Monarch Roadkill Hotspot Region includes causeways from Lavaca Bay to Corpus Christi Bay in the Coastal Funnel. The Lavaca Bay topology consists essentially of a lagoon sheltered by barrier islands with a raised causeway that crosses it. For the most of its length the causeway is raised approximately 5-10 feet above water level and has an approximately 36-inch high railing type traffic barrier on each side. As such, the road is similar in design to the profile used in the CFD model presented in Fig. B.2. (except the presence of railing rather than solid concrete traffic barriers). Speculatively, laminar, stratified wind conditions over calm, inland waterbodies may cause monarchs low altitude flight that increase the interaction between monarchs and the critical elevations of roadway (the vertical traffic zone). Changes in air flow over such structures may also contribute to roadkill.

## APPENDIX C. MODELLING THE EFFICACY OF MONARCH MITIGATION ACTIVITIES FOR IMPROVING NET MONARCH POPULATION RECOVERY

The CCAA includes methods to monitor the effectiveness of management actions undertaken to conserve or restore monarch habitat. However, the long-term recovery of the eastern monarch population depends on activities and contingencies that occur beyond the state of Texas.

Models or heuristics that (more explicitly) translate the effects of Texas management actions to the recovery of the continental population may have considerable value for a variety of TxDOT stakeholders. For example, such models could be used for outreach, communications, and to aid planning consultations. At an operational level, detailed and accurate conservation success metrics could be useful for ensuring management activities are followed diligently.

TxDOT and their stakeholders could benefit from a conceptual model for objectively determining the amount of compensatory management required to offset (compensate for) monarch roadkill. The conceptual model relies on the following information:

- 1) Information on the amount of monarch roadkill that occurs in a defined region.
- 2) Information on the cost and reliability of improving or expanding monarch habitat. Because monarch populations are spatially and temporally variable, this should be measured using spatial and temporal metrics on the abundance, quality, and availability (space and time) of milkweed or floral nectar resources.
- 3) Information on the effect of habitat modifications on the survival, fecundity and development of monarchs of all life-stages that directly use a specified habitat (defined by resource availability).
- 4) Estimates of the (ecological or conservation) value of a unit increase (or decrease) of a monarch individual depending on its geographical and temporal origin.

Item 1 is the primary focus of this research project. The research team have also undertaken and published previous research in this area.

Items 2 and 3 in this list are covered by the existing monarch CCAA. Additionally, existing research (some of which has been performed by the research team) provides Texas specific models and tools that are useful for refining management (and estimates of the cost and reliability of such management will be an additional focus of the current research project).

Item 4 in the list alludes to both the complexity of eastern monarch population dynamics, and to the principal (target) unit of conservation (i.e., the sustainability of the migratory eastern monarch population and its migratory pathways).

A simple, practical and plausible metric of conservation success would be to compare the unit increase in monarch individuals as a result of conservation management to the number of individuals lost through roadkill. In this case successful mitigation would occur if the increase in monarchs directly offsets roadkill. However, given the complexity of eastern monarch population dynamics, the simple assumption of assigning a unit conservation value to each additional monarch produced through habitat restoration, may not represent the most accurate way of determining the true value of conserved or improved habitats. Consider the following arguments for the relative conservation importance of monarchs at different stages in the inter-continental migration:

- By definition, fall roadkill in Texas result in a loss of individuals that are closer to overwintering grounds than in any other U.S. state, and that have already overcome (or have not experienced) many of the threats associated with long distance migration (mortality due to unavailability of nectar resources, roadkill, or from other sources).
- Texas' northern migratory population (the overwintering generation and the first generation of migrants) are the foundations of subsequent (exponential) population growth that occurs with range expansion. As such, increased survival, development, and fecundity of these 'founding' populations could have a disproportionate effect on the peak population's size (mid-summer) in northern states, and therefore result in concomitant increases in the number of individuals migrating through Texas in the subsequent fall months.

These counter arguments illustrate the potential importance of assigning an appropriate ecological or conservation value to monarch individuals at various stages within the inter-continental population.

## APPENDIX D. MONARCH CROSSING SEASONAL WARNING SIGNS WITH ADVISORY SPEED REDUCTION

Efforts to reduce vehicle speed could increase rather than decrease monarch vehicle collisions since slower moving vehicles can lead to longer exposure of monarchs to the hazard of vehicle collision per unit area (Appendix A). Additional factors needing further study for their effects on flying monarchs, include how wind vortex currents created by vehicles of different sizes, shapes, and speeds impact monarch vehicle collisions (see Appendix A). Consequently, it is unclear whether monarchs can gain any advantage in avoiding vehicle collisions with minor reductions of speed, such as from 80 to 65 mph, which is in contrast to benefits from lower speeds in reducing roadkill for larger vertebrates (see Chapters 7.2.1 and 7.2.2).

In the event field investigations might be planned to assess vehicle speed impacts on monarch collisions, this appendix provides designs for deployment of monarch crossing warning signs that could be evaluated for two week periods in coordination with deployment of monarch flight diverters (Chapter 8). The general sign design comprises a single roadside warning sign assembly, with an estimated price of \$3,842.95 (TAPCO quote of 5/28/2019) (Fig. E.1). The signage consists of a monarch crossing blinkersign with a monarch butterfly pictogram (Fig. E.2A) that is patterned after non-vehicular warning signs, such as the deer crossing sign (W11-3) (Fig. E.2B) (TxDOT 2014c, 2021). The blinkersign is accompanied by a supplemental distance warning plaque advising a non-specific speed reduction for 3 mi (Fig. E.2C), which is patterned after the warning storage space sign (W10-11b) (Fig. E.2D) (TxDOT 2014c, 2021). The blinkersign is powered by a standard solar panel assembly installed with a frangible pedestal for breakaway on vehicle collision (Fig. E.3) (TxDOT 2003). The warning signage assembly would be placed 0.6 mi (1 km) up road from the first monarch flight diverter installation (Figs. E.1, E.4-5).

For evaluation of effects of warning signage on vehicle speed reduction, three portable vehicle counters could be operated for the two implementation weeks at each site, each counter separated by 3 km (1.9 mi). The first counter would be located 2 km (1.2 mi) up road from the monarch crossing blinkersign (which is 1 km, or 0.6 mi, up road from the diverter fence). The second counter would be located 3 km down road at the start of the first diverter fence installation (Figs. 8.2-8.3). A third counter would be placed 3 km down road from the second counter, which is 4 km (2.5 mi) down road from the monarch crossing blinker sign.

The monarch crossing warning signs could only be uncovered and powered on Mondays, Wednesdays, and Fridays with Tuesdays and Thursdays serving as control periods when warning signs are covered and unpowered. Daily average traffic would be



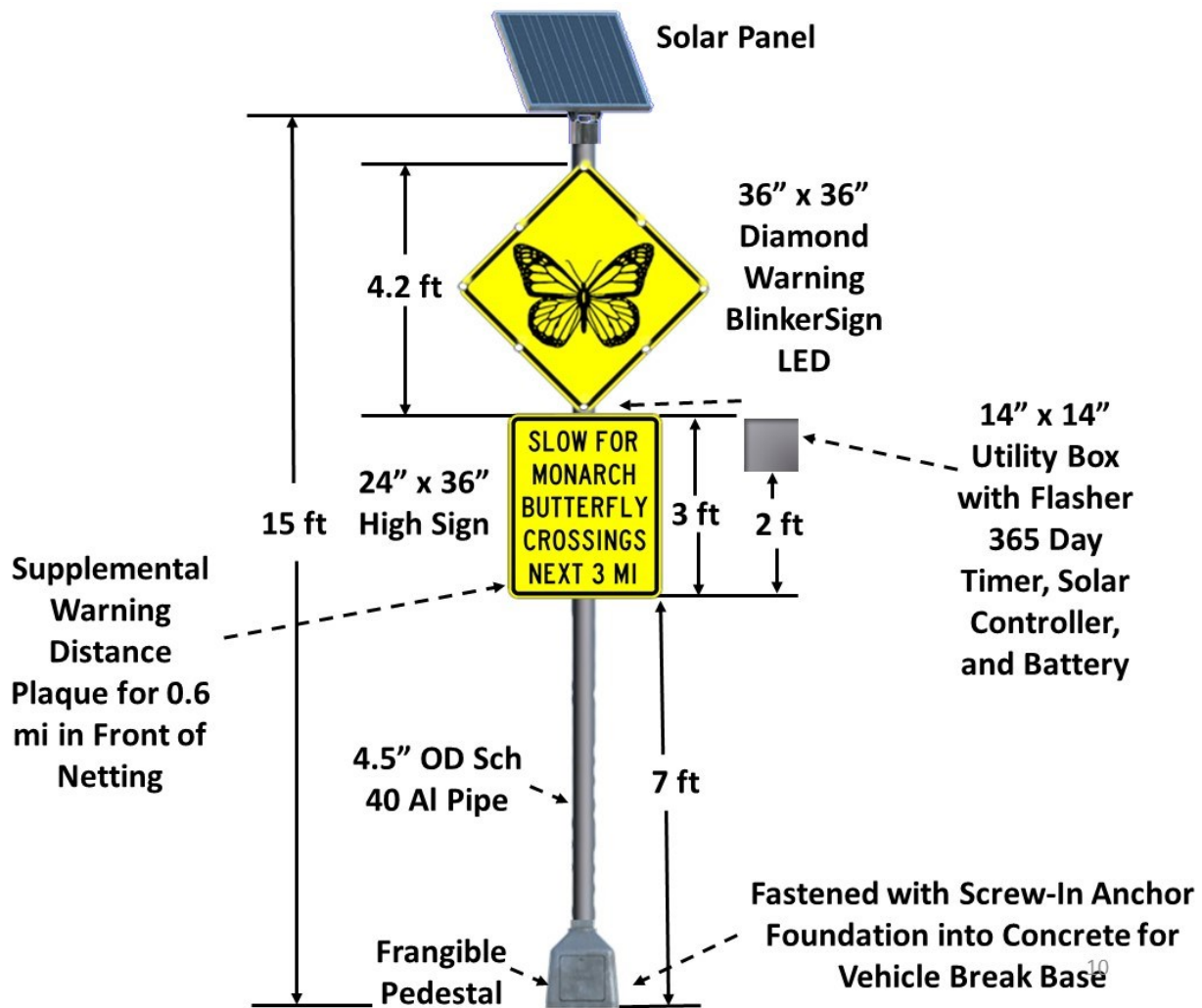
tallied on each counter to assess potential reductions in average vehicle speed at the second and third counters down road from the first counter for treatment days (Monday, Wednesday, and Friday) compared to non-treatment days (Tuesday and Thursday), when the monarch crossing blinkersign is covered and powered off. Daily monarch roadkill could then be compared between days when signs are uncovered and covered to assess potential differences in daily roadkill.



**Fig. D.1. Design concept for land-based installation of monarch crossing blinkersign with supplemental warning non-specific advisory speed reduction at Howard Draw Specialized Management Area #MP01.**



Figure D.2. Sign designs for (A) monarch crossing blinkersign; (B) deer crossing warning sign (W11-3) (TxDOT 2014c); (C) supplemental warning distance plaque with advisory non-specific speed reduction; and (D) warning storage space sign (W10-11b) (TxDOT 2014c).



**Figure D.3. Design and installation for solar power assembly monarch crossing blinkersign and supplemental warning distance plaque with advisory non-specific speed reduction (installation specifications from TxDOT 2003).**



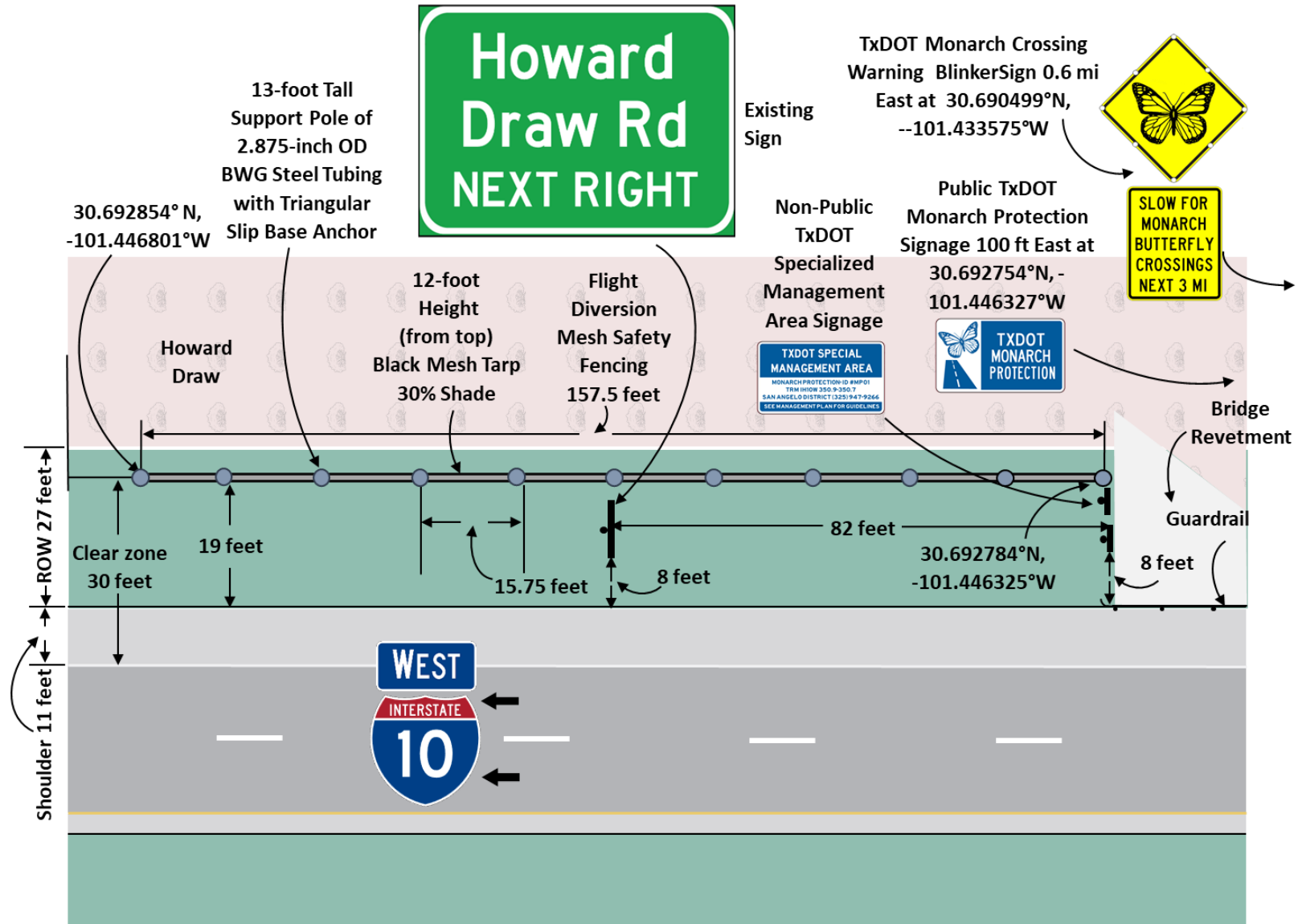


Figure D.4. Design concept for land-based installation of 157.5 ft sections of 12 ft height flight diversion mesh tarp with seasonal monarch crossing blinkersign at Howard Draw Specialized Management Area #MP01.

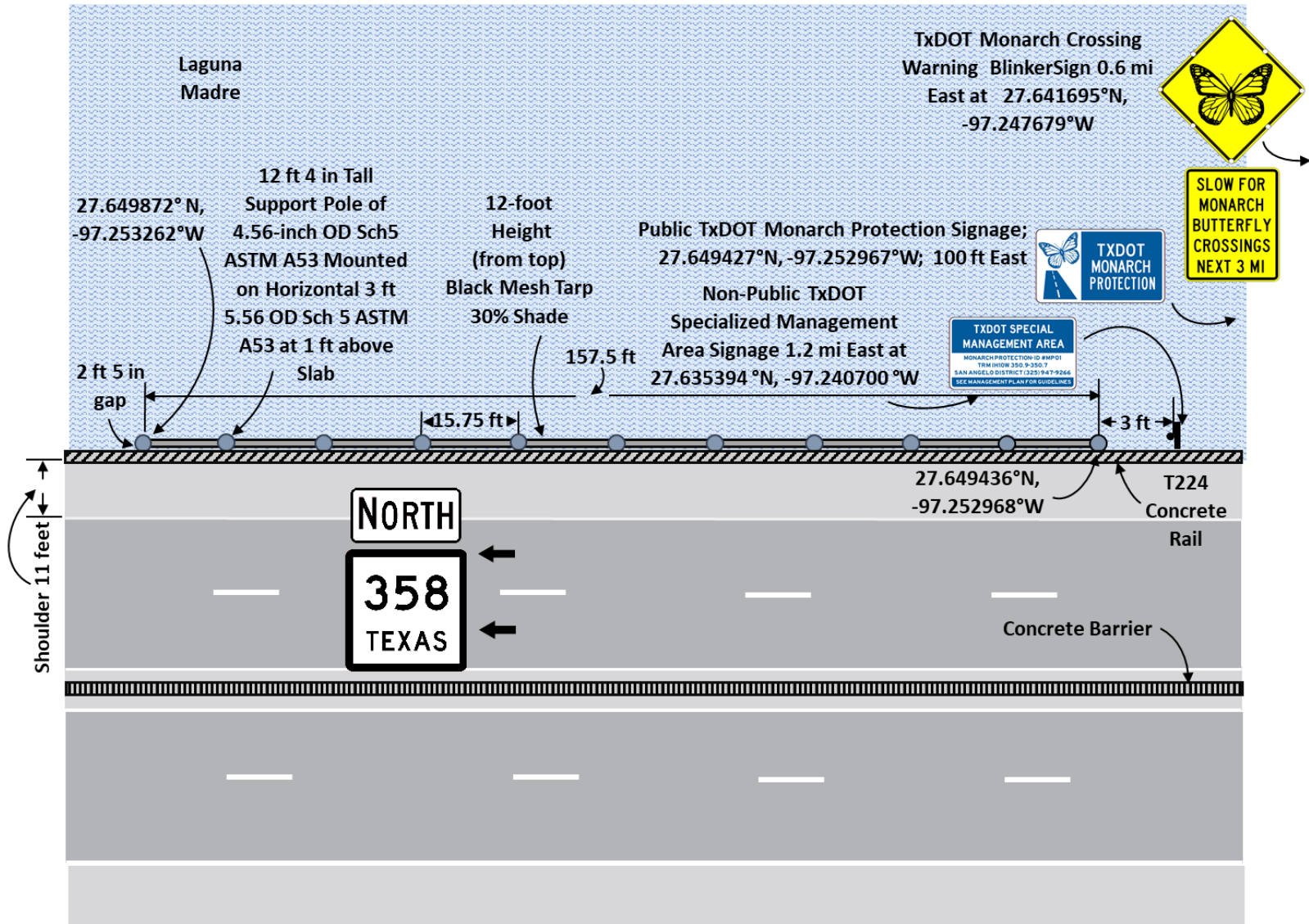


Figure D.5. Design concept for over-water installation of 157.5 ft sections of 12 ft height flight diversion mesh tarp with seasonal monarch crossing blinkersign at the John F. Kennedy Causeway Specialized Management Area #MP05.



## APPENDIX E. LOCATIONS OF SPECIALIZED MANAGEMENT AREAS FOR DIRECT AND INDIRECT ROADKILL MITIGATION

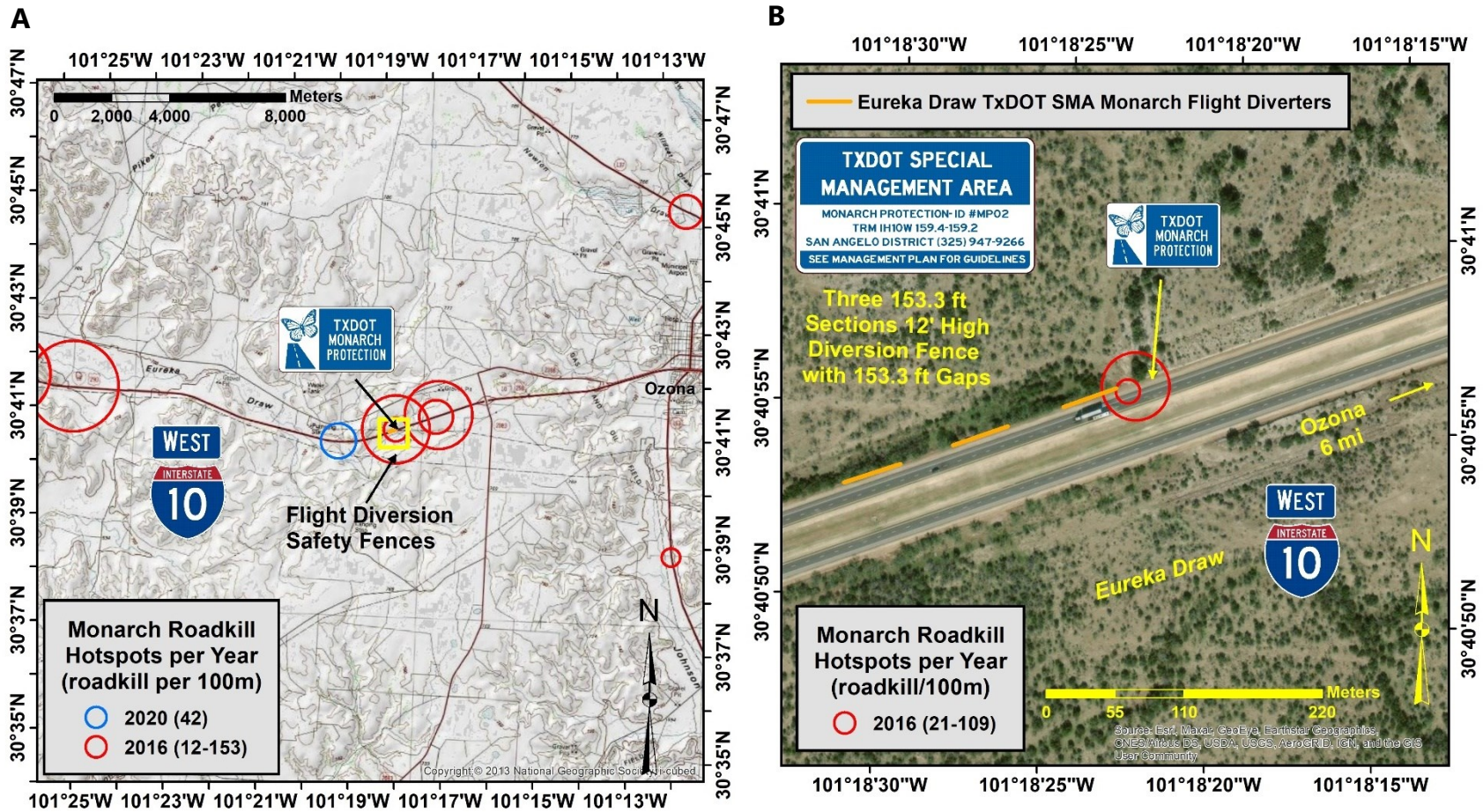
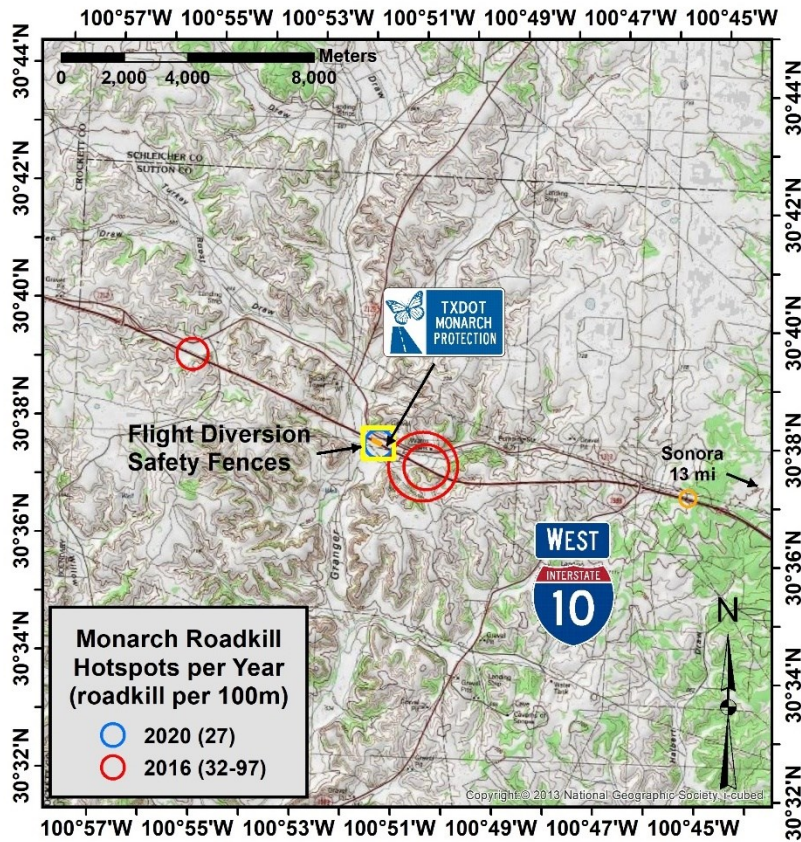


Figure E.1. Small scale (A) and large scale (B) maps for locations of TxDOT monarch protection signage and 153.3 ft sections of 12 ft height flight diversion tarp at Eureka Draw Specialized Management Area (SMA) #MP02 (see Fig. 8.5 for location maps of SMA #MP01).



A



B

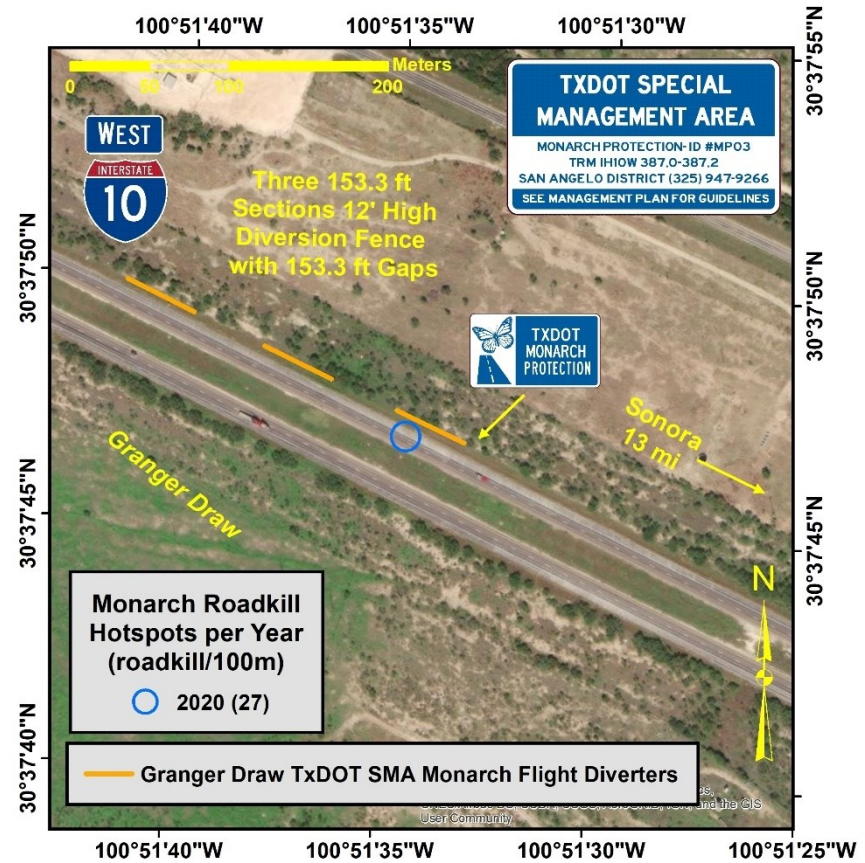


Figure E.2 Small scale (A) and large scale (B) maps for locations of TxDOT monarch protection signage and 153.3 ft sections of 12 ft height flight diversion tarp at Granger Draw Specialized Management Area #MP03.



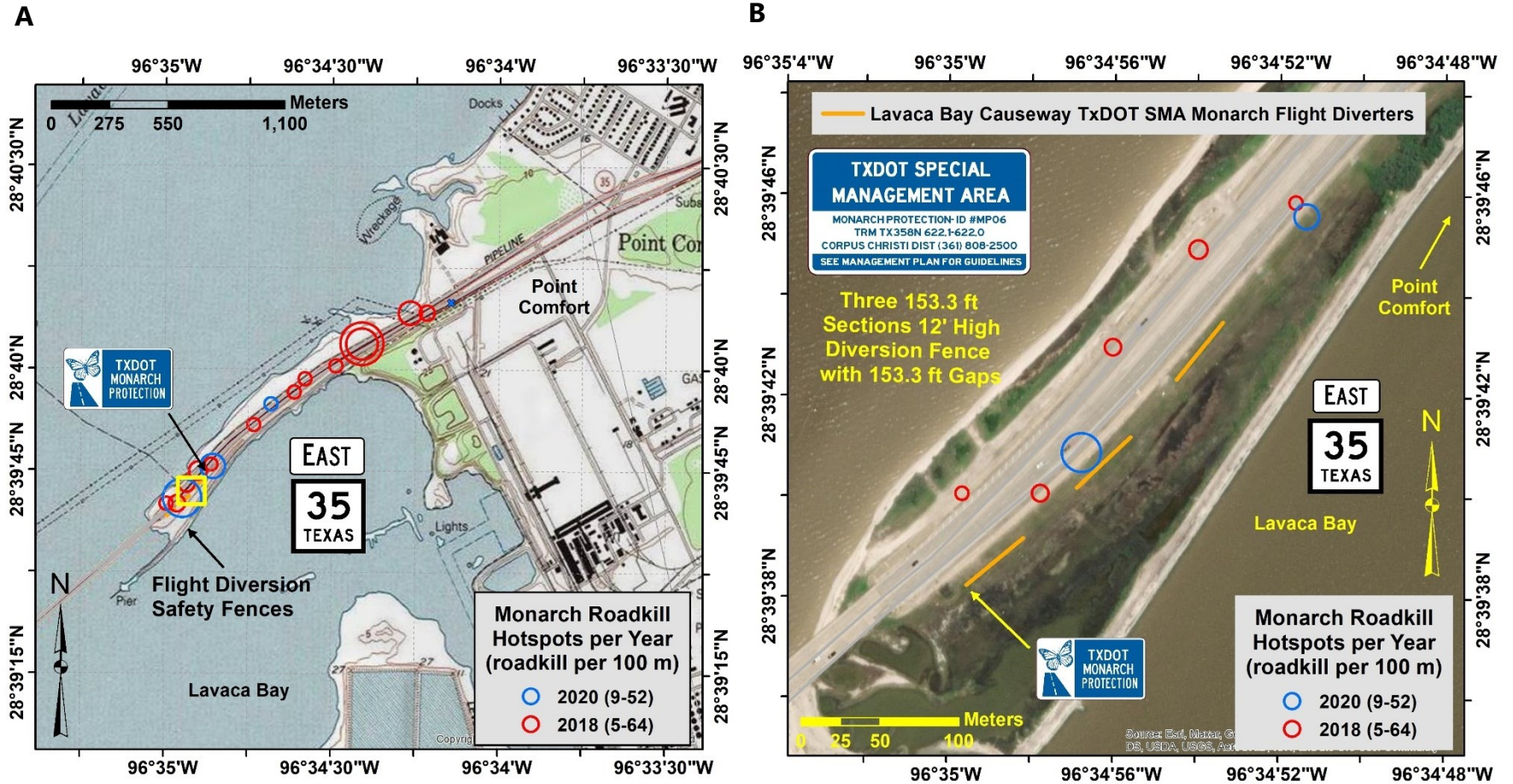


Figure E.3. Small scale (A) and large scale (B) maps for locations of TxDOT monarch protection signage and 153.3 ft sections of 12 ft height flight diversion tarp at Lavaca Bay Causeway Specialized Management Area #MP04.





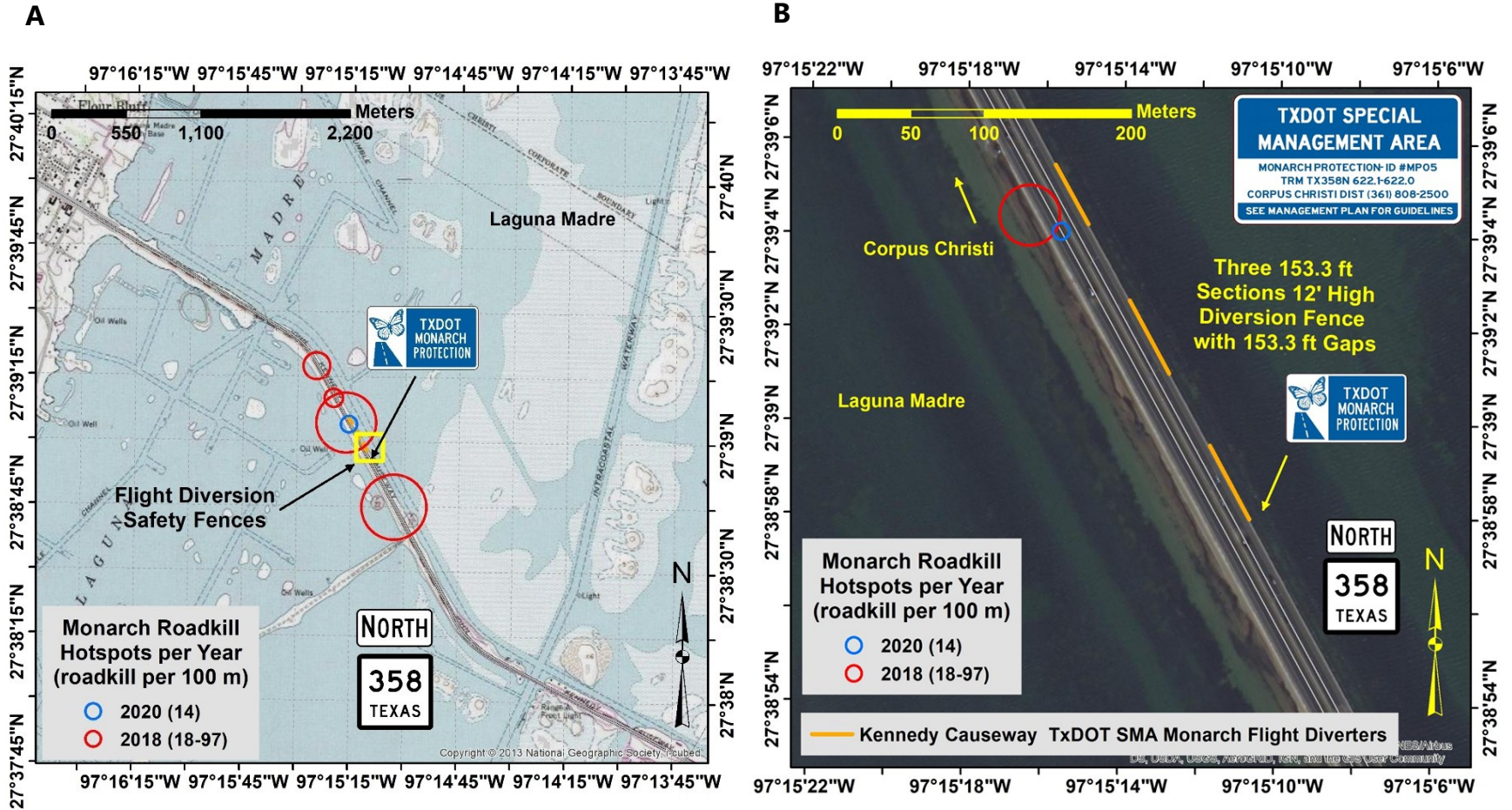


Figure E.5. Small scale (A) and large scale (B) maps for locations of TxDOT monarch protection signage and 153.3 ft sections of 12 ft height flight diversion tarp at John F. Kennedy Causeway Specialized Management Area #MP06.

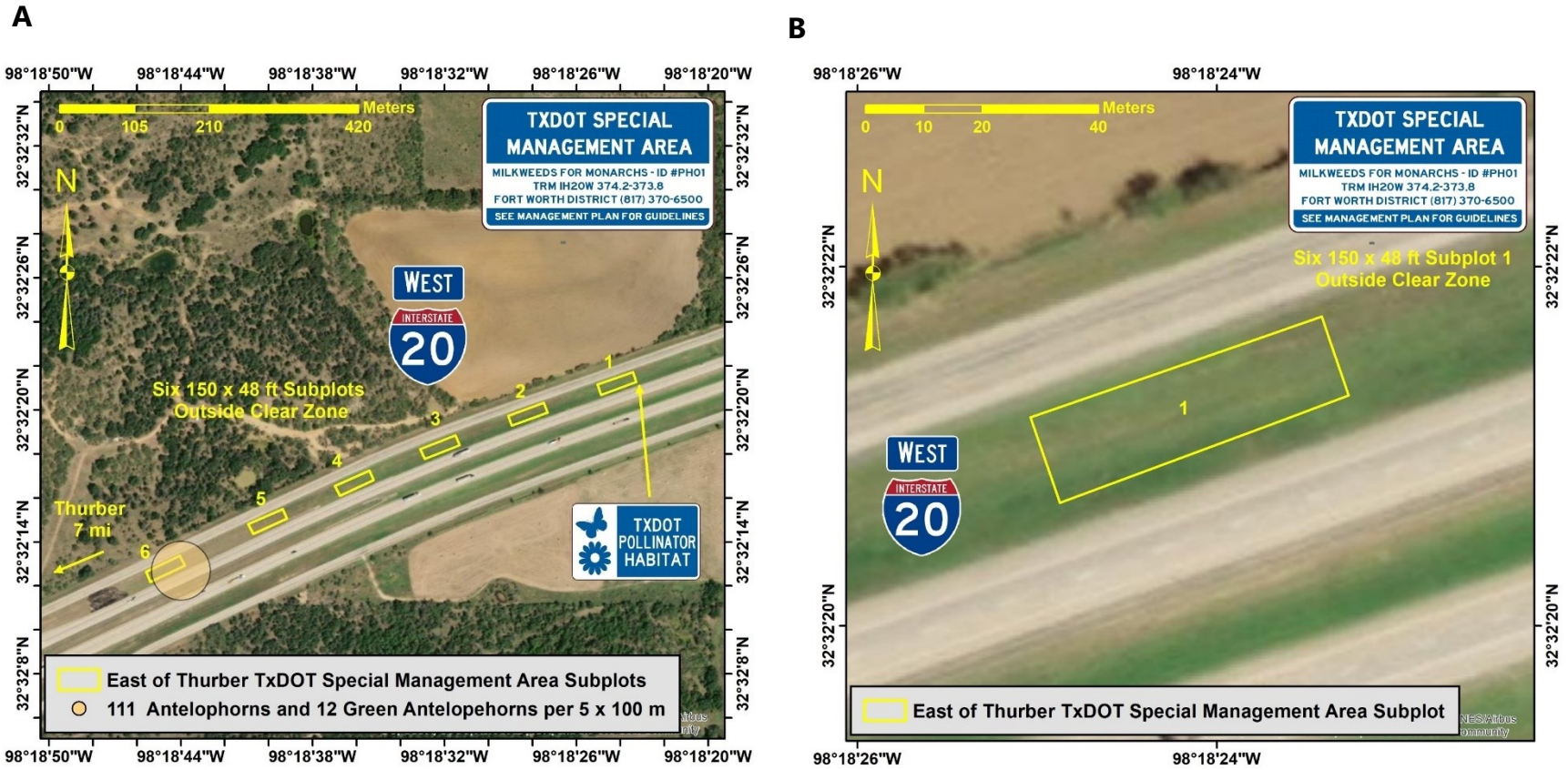


Figure E.6. Small scale (A) and large scale (B) maps for locations of TxDOT pollinator habitat signage and 150 ft x 48 ft plots for the east of Thurber Specialized Management Area #PH01 (Note: Only three of six plots shown to be selected).



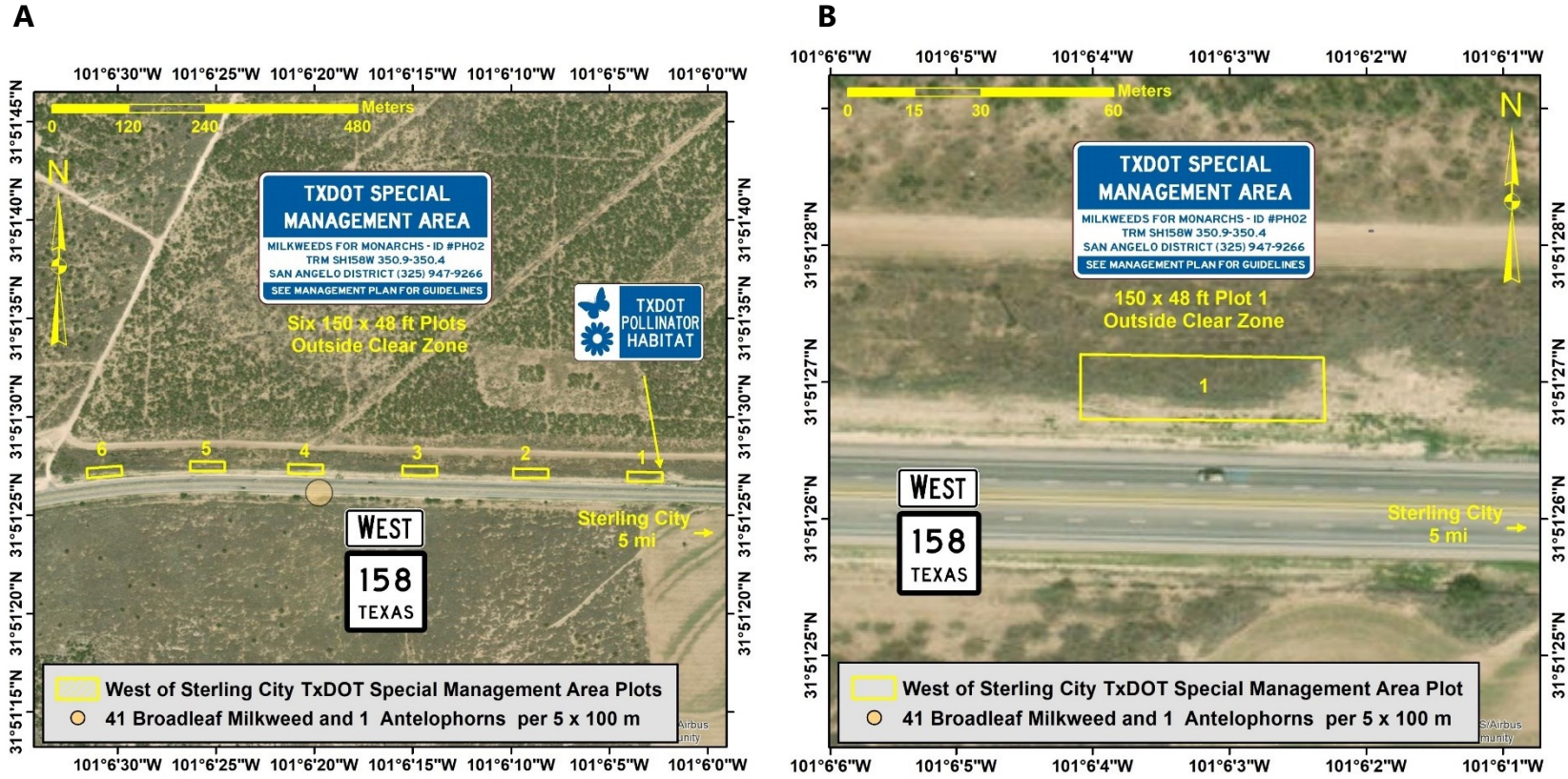


Figure E.7. Small scale (A) and large scale (B) maps for locations of TxDOT pollinator habitat signage and 150 ft x 48 ft plots for the west of Sterling Specialized Management Area #PH02 (Note: Only three of six plots shown to be selected).

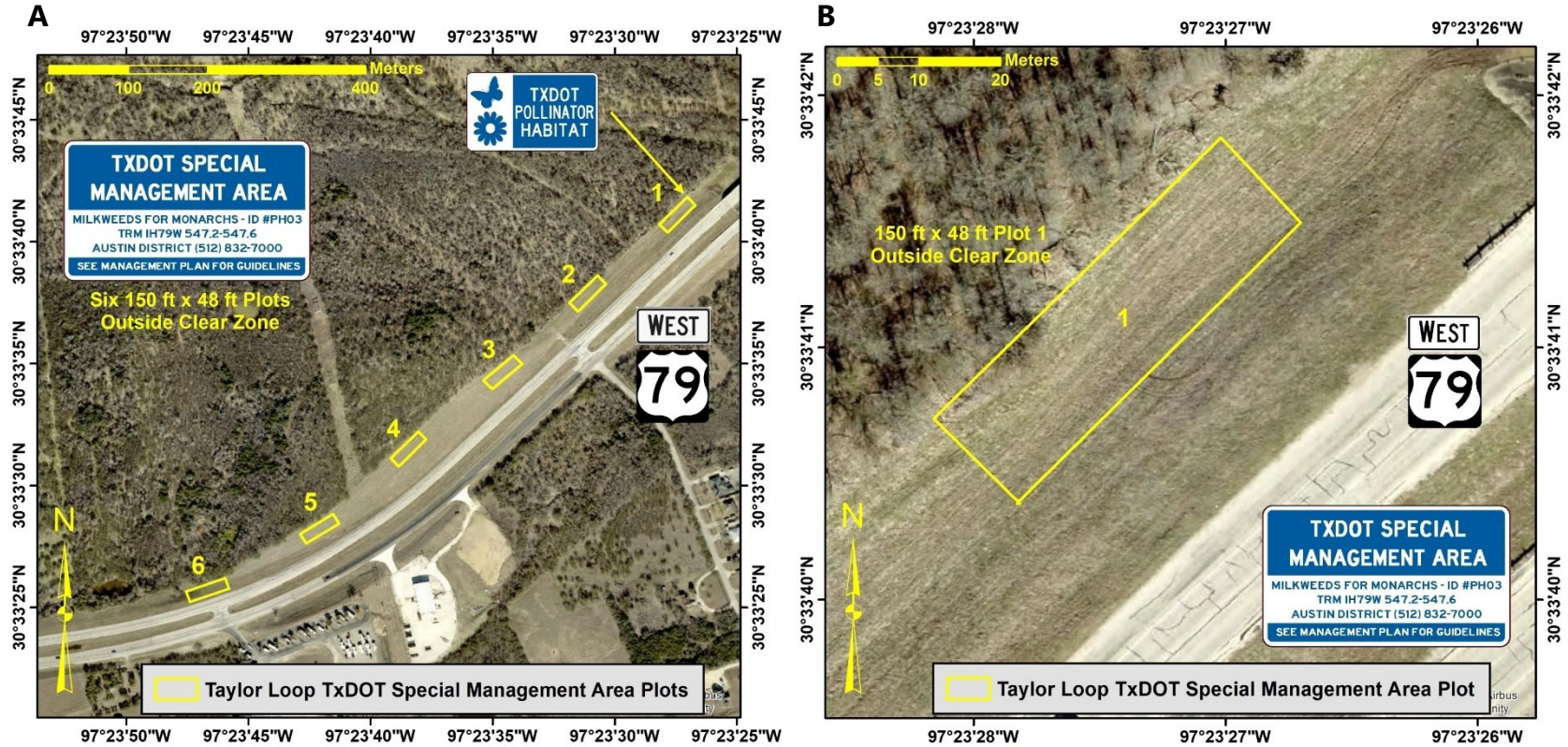


Figure E.8. Small scale (A) and large scale (B) maps for locations of TxDOT pollinator habitat signage and 150 ft x 48 ft plots for the Taylor loop Specialized Management Area #PH03 (Note: Only three of six plots shown to be selected).



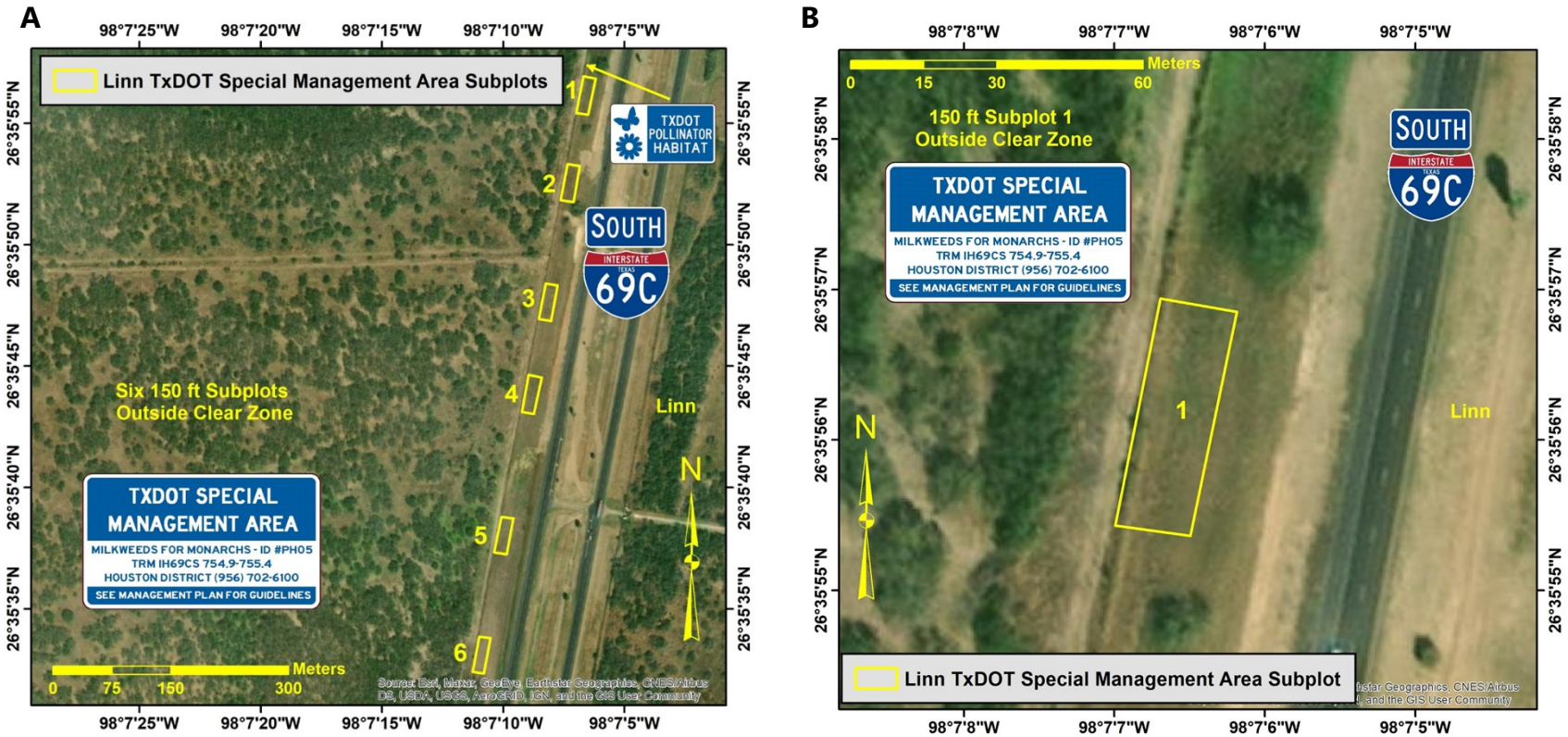


Figure E.9. Small scale (A) and large scale (B) maps for locations of TxDOT pollinator habitat signage and 150 ft x 48 ft plots for the Linn Specialized Management Area #PH05 (see Fig. 9.7 for location maps of SMA #PH04) (Note: Only three of six plots shown to be selected).

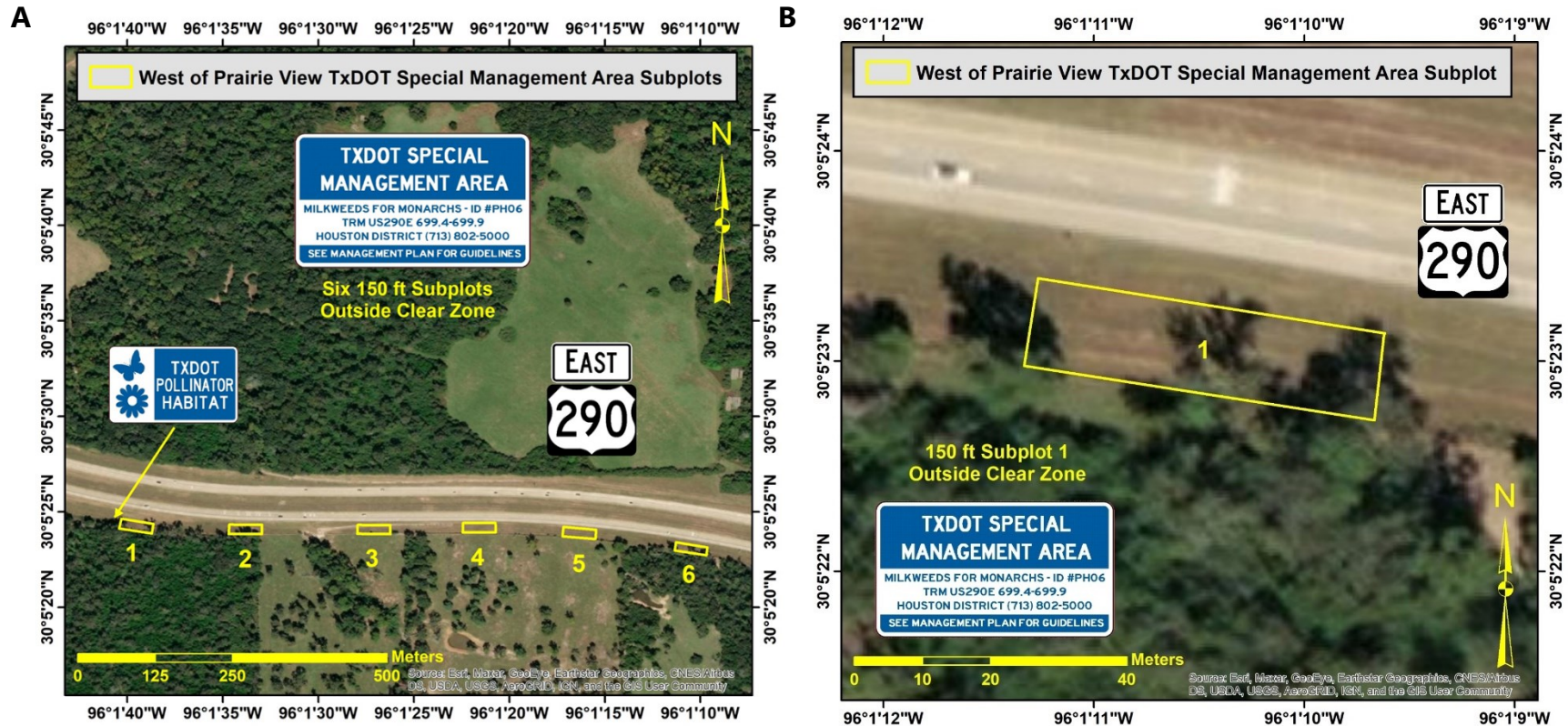


Figure E.10. Small scale (A) and large scale (B) maps for locations of TxDOT pollinator habitat signage and 150 ft x 48 ft plots for the west of Prairie View Specialized Management Area #PH06 (Note: Only three of six plots shown to be selected).



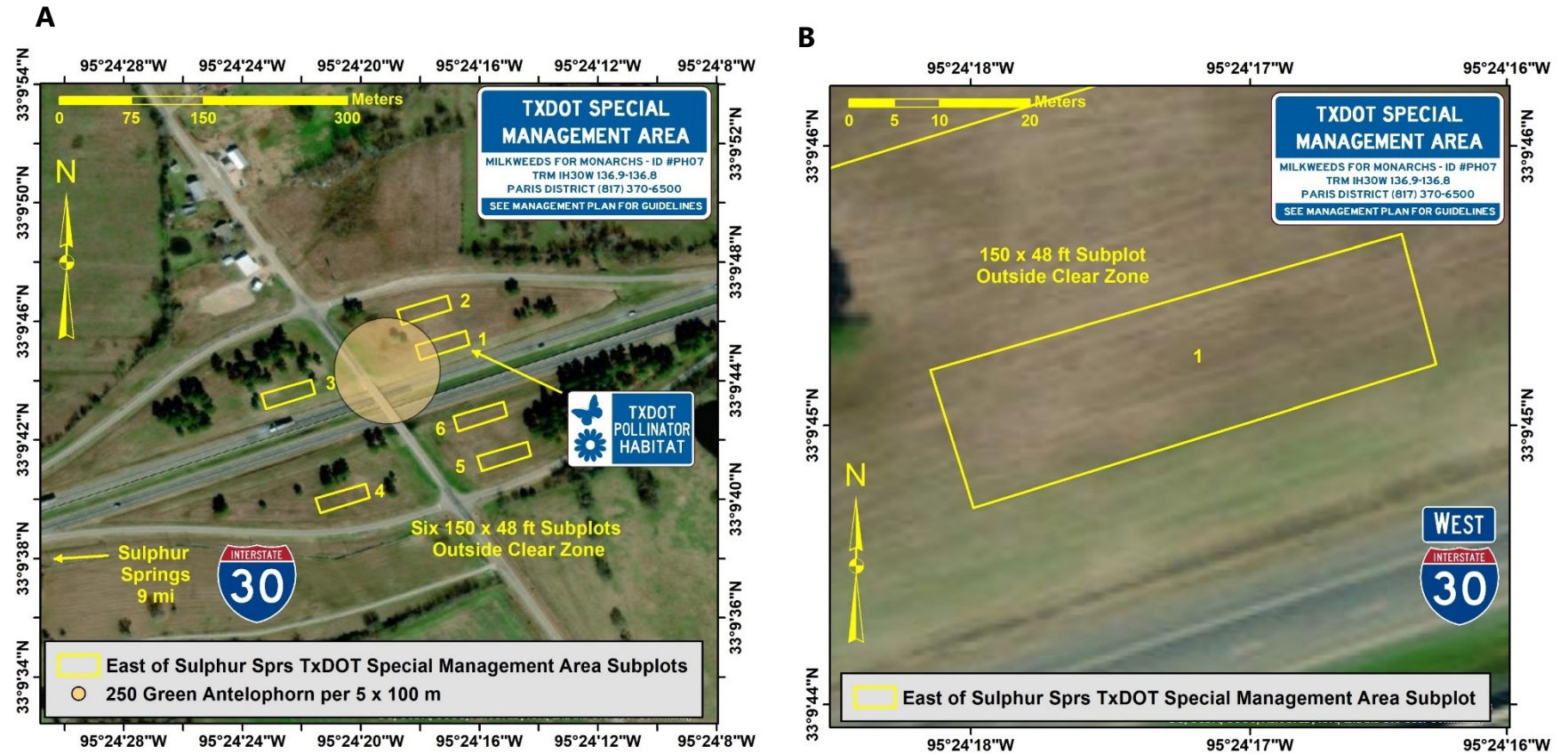


Figure E.11. Small scale (A) and large scale (B) maps for locations of TxDOT pollinator habitat signage and 150 ft x 48 ft plots for the east of Sulphur Springs Specialized Management Area #PH07 (Note: Only three of six plots shown to be selected).

## APPENDIX F. COST ESTIMATES FOR MATERIALS AND LABOR FOR INSTALLATION OF ROADSIDE MONARCH FLIGHT DIVERTER NETTING AND ROADSIDE POLLINATOR HABITAT

**Table F.1. Monarch flight diverter netting materials and costs for two-tarp comparison prototype.**

Item	Structure Unit Type	Unit	Units Needed	Unit Price	Sales Units	Sales Unit Price	Sales Units Needed	Shipping	Sales Tax	Total Price	Source
<i>Flight Diverter Netting and Supports – Prototype Testing of two Tarp Types</i>											
Mesh Tarp											
12' x 16' High Density Polyethylene Black Mesh Tarp 30% Shade with Taped Hems and Grommets Every 2'	12' x 16' Tarp (Actual size about 11.77' x 15.75')	1	10 x 3 per site x 5 sites = 150 + 1 prototype = 151	\$69.00	1	\$69.00	1	\$20.33		\$89.33	<a href="https://www.greenhousemega.com/30-percent-black-shade-cloth">https://www.greenhousemega.com/30-percent-black-shade-cloth</a>

**Table F.1. Monarch flight diverter netting materials and costs for two-tarp comparison prototype.**

Item	Structure Unit Type	Unit	Units Needed	Unit Price	Sales Units	Sales Unit Price	Sales Units Needed	Shipping	Sales Tax	Total Price	Source
12' x 16' Vinyl Coated Orange Mesh Tarp 50% Shade with Web Reinforced Taped Hems and Grommets Every 2'	12' x 16' Tarp (Actual size about 11.77' x 15.75')	1	1	\$168.00	1	\$168.00	1	\$24		\$192.00	<a href="https://www.tarpsonline.com/tarps/vinylmesh.aspx">https://www.tarpsonline.com/tarps/vinylmesh.aspx</a>
Subtotal										\$281	
Posts and Anchors											
14' ht 2.875" (2 7/8") OD 10 BWG Steel Tubing	1	1	3	\$127.00	1	\$127.00	3			\$381.00	Estimate from: <a href="https://ftp.dot.state.tx.us/pub/txdot-info/cmd/cserve/distinfo/cisrpts/637692001.pdf">https://ftp.dot.state.tx.us/pub/txdot-info/cmd/cserve/distinfo/cisrpts/637692001.pdf</a>
Triangular Slip Base Top Post Receiver, Round Tube	1	1	3	\$154.70	1	\$154.70	3			\$464.10	Estimate from: <a href="http://legacy.elpasotexas.gov/purchasing/docs/2020-716%20Transit%20System%20Site%20Improvements.pdf">http://legacy.elpasotexas.gov/purchasing/docs/2020-716%20Transit%20System%20Site%20Improvements.pdf</a>

**Table F.1. Monarch flight diverter netting materials and costs for two-tarp comparison prototype.**

Item	Structure Unit Type	Unit	Units Needed	Unit Price	Sales Units	Sales Unit Price	Sales Units Needed	Shipping	Sales Tax	Total Price	Source
Triangular Slip Base Bottom Anchor for Vehicle Break, 10" Stub Depth	1	1	3	\$178.50	1	\$178.50	3			\$535.50	Estimate from: <a href="http://legacy.elpasotexas.gov/purchasing/docs/2020-716%20Transit%20System%20Site%20Improvements.pdf">http://legacy.elpasotexas.gov/purchasing/docs/2020-716%20Transit%20System%20Site%20Improvements.pdf</a>
Triangular Slip Base Match Plate Hardware Kit	1	1	3	\$47.60	1	\$47.60	3			\$142.80	Estimate from: <a href="http://legacy.elpasotexas.gov/purchasing/docs/2020-716%20Transit%20System%20Site%20Improvements.pdf">http://legacy.elpasotexas.gov/purchasing/docs/2020-716%20Transit%20System%20Site%20Improvements.pdf</a>
Class "A" Concrete (3,500 psi) (TxDOT Item 04206133)	2.5 Cubic Ft per Post Hole	1 cu yard (27 cu ft)	(2.5 x 3)/27 = 0.278 cu yd	\$310/cu yd	1 cu yd	\$310	0.278			\$86.18	TxDOT: <a href="https://ftp.dot.state.tx.us/pub/txdot/cst/average-low-bid/hwy-construction/ALB-C.xlsm">https://ftp.dot.state.tx.us/pub/txdot/cst/average-low-bid/hwy-construction/ALB-C.xlsm</a>
Subtotal										\$1,609.58	
Tarp Support											



**Table F.1. Monarch flight diverter netting materials and costs for two-tarp comparison prototype.**

Item	Structure Unit Type	Unit	Units Needed	Unit Price	Sales Units	Sales Unit Price	Sales Units Needed	Shipping	Sales Tax	Total Price	Source
Eye Top Loop Cap for 2 7/8" OD Post with 1 5/8" Top Rail	1	1	3	\$3.87	1	\$3.87	3	\$11.73	\$0.96	\$24.30	<a href="https://fencesupplyinc.com/product/line-top-steel-2-7-8-inch-x-1-5-8-inch/">https://fencesupplyinc.com/product/line-top-steel-2-7-8-inch-x-1-5-8-inch/</a>
6.5' Sections of	1	1	5	\$27.29	1	\$27.29	5		\$11.26	\$147.71	<a href="https://www.mccoys.com/shop/6-6-x-1-58-chain-link-fence-line-post-18-gauge049/p.060803">https://www.mccoys.com/shop/6-6-x-1-58-chain-link-fence-line-post-18-gauge049/p.060803</a>
1 5/8" OD top rail, 18 Gauge											
Galvanized Connector Sleeve for 1 5/8" Top Rail Sections	1	1	4	\$2.49	1	\$2.49	4	\$11.75	\$0.82	\$22.53	<a href="https://fencesupplyinc.com/product/1-5-8-inch-sleeve-galvanized/">https://fencesupplyinc.com/product/1-5-8-inch-sleeve-galvanized/</a>

**Table F.1. Monarch flight diverter netting materials and costs for two-tarp comparison prototype.**

Item	Structure Unit Type	Unit	Units Needed	Unit Price	Sales Units	Sales Unit Price	Sales Units Needed	Shipping	Sales Tax	Total Price	Source
Dome Cap, 1 5/8" Aluminum	1	1	2	\$0.79	1	\$0.79	2	\$11.71	\$0.13	\$13.42	<a href="https://fencesupplyinc.com/product/dome-cap-1-5-8-inch-aluminum/">https://fencesupplyinc.com/product/dome-cap-1-5-8-inch-aluminum/</a>
15" x 0.317" 350 lbs Tensile Strength Stainless Steel Cable Ties	100 Zip Ties	Pkg 100	23 ties per Tarp x 2 Tarps = 46 ties = 1 Pkg	\$28.55	1	\$28.55	1	\$11.21	\$3.18	\$42.94	<a href="https://www.cabletiesandmore.com/stainless-steel-cable-ties?pid=58">https://www.cabletiesandmore.com/stainless-steel-cable-ties?pid=58</a>
ASTM D4956 Type 1 Orange Reflective Tape 12" x 9.1" Strips	12" x 30' roll (= 39 12" x 9.1" strips)	Roll	(9.1" x 3)/360" = 0.075 roll	\$119.99	1	\$119.99	0.075			\$9.00	<a href="https://shop.reflectivestore.com/12-x-30-Reflective-Tape-Roll-11999-12-30-reflective.htm">https://shop.reflectivestore.com/12-x-30-Reflective-Tape-Roll-11999-12-30-reflective.htm</a>
Subtotal										\$259.90	
<i>Labor</i>											

**Table F.1. Monarch flight diverter netting materials and costs for two-tarp comparison prototype.**

Item	Structure Unit Type	Unit	Units Needed	Unit Price	Sales Units	Sales Unit Price	Sales Units Needed	Shipping	Sales Tax	Total Price	Source
Triangular Slip Base 3" x 3' Stud (Bottom Anchor) Installation	1	1	3	\$196.35	1	\$196.35	3			\$589.05	Estimate from: <a href="http://legacy.elpasotexas.gov/purchasing/docs/2020-716%20Transit%20System%20Site%20Improvements.pdf">http://legacy.elpasotexas.gov/purchasing/docs/2020-716%20Transit%20System%20Site%20Improvements.pdf</a>
12' x 16' Tarp and Support Pole Installation	1/2 hr per tarp	1 hr	33 x 0.5 = 16.5	\$40.00 /hr (2 people)	1 hr	\$40	2			\$80.00	Estimate 30 minutes per tarp at \$40/hr
12' x 16' Tarp and Support Pole Removal	1/2 hr per tarp	1 hr	33 x 0.5 = 16.5	\$40.00 /hr (2 people)	1 hr	\$40	2			\$80.00	Estimate 30 minutes per tarp at \$40/hr
TOTAL Labor										\$749.05	
TOTAL Materials										\$2,150.81	
GRAND TOTAL										\$2,899.86	

**Table F.2. Monarch flight diverter netting materials and costs for five land-based testing sites.**

Item	Structure Unit Type	Unit	Units Needed	Unit Price	Sales Units	Sales Unit Price	Sales Units Needed	Shipping	Sales Tax	Total Price	Source
<i>Per Site Flight Diverter Netting and Supports – Implementation Testing with Three 157.75' Sections</i>											
<b>Mesh Tarp</b>											
12' x 16' High Density Polyethylene Black Mesh Tarp 30% Shade with Taped Hems and Grommets Every 2'	12' x 16' Tarp (Actual size about 11.77' x 15.75')	1	10 x 3 per site = 30	\$69.00	1	\$69.00	30	\$0.00		\$2,070.00	<a href="https://www.greenhousemegastore.com/30-percent-black-shade-cloth?returnurl=%2fsearch%3fq%3dshade%2bcloth">https://www.greenhousemegastore.com/30-percent-black-shade-cloth?returnurl=%2fsearch%3fq%3dshade%2bcloth</a>
<b>Posts and Anchors</b>											
14' ht 2.875" (2 7/8") OD 10 BWG Steel Tubing	1	1	11 x 3 per site = 33	\$127.00	1	\$127.00	33			\$4,191.00	Quote from Texas Corrugators (Fig. F.1) ( <a href="http://www.txcorr.com">http://www.txcorr.com</a> ) for 168 qty, 2/14/2022



**Table F.2. Monarch flight diverter netting materials and costs for five land-based testing sites.**

Item	Structure Unit Type	Unit	Units Needed	Unit Price	Sales Units	Sales Unit Price	Sales Units Needed	Shipping	Sales Tax	Total Price	Source
Triangular Slip Base Casting with Keeper Plate and Bolts (Top Post Receiver)	1	1	11 x 3 per site = 33	\$42.00	1	\$42.00	33			\$1,386.00	Quote from Texas Corrugators (Fig. F.1) ( <a href="http://www.txcorr.com">http://www.txcorr.com</a> ) for 220 qty, 2/14/2022
Triangular Slip Base 3" x 3' Stub (Bottom Anchor)	1	1	11 x 3 per site = 33	\$77.00	1	\$77.00	33			\$2,541.00	Quote from Texas Corrugators (Fig. F.1) ( <a href="http://www.txcorr.com">http://www.txcorr.com</a> ) for 220 qty, 2/14/2022
Class "A" Concrete (3,500 psi) (TxDOT Item 04206133)	2.5 Cubic Ft per Post Hole	1 cu yard (27 cu ft)	(2.5 x 11 x 3)/27 = 3.06 cu yd	\$310/cu yd	1 cu yd	\$310	3.06			\$948.60	<a href="https://ftp.dot.state.tx.us/pub/txdot/cst/average-low-bid/hwy-construction/ALB-C.xlsm">TxDOT: https://ftp.dot.state.tx.us/pub/txdot/cst/average-low-bid/hwy-construction/ALB-C.xlsm</a>
Subtotal										\$9,066.60	
Tarp Support											

**Table F.2. Monarch flight diverter netting materials and costs for five land-based testing sites.**

Item	Structure Unit Type	Unit	Units Needed	Unit Price	Sales Units	Sales Unit Price	Sales Units Needed	Shipping	Sales Tax	Total Price	Source
Eye Top Loop Cap for 2 7/8" OD Post with 1 5/8" Top Rail	1	1	11 x 3 per site = 33	\$3.87	1	\$3.87	33	\$47.39	\$10.54	\$185.64	<a href="https://fencesupplyinc.com/product/line-top-steel-2-7-8-inch-x-1-5-8-inch/">https://fencesupplyinc.com/product/line-top-steel-2-7-8-inch-x-1-5-8-inch/</a>
6.5' Sections of 1 5/8" OD top rail, 18 Gauge	1	1	25 x 3 per site = 75	\$27.29	1	\$27.29	75	#####		\$2,215.61	<a href="https://www.mccoys.com/shop/6-6-x-1-58-chain-link-fence-line-post-18-gauge049/p.060803">https://www.mccoys.com/shop/6-6-x-1-58-chain-link-fence-line-post-18-gauge049/p.060803</a>
Galvanized Connector Sleeve for 1 5/8" Top Rail Sections	1	1	13 x 3 per site = 39	\$2.49	1	\$2.49	39	\$36.04	\$8.01	\$141.16	<a href="https://fencesupplyinc.com/product/1-5-8-inch-sleeve-galvanized/">https://fencesupplyinc.com/product/1-5-8-inch-sleeve-galvanized/</a>

**Table F.2. Monarch flight diverter netting materials and costs for five land-based testing sites.**

Item	Structure Unit Type	Unit	Units Needed	Unit Price	Sales Units	Sales Unit Price	Sales Units Needed	Shipping	Sales Tax	Total Price	Source
Dome Cap, 1 5/8" Aluminum	1	1	11 x 3 per site = 33	\$0.79	1	\$0.79	33	\$9.67	\$2.15	\$37.89	<a href="https://fencesupplyinc.com/product/dome-cap-1-5-8-inch-aluminum/">https://fencesupplyinc.com/product/dome-cap-1-5-8-inch-aluminum/</a>
15" x 0.317" 350 lbs Tensile Strength Stainless Steel Cable Ties	100 Zip Ties	Pkg 100	23 ties per Tarp x 10 Tarps x 3 per site = 690 = 7 Pkg	\$28.55	1	\$28.55	7	\$11.34	\$16.90	\$228.09	<a href="https://www.cabletiesandmore.com/stainless-steel-cable-ties?pid=58">https://www.cabletiesandmore.com/stainless-steel-cable-ties?pid=58</a>
ASTM D4956 Type 1 Orange Reflective Tape 12" x 9.1" Strips	12" x 30' roll (= 39 12" x 9.1" strips)	Roll	(9.1" x 33)/360" = 0.834 roll	\$119.99	1	\$119.99	0.834			\$100.07	<a href="https://shop.reflectivestore.com/12-x-30-Reflective-Tape-Roll-11999-12-30-reflective.htm">https://shop.reflectivestore.com/12-x-30-Reflective-Tape-Roll-11999-12-30-reflective.htm</a>
Subtotal										\$2,908.46	
<i>Signage for Flight Diverter Netting</i>											
10' ht 2.875" (2 7/8") OD 10 BWG Steel Tubing	1	1	2 per site	\$91.00	1	\$91.00	2			\$182.00	Quote from Texas Corrugators (Fig. F.1) ( <a href="http://www.txcorr.com">http://www.txcorr.com</a> ) for 45 qty, 2/14/2022

**Table F.2. Monarch flight diverter netting materials and costs for five land-based testing sites.**

Item	Structure Unit Type	Unit	Units Needed	Unit Price	Sales Units	Sales Unit Price	Sales Units Needed	Shipping	Sales Tax	Total Price	Source
Triangular Slip Base Casting with Keeper Plate and Bolts (Top Post Receiver)	1	1	2 per site	\$42.00	1	\$42.00	2			\$84.00	Quote from Texas Corrugators (Fig. F.1) ( <a href="http://www.txcorr.com">http://www.txcorr.com</a> ) for 220 qty, 2/14/2022
Triangular Slip Base 3" x 3' Stub (Bottom Anchor)	1	1	2 per site	\$77.00	1	\$77.00	2			\$154.00	Quote from Texas Corrugators (Fig. F.1) ( <a href="http://www.txcorr.com">http://www.txcorr.com</a> ) for 220 qty, 2/14/2022
42" x 24" Blue/White Public "TxDOT Monarch Protection" Sign	1	1	1 per site	\$71.03 (if 5)	1	\$71.03	1			\$71.03	<a href="https://www.signs.com/de-sign/?id=8ef224be-6d30-4616-8781-586058b7a788">https://www.signs.com/de-sign/?id=8ef224be-6d30-4616-8781-586058b7a788</a>



**Table F.2. Monarch flight diverter netting materials and costs for five land-based testing sites.**

Item	Structure Unit Type	Unit	Units Needed	Unit Price	Sales Units	Sales Unit Price	Sales Units Needed	Shipping	Sales Tax	Total Price	Source
42" x 24" Blue/White Non-Public "TxDOT Special Management Area Monarch Projection ID" Sign	1	1	1 per site	\$86.50	1	\$86.50	1			\$86.50	<a href="https://www.signs.com/design/?id=8ef224be-6d30-4616-8781-586058b7a788">https://www.signs.com/design/?id=8ef224be-6d30-4616-8781-586058b7a788</a>
U-Clamp Sign Hardware, 2.5"	1	1	2 x 2 signs per site = 4	\$3.39	4	\$3.39	4			\$13.56	Quote from Texas Corrugators (Fig. F.1) ( <a href="http://www.txcorr.com">http://www.txcorr.com</a> ) for 118 qty, 2/14/2022
Class "A" Concrete (3,500 psi) (TxDOT Item 04206133)	2.5 Cubic Ft per Post Hole	1 cu yard (27 cu ft)	(2.5 x 2)/27 = 0.185 cu yd	\$310/cu yd	1 cu yd	\$310	0.185			\$57.35	<a href="https://ftp.dot.state.tx.us/pub/txdot/cst/average-low-bid/hwy-construction/ALB-C-2.xlsm">https://ftp.dot.state.tx.us/pub/txdot/cst/average-low-bid/hwy-construction/ALB-C-2.xlsm</a>
Subtotal										\$648.44	
<i>Labor</i>											

**Table F.2. Monarch flight diverter netting materials and costs for five land-based testing sites.**

Item	Structure Unit Type	Unit	Units Needed	Unit Price	Sales Units	Sales Unit Price	Sales Units Needed	Shipping	Sales Tax	Total Price	Source
Triangular Slip Base 3" x 3' Stud (Bottom Anchor) Installation	1	1	33 Support Poles + 2 Signposts = 35	\$196.35	1	\$196.35	35			\$6,872.25	<a href="http://legacy.elpasotexas.gov/purchasing/docs/2020-716%20Transit%20System%20Site%20Improvements.pdf">Estimate from: http://legacy.elpasotexas.gov/purchasing/docs/2020-716%20Transit%20System%20Site%20Improvements.pdf</a>
12' x 16' Tarp and Support Pole Installation	1/2 hr per tarp	1 hr	33 x 0.5 = 16.5	\$40.00/hr (2 people)	1 hr	\$40	16.5			\$660.00	Estimate 30 minutes per tarp at \$40/hr
Sign Post Placement and Placard Installation	1/2 hr per sign	1 hr	2 x 0.5 = 1	\$40.00/hr (2 people)	1 hr	\$40	1			\$40.00	Estimate 30 minutes per sign at \$40/hr
12' x 16' Tarp and Support Pole Removal (after 2 weeks)	1/2 hr per tarp	1 hr	33 x 0.5 = 16.5	\$40.00/hr (2 people)	1 hr	\$40	16.5			\$660.00	Estimate 30 minutes per tarp at \$40/hr
<b>TOTAL Labor</b>										<b>\$8,232.25</b>	
<b>TOTAL Materials</b>										<b>\$14,693.50</b>	
<b>GRAND TOTAL per Site</b>										<b>\$22,925.75</b>	
<i>Costs per foot Diversion Net Materials and Installation</i>											

**Table F.2. Monarch flight diverter netting materials and costs for five land-based testing sites.**

Item	Structure Unit Type	Unit	Units Needed	Unit Price	Sales Units	Sales Unit Price	Sales Units Needed	Shipping	Sales Tax	Total Price	Source
Cost per 473.25 ft plus two Extra Posts (from having three separate fence sections)										\$22,925.75	
Subtract Materials and Installation of Two Extra Posts											
2 13' ht 2.875" (2 7/8") OD 10 BWG Steel Tubing										-\$254.00	
2 Triangular Slip Base Casting with Keeper Plate and Bolts (Top Post Receiver)										-\$84.00	
2 Triangular Slip Base 3" x 3' Stub (Bottom Anchor)										-\$154.00	
2 Class "A" Concrete (3,500 psi) (TxDOT Item 04206133)										-\$57.49	
2 Slip Base Bottom Anchor Installation Labor										-\$392.70	
<b>Subtotal Subtraction</b>										<b>-\$942.19</b>	
<b>Cost per 473.25 ft</b>										<b>\$21,983.56</b>	
<b>Cost per ft</b>		<b>473.5</b>								<b>\$46.43</b>	
<b>GRAND TOTAL per Five Sites</b>										<b>\$114,628.76</b>	
<b>Annual Maintenance per Site</b>											
<i>Materials</i>											
15" x 0.317" 350 lbs Tensile Strength Stainless Steel Cable Ties	cable tie	1	23 ties per Tarp x 10 Tarps x 3 per site = 690 = 7 Pkg	\$0.29	pk 100	\$28.55	7		\$11.34	\$16.90	\$228.09
<i>Labor</i>											
12' x 16' Tarp and Support Pole Installation	1/2 hr per tarp	1 hr	33 x 0.5 = 16.5	\$40.00/hr (2 people)	1 hr	\$40	16.5				\$660.00

**Table F.2. Monarch flight diverter netting materials and costs for five land-based testing sites.**

Item	Structure Unit Type	Unit	Units Needed	Unit Price	Sales Units	Sales Unit Price	Sales Units Needed	Shipping	Sales Tax	Total Price	Source
Sign Post Placement and Placard Installation		1/2 hr per sign	1 hr	2 x 0.5 = 1	\$40.00/hr (2 people)	1 hr	\$40	1			\$40.00
12' x 16' Tarp and Support Pole Removal (after 2 weeks)		1/2 hr per tarp	1 hr	33 x 0.5 = 16.5	\$40.00/hr (2 people)	1 hr	\$40	16.5			\$660.00
<b>Subtotal Labor</b>											<b>\$1,360.00</b>
<b>Total Maintenance Cost per 473.25 ft (1 site)</b>											<b>\$1,588.09</b>
<b>Total Maintenance Cost per ft</b>											<b>\$3.36</b>



**Table F.3. Roadside pollinator habitat materials for all seven sites.**

Item	Structure Unit Type	Unit	Units Needed	Unit Price	Sales Units	Sales Unit Price	Sales Units Needed	Shipping	Sales Tax	Total Price	Source
<i>Seeds</i>											
Antelopehorns ( <i>Asclepias asperula</i> subsp. <i>capricornu</i> )	seed	1	Twice needed for plots = 2 x 540 = 1080	\$0.0725 (per 400)	D-PAK 400	\$29.00	3			\$87.00	<a href="https://www.seedsourc.com/catalog/detail.asp?product_id=3068">https://www.seedsourc.com/catalog/detail.asp?product_id=3068</a>
Antelopehorns ( <i>Asclepias viridis</i> )	seed	1	Twice needed for plots = 2 x 540 = 1080	\$0.0725 (per 400)	D-PAK 400	\$29.00	1			\$29.00	<a href="https://www.seedsourc.com/catalog/detail.asp?PRODUCT_ID=3101">https://www.seedsourc.com/catalog/detail.asp?PRODUCT_ID=3101</a>
Zizotes Milkweed ( <i>Asclepias oenotheroides</i> )	seed	1	Twice needed for plots = 2 x 900 = 1800	\$0.15 (per 20)	pkt 20	\$3.00	54			\$162.00	<a href="https://www.dkseeds.com/product/mariposa-zizotes-milkweed/">https://www.dkseeds.com/product/mariposa-zizotes-milkweed/</a>
Broadleaf Milkweed ( <i>Asclepias latifolia</i> )	seed	1	Twice needed for plots = 2 x 180 = 1360	\$0.67 (per 15)	pkt 15	\$10.00	8			\$80.00	<a href="https://www.growmilkweedplants.com/store/p76/Broadleaf_milkweed%2C_Asclepias_latifolia_seeds.html">https://www.growmilkweedplants.com/store/p76/Broadleaf_milkweed%2C_Asclepias_latifolia_seeds.html</a>
Clasping Milkweed ( <i>Asclepias amplexicaulis</i> )	seed	1	Twice needed for plots = 2 x 60 = 120		1	\$0.34	200			\$68.00	East Texas

**Table F.3. Roadside pollinator habitat materials for all seven sites.**

Item	Structure Unit Type	Unit	Units Needed	Unit Price	Sales Units	Sales Unit Price	Sales Units Needed	Shipping	Sales Tax	Total Price	Source
				\$17/hr = \$68/200 = \$0.34							
Emory's Milkweed ( <i>Asclepias emoryi</i> )	seed	1	Twice needed for plots = 2 x 180 = 360	Not Commercially Available - Labor to gather four ripe seed pods (ca. 100 seeds per pod)- 8 hrs at \$17/hr = \$136/400 = \$0.34	1	\$0.34	400			\$136.00	South Texas
Prairie verbena ( <i>Glandularia bipinnatifida</i> )	seed	1	Twice needed for plots = 2 x 180 = 360	\$0.0725 (per 400)	dpak 400	\$29.00	1			\$29.00	<a href="https://www.seedsources.com/catalog/detail.asp?PRODUCT_ID=3067">https://www.seedsources.com/catalog/detail.asp?PRODUCT_ID=3067</a>

**Table F.3. Roadside pollinator habitat materials for all seven sites.**

Item	Structure Unit Type	Unit	Units Needed	Unit Price	Sales Units	Sales Unit Price	Sales Units Needed	Shipping	Sales Tax	Total Price	Source
Texas Vervain ( <i>Verbena halei</i> )	seed	1	Twice needed for plots = 2 x 180 = 360	Not Commercially Available - Labor to gather about 20 seeding plants to dry with about 20 seeds each- 8 hrs at \$17/hr = \$136/400 = \$0.34	1	\$0.34	400			\$136.00	Central Texas
Lance-leaved coreopsis ( <i>Coreopsis lanceolata</i> )	seed	1	Twice needed for plots = 2 x 180 = 360	--	pkt 400?	\$3.00	1			\$3.00	<a href="https://www.seedsources.com/catalog/detail.asp?PRODUCT_ID=3056">https://www.seedsources.com/catalog/detail.asp?PRODUCT_ID=3056</a>
Plains coreopsis ( <i>Coreopsis tinctoria</i> )	seed	1	Twice needed for plots = 2 x 90 = 180	--	pkt 400?	\$3.00	1			\$3.00	<a href="https://www.seedsources.com/catalog/detail.asp?PRODUCT_ID=1003">https://www.seedsources.com/catalog/detail.asp?PRODUCT_ID=1003</a>
Engelmann Daisy ( <i>Enelmannia peristenia</i> )	seed	1	Twice needed for plots = 2 x 270 = 540	--	pkt 100?	\$3.00	6			\$18.00	<a href="https://www.seedsources.com/catalog/detail.asp?PRODUCT_ID=1014">https://www.seedsources.com/catalog/detail.asp?PRODUCT_ID=1014</a>

**Table F.3. Roadside pollinator habitat materials for all seven sites.**

Item	Structure Unit Type	Unit	Units Needed	Unit Price	Sales Units	Sales Unit Price	Sales Units Needed	Shipping	Sales Tax	Total Price	Source
Lemon Beebalm ( <i>Monarda citriodora</i> )	seed	1	Twice needed for plots = 2 x 90 = 180	--	pkt 400?	\$3.00	1			\$3.00	<a href="https://www.seedsources.com/catalog/detail.asp?PRODUCT_ID=1006">https://www.seedsources.com/catalog/detail.asp?PRODUCT_ID=1006</a>
Maximillian Sunflower ( <i>Helianthus maximiliana</i> )	seed	1	Twice needed for plots = 2 x 90 = 180	--	pkt 100?	\$3.00	2			\$6.00	<a href="https://www.seedsources.com/catalog/detail.asp?PRODUCT_ID=1018">https://www.seedsources.com/catalog/detail.asp?PRODUCT_ID=1018</a>
Heath Aster ( <i>Symphyotrichum ericoides</i> )	seed	1	Twice needed for plots = 2 x 270 = 540	--	XL Mylar Pkt 2000	\$3.75	1			\$3.75	<a href="https://www.everwilde.com/store/Aster-ericoides-WildFlower-Seed.html">https://www.everwilde.com/store/Aster-ericoides-WildFlower-Seed.html</a>
Golden Crownbeard ( <i>Verbesina enceliodes</i> )	seed	1	Twice needed for plots = 2 x 90 = 180	--	pkt 400?	\$3.00	1			\$3.00	<a href="https://www.seedsources.com/catalog/detail.asp?PRODUCT_ID=3054">https://www.seedsources.com/catalog/detail.asp?PRODUCT_ID=3054</a>
Dotted Blazing Star ( <i>Liatis punctata</i> )	seed	1	Twice needed for plots = 2 x 270 = 540	--	pkt 100	\$2.98	6			\$17.88	<a href="https://www.everwilde.com/store/Liatis-punctata-WildFlower-Seed.html">https://www.everwilde.com/store/Liatis-punctata-WildFlower-Seed.html</a>
Zexmania ( <i>Wedelia acapulcensis</i> var. <i>hispida</i> )	seed	1	Twice needed for plots = 2 x 180 = 360	Not Commercially Available - Labor to gather about 20 seeding plants to dry with	1	\$0.34	400			\$136.00	Central Texas



**Table F.3. Roadside pollinator habitat materials for all seven sites.**

Item	Structure Unit Type	Unit	Units Needed	Unit Price	Sales Units	Sales Unit Price	Sales Units Needed	Shipping	Sales Tax	Total Price	Source
				about 20 seeds each- 8 hrs at \$17/hr = \$136/400 = \$0.34							
Texas Thistle ( <i>Cirsium texanum</i> )	seed	1	Twice needed for plots = 2 x 180 = 360	--	pkt 400?	\$6.00	1			\$6.00	<a href="https://www.seedsources.com/catalog/detail.asp?PRODUCT_ID=3175">https://www.seedsources.com/catalog/detail.asp?PRODUCT_ID=3175</a>
Spanish Gold ( <i>Grindelia ciliata</i> )	seed	1	Twice needed for plots = 2 x 90 = 180	Not Commercially Available - Labor to gather about 10 seeding plants to dry with about 20 seeds each- 8 hrs at \$17/hr = \$136/200 = \$0.68	1	\$0.68	60			\$40.80	West Central Texas

**Table F.3. Roadside pollinator habitat materials for all seven sites.**

Item	Structure Unit Type	Unit	Units Needed	Unit Price	Sales Units	Sales Unit Price	Sales Units Needed	Shipping	Sales Tax	Total Price	Source
Bitterweed ( <i>Helenium amarum</i> )	seed	1	Twice needed for plots = 2 x 90 = 180	Not Commercially Available - Labor to gather about 10 seeding plants to dry with about 20 seeds each- 8 hrs at \$17/hr = \$136/200 = \$0.68	1	\$0.68	60			\$40.80	West Central Texas
Black-eyed Susan ( <i>Rudbeckia hirta</i> )	seed	1	Twice needed for plots = 2 x 90 = 180	--	pkt 400?	\$3.00	1			\$3.00	<a href="https://www.seedsources.com/catalog/detail.asp?PRODUCT_ID=1007">https://www.seedsources.com/catalog/detail.asp?PRODUCT_ID=1007</a>
Subtotal										\$1,011.23	-
<p><i>Stratification Mix:</i> 1 part perlite, 1 part vermiculite, (Ladybird Johnson Wildflower Center 2018, <a href="https://www.wildflower.org/learn/how-to/how-to-germinate-milkweeds#:~:text=Soak%20milkweed%20seeds%20in%20water,for%20at%20least%20two%20weeks.">https://www.wildflower.org/learn/how-to/how-to-germinate-milkweeds#:~:text=Soak%20milkweed%20seeds%20in%20water,for%20at%20least%20two%20weeks.</a> ) (5,040 plants x 2)/10 seeds per ziploc bag = 1008 ziploc bags x 0.02825 cu ft = 28.5 cu ft stratification mix</p>											
Peat Moss	1 cu ft	1	.5 *28.5 cu ft = 14.25 cu ft	\$3.65	3 cu. ft	\$10.97	5			\$54.85	<a href="https://www.homedepot.com/p/3-cu-ft-Peat-Moss-3001-CFC003P/205883917">https://www.homedepot.com/p/3-cu-ft-Peat-Moss-3001-CFC003P/205883917</a>
Perlite	1 cu ft	1	.5 *28.5 cu ft = 14.25 cu ft	\$10.00	4 cu. Ft	\$40	4			\$160.00	<a href="https://www.homedepot.com/p/Viagrow-4-cu-ft-Perlite-VPER4/207112647">https://www.homedepot.com/p/Viagrow-4-cu-ft-Perlite-VPER4/207112647</a>
Subtotal										\$214.85	

**Table F.3. Roadside pollinator habitat materials for all seven sites.**

Item	Structure Unit Type	Unit	Units Needed	Unit Price	Sales Units	Sales Unit Price	Sales Units Needed	Shipping	Sales Tax	Total Price	Source
<p><i>Germination Mix</i>: 1 part perlite, 1 part vermiculite, 1 part peat moss (Ly 2022, <a href="https://www.gardenbetty.com/how-to-make-your-own-seed-starting-and-potting-mix/">https://www.gardenbetty.com/how-to-make-your-own-seed-starting-and-potting-mix/</a>) - mix for 336 germination trays (see below) x 0.2625 cu ft per tray = 89 cu ft</p>											
Peat Moss	1 cu ft	1	.33 *89 = 29.4 cu ft	\$3.65	3 cu. ft	\$10.97	10			\$109.70	<a href="https://www.homedepot.com/p/3-cu-ft-Peat-Moss-3001-CFC003P/205883917">https://www.homedepot.com/p/3-cu-ft-Peat-Moss-3001-CFC003P/205883917</a>
Perlite	1 cu ft	1	.33 *89 = 29.4 cu ft	\$10.00	4 cu. Ft	\$40	8			\$320.00	<a href="https://www.homedepot.com/p/Viagrow-4-cu-ft-Perlite-VPER4/207112647">https://www.homedepot.com/p/Viagrow-4-cu-ft-Perlite-VPER4/207112647</a>
Vermiculite	1 cu ft	1	.33 *89 = 29.4 cu ft	\$10,99	2 cu. Ft	\$21.99	15			\$329.85	<a href="https://www.homedepot.com/p/Vigoro-2-cu-ft-Organic-Vermiculite-Soil-Amendment-100521092/205655205">https://www.homedepot.com/p/Vigoro-2-cu-ft-Organic-Vermiculite-Soil-Amendment-100521092/205655205</a>
Subtotal										\$759.55	
<p><i>Growing Mix (potting mix succulents/cacti)</i>: 42.8% (3 parts) peat moss, (14%) 1 part perlite, (14%) 1 part vermiculite, 29% (2 parts) coarse sand, (0.1%) 0.008 parts lime (Walliser 2019, <a href="https://savvygardening.com/">https://savvygardening.com/</a>): ½ quart per 4" pot = 0.01671007 cu. ft x 6,300 pots (see below) = 106 cu ft</p>											
Peat Moss	1 cu ft	1	.428 * 106 cu ft = 45.4 cu ft	\$3.65	3 cu. ft	\$10.97	10			\$109.70	<a href="https://www.homedepot.com/p/3-cu-ft-Peat-Moss-3001-CFC003P/205883917">https://www.homedepot.com/p/3-cu-ft-Peat-Moss-3001-CFC003P/205883917</a>
Perlite	1 cu ft	1	.14 * 106 cu ft = 14.84 cu ft	\$10.00	4 cu. Ft	\$40	4			\$160.00	<a href="https://www.homedepot.com/p/Viagrow-4-cu-ft-Perlite-VPER4/207112647">https://www.homedepot.com/p/Viagrow-4-cu-ft-Perlite-VPER4/207112647</a>
Vermiculite	1 cu ft	1	.14 * 106 cu ft = 14.84 cu ft	\$10,99	2 cu. Ft	\$21.99	8			\$175.92	<a href="https://www.homedepot.com/p/Vigoro-2-cu-ft-Organic-Vermiculite-Soil-Amendment-100521092/205655205">https://www.homedepot.com/p/Vigoro-2-cu-ft-Organic-Vermiculite-Soil-Amendment-100521092/205655205</a>

**Table F.3. Roadside pollinator habitat materials for all seven sites.**

Item	Structure Unit Type	Unit	Units Needed	Unit Price	Sales Units	Sales Unit Price	Sales Units Needed	Shipping	Sales Tax	Total Price	Source
Sand	1 lb.	1	.29 * 106 cu ft = 30.7 cu ft	\$0.08	50 lb = 0.5 cu ft	\$3.97	62			\$246.14	<a href="https://www.homedepot.com/p/50-lb-Natural-Play-Sand-100033813/100632108">https://www.homedepot.com/p/50-lb-Natural-Play-Sand-100033813/100632108</a>
Lime	1 lb	1	.001 * 106 cu ft = 0.106 cu ft (6.34 pts)	\$0.63	30 lb = 0.75 cu ft	\$19.01	1			\$19.01	<a href="https://www.homedepot.com/p/2-5-lbs-500-sq-ft-Fast-Acting-Lime-with-Nutri-Bond-12131/316371358#overlay">https://www.homedepot.com/p/2-5-lbs-500-sq-ft-Fast-Acting-Lime-with-Nutri-Bond-12131/316371358#overlay</a>
Subtotal										\$710.77	
<i>Containers</i>											
5" x 8" 3 mil Zipper Bags for Seed Stratification	1	1	1008	\$0.03	1000	\$34.01	1	\$10.90		\$44.91	<a href="https://www.uspolypack.com/Zip-Reclosable-Lock-Bags-3-Mils-c-1176.html">https://www.uspolypack.com/Zip-Reclosable-Lock-Bags-3-Mils-c-1176.html</a>
10" x 20" Propagation Starter Seedling Trays with Holes for Germination	1	1	10,080 seeds/30 seeds per tray = 336	\$1.31	100	\$130.94	4			\$523.76	<a href="https://www.homedepot.com/p/Viagrow-10-in-x-20-in-Propagation-Starter-Seedling-Trays-with-Holes-100-Pack-V726167-100/314981293">https://www.homedepot.com/p/Viagrow-10-in-x-20-in-Propagation-Starter-Seedling-Trays-with-Holes-100-Pack-V726167-100/314981293</a>
4 in Round Peat Pots for Seedlings	1	1	Pot 25% more seedlings than needed = 5040 + (5040 * 0.25) = 6,300	\$0.15	960	\$139.50	7			\$976.50	<a href="https://www.greenhousemegastore.com/containers-trays/plant-pots/jiffy-peat-pots?returnurl=%2fsearch%3fq%3dpeat%2bpots">https://www.greenhousemegastore.com/containers-trays/plant-pots/jiffy-peat-pots?returnurl=%2fsearch%3fq%3dpeat%2bpots</a>





**Table F.3. Roadside pollinator habitat materials for all seven sites.**

Item	Structure Unit Type	Unit	Units Needed	Unit Price	Sales Units	Sales Unit Price	Sales Units Needed	Shipping	Sales Tax	Total Price	Source
6" biodegradable landscape stake	1	1	4 x 40 subplots x 3 plots x 7 sites = 3,360	\$0.23	100	\$23.49	34			\$798.66	<a href="https://www.homedepot.com/p/Ecoduty-6-in-Degradable-Landscape-Stake-100-Pack-EDS-6D-100/205501764?g_store=&amp;source=shoppingads&amp;locale=en-US&amp;pla&amp;mtc=Shopping-CM-F_D29A-G-D29A-Multi-Multi-NA-NA-PLA_LIA-NA-NA-MinorAppl_Special_Buys&amp;cm_mmc=Shopping-CM-F_D29A-G-D29A-Multi-Multi-NA-NA-PLA_LIA-NA-NA-MinorAppl_Special_Buys-71700000042813121-58700005464629311-92700067963002094&amp;gclid=Cj0KCQIAmKiQBhCIA RIsAKTSi-kANEinOS74OhBBic7rjCE51AlAeA3LQg2twy4KvH14pmLqqaIckr8aAjVpEALw_wcB&amp;gclid=aw.ds">https://www.homedepot.com/p/Ecoduty-6-in-Degradable-Landscape-Stake-100-Pack-EDS-6D-100/205501764?g_store=&amp;source=shoppingads&amp;locale=en-US&amp;pla&amp;mtc=Shopping-CM-F_D29A-G-D29A-Multi-Multi-NA-NA-PLA_LIA-NA-NA-MinorAppl_Special_Buys&amp;cm_mmc=Shopping-CM-F_D29A-G-D29A-Multi-Multi-NA-NA-PLA_LIA-NA-NA-MinorAppl_Special_Buys-71700000042813121-58700005464629311-92700067963002094&amp;gclid=Cj0KCQIAmKiQBhCIA RIsAKTSi-kANEinOS74OhBBic7rjCE51AlAeA3LQg2twy4KvH14pmLqqaIckr8aAjVpEALw_wcB&amp;gclid=aw.ds</a>
Subtotal										\$2,131.06	
<i>Plot Protection Barrier</i>											
4' U Post Stakes	1	1	16 per plot x 3 plots x 7 sites = 336	\$5.71	1	\$5.71	336			\$1,918.56	<a href="https://www.homedepot.com/p/Everbilt-2-1-4-in-x-2-1-2-in-x-4-ft-Green-Steel-Fence-U-Post-901154EB/205960882?source=shoppingads&amp;locale=en-US&amp;pla&amp;mtc=Shopping-CM-F_D29A-G-D29A-Multi-Multi-NA-NA-PLA_LIA-NA-NA-MinorAppl_Special_Buys">https://www.homedepot.com/p/Everbilt-2-1-4-in-x-2-1-2-in-x-4-ft-Green-Steel-Fence-U-Post-901154EB/205960882?source=shoppingads&amp;locale=en-US&amp;pla&amp;mtc=Shopping-CM-F_D29A-G-D29A-Multi-Multi-NA-NA-PLA_LIA-NA-NA-MinorAppl_Special_Buys</a>

**Table F.3. Roadside pollinator habitat materials for all seven sites.**

Item	Structure Unit Type	Unit	Units Needed	Unit Price	Sales Units	Sales Unit Price	Sales Units Needed	Shipping	Sales Tax	Total Price	Source
											<a href="https://www.seton.com/stripped-nylon-barricade-tape-8303d.html">https://www.seton.com/stripped-nylon-barricade-tape-8303d.html</a>
2" Nylon Barrier Tape	1 ft	1	396' perimeter x 3 plots x 7 sites = 8,316 ft	\$0.15	150 ft roll	\$22.40	56			\$1,254.40	<a href="https://www.seton.com/stripped-nylon-barricade-tape-8303d.html">https://www.seton.com/stripped-nylon-barricade-tape-8303d.html</a>
15" x 0.317" 350 lbs Tensile Strength Stainless Steel Cable Ties	cable tie	1	16 per plot x 3 plots x 7 sites = 336	\$0.29	pk 100	\$28.55	4	\$11.34	\$16.90	\$142.44	<a href="https://www.cabletiesandmore.com/stainless-steel-cable-ties?pid=58">https://www.cabletiesandmore.com/stainless-steel-cable-ties?pid=58</a>
Subtotal										\$3,315.40	
<i>Signage for Pollinator Habitat</i>											
12' ht 2.875" (2 7/8") OD 10 BWG Steel Tubing	1	1	1 per site x 7 sites = 7	\$109.00	1	109	7			\$763.00	Quote from Texas Corrugators ( <a href="http://www.txcorr.com">http://www.txcorr.com</a> ) for 7 qty, 2/14/2022
10' ht 2.875" (2 7/8") OD 10 BWG Steel Tubing	1	1	2 per site x 7 sites = 14	\$91.00	1	91	14			\$1,274.00	Quote from Texas Corrugators (Fig. F.1) ( <a href="http://www.txcorr.com">http://www.txcorr.com</a> ) for 45 qty, 2/14/2022
Triangular Slip Base Casting with Keeper Plate and Bolts (Top Post Receiver)	1	1	3 per site x 7 sites = 21	\$42.00	1	\$42.00	21			\$882.00	Quote from Texas Corrugators ( <a href="http://www.txcorr.com">http://www.txcorr.com</a> ) for 220 qty, 2/14/2022
Triangular Slip Base 3" x 3' Stub (Bottom Anchor)	1	1	3 per site x 7 sites = 21	\$77.00	1	\$77.00	21			\$1,617.00	Quote from Texas Corrugators

**Table F.3. Roadside pollinator habitat materials for all seven sites.**

Item	Structure Unit Type	Unit	Units Needed	Unit Price	Sales Units	Sales Unit Price	Sales Units Needed	Shipping	Sales Tax	Total Price	Source
											(http://www.txcorr.com) for 220 qty, 2/14/2022
42" x 24" Blue/White Public "TxDOT Monarch Protection" Sign	1	1	1 per site x 7 sites = 7	\$71.03 (if 5)	1	\$71.03	7			\$497.21	https://www.signs.com/design/?id=8ef224be-6d30-4616-8781-586058b7a788
42" x 24" Blue/White Non-Public "TxDOT Special Management Area Monarch Projection ID" Sign	1	1	1 per site x 7 sites = 7	\$86.50	1	\$86.50	7			\$605.50	https://www.signs.com/design/?id=8ef224be-6d30-4616-8781-586058b7a788
18" x 24" Blue/White Non-Public "Do Not Mow/Do Not Spray" Sign	1	1	2 per site x 7 sites = 14	\$29.84 if 42	1	\$29.94	14			\$419.16	https://www.signs.com/design/?id=8ef224be-6d30-4616-8781-586058b7a788
U-Clamp Sign Hardware, 2.5"	1	1	2 x 4 signs per site x 7 sites = 56	\$3.39	1	\$3.39	56			\$189.84	<a href="http://www.txcorr.com">Quote from Texas Corrugators (http://www.txcorr.com) for 118 qty, 2/14/2022</a>
Class "A" Concrete (3,500 psi) (TxDOT Item 04206133)	2.5 Cubic Ft per Post Hole	1 cu yard (27 cu ft)	(2.5 x 3)/27 = 0.28 cu yd per site x 7 sites = 2 cu yds	\$310/cu yd	1 cu yd	\$310	2			\$620.00	<a href="https://ftp.dot.state.tx.us/pub/txdot/cst/average-low-bid/hwy-construction/ALB-C-2.xlsm">https://ftp.dot.state.tx.us/pub/txdot/cst/average-low-bid/hwy-construction/ALB-C-2.xlsm</a>
Subtotal										\$6,867.71	
Labor											
Greenhouse Propagation											
Stratification	day	1	3 days	\$17/hr x 8 hr = \$136	1	\$136.00	3			\$408.00	Estimate 10 days
Germination	day	1	5 days	\$17/hr x 8 hr = \$136	1	\$136.00	5			\$680.00	Estimate 10 days
Seedling Transplanting	day	1	7 days	\$17/hr x 8 hr = \$136	1	\$136.00	7			\$952.00	Estimate 5 days
Seedling Tending for 3.5 mos	day	1	14 wks x 2 days per week = 24 days	\$17/hr x 8 hr = \$136	1	\$136.00	24			\$3,264.00	Estimate 24 days



**Table F.3. Roadside pollinator habitat materials for all seven sites.**

Item	Structure Unit Type	Unit	Units Needed	Unit Price	Sales Units	Sales Unit Price	Sales Units Needed	Shipping	Sales Tax	Total Price	Source
Subtotal										\$5,304.00	
Field Preparation/Signage/Transplanting											
Installing Plot Barriers	day	1	1/2 day per site x 7 sites = 3.5 days	\$17/hr x 8 hr = \$136	1	\$136.00	3.5			\$476.00	Estimate 3.5 days
Triangular Slip Base 3" x 3' Stud (Bottom Anchor) Installation	1	1	3 per site x 7 sites = 21	\$196.35	1	\$196.35	21			\$4,123.35	<a href="http://legacy.elpasotexas.gov/purchasing/docs/2020-716%20Transit%20System%20Site%20Improvements.pdf">Estimate from: http://legacy.elpasotexas.gov/purchasing/docs/2020-716%20Transit%20System%20Site%20Improvements.pdf</a>
Sign Post Placement and Placard Installation	1/2 hr per sign	1 hr	4 per site x 7 sites x 0.5 hr = 14	\$40.00/hr (2 people)	1 hr	\$40	14			\$560.00	Estimate 30 minutes per sign at \$40/hr
Site Installation of Sheet Mulch	day	1	1 day per site x 7 sites = 7 days	\$17/hr x 8 hr = \$136	1	\$136.00	7			\$952.00	Estimate 7 days
Transplanting to Sites	day	1	2 days per site x 7 sites = 14 days	\$17/hr x 8 hr = \$136	1	\$136.00	14			\$1,904.00	Estimate 14 days
Field Watering/Weeding Monthly for Six Months of First Year	day	1	0.5 day per site x 7 sites x six months = 24 days	\$17/hr x 8 hr = \$136	1	\$136.00	24			\$3,264.00	Estimate 24 days
Subtotal										\$11,279.35	
<b>TOTAL Materials</b>										<b>\$16,555.74</b>	
<b>TOTAL Labor</b>										<b>\$16,583.35</b>	
<b>GRAND TOTAL</b>										<b>\$33,139.09</b>	

**Table F.3. Roadside pollinator habitat materials for all seven sites.**

Item	Structure Unit Type	Unit	Units Needed	Unit Price	Sales Units	Sales Unit Price	Sales Units Needed	Shipping	Sales Tax	Total Price	Source
<b>Cost per Pllinator Habitat Site Materials and Installation (1/7)</b>										<b>\$4,734.16</b>	
<b>Cost per Foot Pollinator Site Materials and Installation (150' per plot x 6 plots x 7 sites = 6,300 ft)</b>										<b>\$10.52</b>	
<b>Annual Maintenance per Site</b>											
<i>Materials Every Two Years</i>											
2" Nylon Barrier Tape	1 ft	1	396' perimeter x 3 plots = 1,188 ft/ 2 yrs = 594	\$0.15	150 ft roll	\$22.40	4			\$89.60	<a href="https://www.seton.com/striped-nylon-barricade-tape-8303d.html">https://www.seton.com/striped-nylon-barricade-tape-8303d.html</a>
15" x 0.317" 350 lbs Tensile Strength Stainless Steel Cable Ties	cable tie	1	16 per plot x 3 plots = 48/2yrs = 24	\$0.29	pk 100	\$28.55	1	\$11.34	\$16.90	\$56.79	<a href="https://www.cabletiesandmore.com/stainless-steel-cable-ties?pid=58">https://www.cabletiesandmore.com/stainless-steel-cable-ties?pid=58</a>
Subtotal Materials										\$146.39	
<i>Labor</i>											
Mowing/Weeding Twice per Year After First Year	day	1	0.25 day per site x 2 months = 0.5 days	\$17/hr x 8 hr = \$136	1	\$136.00	0.5			\$68.00	Estimate 7 days
<b>Total Maintenance Cost per 900 ft (1 site = 150 ft x 6)</b>										<b>\$214.39</b>	
<b>Total Maintenance Cost per ft</b>										<b>\$0.48</b>	

**Table F.4. Roadside non-planted pollinator habitat materials for all seven sites.**

Item	Structure Unit Type	Unit	Units Needed	Unit Price	Sales Units	Sales Unit Price	Sales Units Needed	Shipping	Sales Tax	Total Price	Source
<i>Plot Protection Barrier</i>											
4' U Post Stakes	1	1	16 per plot x 3 plots x 7 sites = 336	\$5.71	1	\$5.71	336			\$1,918.56	<a href="https://www.homedepot.com/p/E-verbilt-2-1-4-in-x-2-1-2-in-x-4-ft-Green-Steel-Fence-U-Post-901154EB/205960882?source=shoppingads&amp;locale=en-US&amp;pla&amp;mtc=Shopping-CM-F_D29A-G-D29A-Multi-Multi-NA-NA-PLA_LIA-NA-NA-MinorAppl_Special_Buys&amp;cm_mm_c=Shopping-CM-F_D29A-G-D29A-Multi-Multi-NA-NA-PLA_LIA-NA-NA-MinorAppl_Special_Buys-7170000042813121-58700005464629311-92700067963002094&amp;gclid=Cj0KCQIAu62QBhC7ARIsALXijXSDKpmKm8xqLLP4AW2eLyBeAbB3cmXeaqY1F68-PO9itDK0-GXNZQaAieuFALw_wcB&amp;gclsrc=aw.ds">https://www.homedepot.com/p/E-verbilt-2-1-4-in-x-2-1-2-in-x-4-ft-Green-Steel-Fence-U-Post-901154EB/205960882?source=shoppingads&amp;locale=en-US&amp;pla&amp;mtc=Shopping-CM-F_D29A-G-D29A-Multi-Multi-NA-NA-PLA_LIA-NA-NA-MinorAppl_Special_Buys&amp;cm_mm_c=Shopping-CM-F_D29A-G-D29A-Multi-Multi-NA-NA-PLA_LIA-NA-NA-MinorAppl_Special_Buys-7170000042813121-58700005464629311-92700067963002094&amp;gclid=Cj0KCQIAu62QBhC7ARIsALXijXSDKpmKm8xqLLP4AW2eLyBeAbB3cmXeaqY1F68-PO9itDK0-GXNZQaAieuFALw_wcB&amp;gclsrc=aw.ds</a>
2" Nylon Barrier Tape	1 ft	1	396' perimeter x 3 plots x 7 sites = 8,316 ft	\$0.15	150 ft roll	\$22.40	56			\$1,254.40	<a href="https://www.seton.com/striped-nylon-barricade-tape-8303d.html">https://www.seton.com/striped-nylon-barricade-tape-8303d.html</a>
15" x 0.317" 350 lbs Tensile Strength Stainless Steel Cable Ties	cable tie	1	16 per plot x 3 plots x 7 sites = 336	\$0.29	pk 100	\$28.55	4	\$11.34	\$16.90	\$142.44	<a href="https://www.cabletiesandmore.com/stainless-steel-cable-ties?pid=58">https://www.cabletiesandmore.com/stainless-steel-cable-ties?pid=58</a>
Subtotal										\$3,315.40	
<i>Signage for Pollinator Habitat</i>											
	1	1	1 per site x 7 sites = 7	\$109.00	1	109	7			\$763.00	

**Table F.4. Roadside non-planted pollinator habitat materials for all seven sites.**

Item	Structure Unit Type	Unit	Units Needed	Unit Price	Sales Units	Sales Unit Price	Sales Units Needed	Shipping	Sales Tax	Total Price	Source
12' ht 2.875" (2 7/8") OD 10 BWG Steel Tubing											Quote from Texas Corrugators ( <a href="http://www.txcorr.com">http://www.txcorr.com</a> ) for 7 qty, 2/14/2022
10' ht 2.875" (2 7/8") OD 10 BWG Steel Tubing	1	1	2 per site x 7 sites = 14	\$91.00	1	91	14			\$1,274.00	Quote from Texas Corrugators (Fig. F.1) ( <a href="http://www.txcorr.com">http://www.txcorr.com</a> ) for 45 qty, 2/14/2022
Triangular Slip Base Casting with Keeper Plate and Bolts (Top Post Receiver)	1	1	3 per site x 7 sites = 21	\$42.00	1	\$42.00	21			\$882.00	Quote from Texas Corrugators ( <a href="http://www.txcorr.com">http://www.txcorr.com</a> ) for 220 qty, 2/14/2022
Triangular Slip Base 3" x 3' Stub (Bottom Anchor)	1	1	3 per site x 7 sites = 21	\$77.00	1	\$77.00	21			\$1,617.00	Quote from Texas Corrugators ( <a href="http://www.txcorr.com">http://www.txcorr.com</a> ) for 220 qty, 2/14/2022
42" x 24" Blue/White Public "TxDOT Monarch Protection" Sign	1	1	1 per site x 7 sites = 7	\$71.03 (if 5)	1	\$71.03	7			\$497.21	<a href="https://www.signs.com/design/?id=8ef224be-6d30-4616-8781-586058b7a788">https://www.signs.com/design/?id=8ef224be-6d30-4616-8781-586058b7a788</a>



**Table F.4. Roadside non-planted pollinator habitat materials for all seven sites.**

Item	Structure Unit Type	Unit	Units Needed	Unit Price	Sales Units	Sales Unit Price	Sales Units Needed	Shipping	Sales Tax	Total Price	Source
42" x 24" Blue/White Non-Public "TxDOT Special Management Area Monarch Projection ID" Sign	1	1	1 per site x 7 sites = 7	\$86.50	1	\$86.50	7			\$605.50	<a href="https://www.signs.com/design/?id=8ef224be-6d30-4616-8781-586058b7a788">https://www.signs.com/design/?id=8ef224be-6d30-4616-8781-586058b7a788</a>
18" x 24" Blue/White Non-Public "Do Not Mow/Do Not Spray" Sign	1	1	2 per site x 7 sites = 14	\$29.84 if 42	1	\$29.94	14			\$419.16	<a href="https://www.signs.com/design/?id=8ef224be-6d30-4616-8781-586058b7a788">https://www.signs.com/design/?id=8ef224be-6d30-4616-8781-586058b7a788</a>
U-Clamp Sign Hardware, 2.5"	1	1	2 x 4 signs per site x 7 sites = 56	\$3.39	1	\$3.39	56			\$189.84	<a href="http://www.txcorr.com">Quote from Texas Corrugators (http://www.txcorr.com) for 118 qty, 2/14/2022</a>
Class "A" Concrete (3,500 psi) (TxDOT Item 04206133)	2.5 Cubic Ft per Post Hole	1 cu yard (27 cu ft)	(2.5 x 3)/27 = 0.28 cu yd per site x 7 sites = 2 cu yds	\$310/cu yd	1 cu yd	\$310	2			\$620.00	<a href="https://ftp.dot.state.tx.us/pub/txdot/cst/average-low-bid/hwy-construction/ALB-C-2.xlsm">https://ftp.dot.state.tx.us/pub/txdot/cst/average-low-bid/hwy-construction/ALB-C-2.xlsm</a>
Subtotal										\$6,867.71	
Labor											
Field Barrier Installation											
Installing Plot Barriers	day	1	1/2 day per site x	\$17/hr x 8 hr = \$136	1	\$136.00	3.5			\$476.00	Estimate 3.5 days

**Table F.4. Roadside non-planted pollinator habitat materials for all seven sites.**

Item	Structure Unit Type	Unit	Units Needed	Unit Price	Sales Units	Sales Unit Price	Sales Units Needed	Shipping	Sales Tax	Total Price	Source
			7 sites = 3.5 days								
Triangular Slip Base 3" x 3' Stud (Bottom Anchor) Installation	1	1	3 per site x 7 sites = 21	\$196.35	1	\$196.35	21			\$4,123.35	Estimate from: <a href="http://legacy.elpasotexas.gov/purchasing/docs/2020-716%20Transit%20System%20Site%20Improvements.pdf">http://legacy.elpasotexas.gov/purchasing/docs/2020-716%20Transit%20System%20Site%20Improvements.pdf</a>
Sign Post Placement and Placard Installation	1/2 hr per sign	1 hr	4 per site x 7 sites x 0.5 hr = 14	\$40.00/hr (2 people)	1 hr	\$40	14			\$560.00	Estimate 30 minutes per sign at \$40/hr
Mowing/Weeding Twice per Year After First Year	day	1	0.25 day per site x 2 months x 7 sites = 0.5 days	\$17/hr x 8 hr = \$136	1	\$136.00	3.5			\$476.00	Estimate 7 days
Subtotal										\$5,635.35	
<b>TOTAL Materials</b>										<b>\$10,183.11</b>	
<b>TOTAL Labor</b>										<b>\$5,635.35</b>	
<b>GRAND TOTAL</b>										<b>\$15,818.46</b>	
<b>Cost per Non-Planted Pollinator Habitat Site Materials and Installation (1/7)</b>										<b>\$2,259.78</b>	
<b>Cost per Foot Non-Planted Pollinator Site Materials and Installation (150' per plot x 6 plots x 7 sites = 6,300 ft)</b>										<b>\$5.02</b>	

**Table F.4. Roadside non-planted pollinator habitat materials for all seven sites.**

Item	Structure Unit Type	Unit	Units Needed	Unit Price	Sales Units	Sales Unit Price	Sales Units Needed	Shipping	Sales Tax	Total Price	Source
<b>Annual Maintenance per Site</b>											
<i>Materials Every Two Years</i>											
2" Nylon Barrier Tape	1 ft	1	396' perimeter x 3 plots = 1,188 ft/ 2 yrs = 594	\$0.15	150 ft roll	\$22.40	4			\$89.60	<a href="https://www.seton.com/striped-nylon-barricade-tape-8303d.html">https://www.seton.com/striped-nylon-barricade-tape-8303d.html</a>
15" x 0.317" 350 lbs Tensile Strength Stainless Steel Cable Ties	cable tie	1	16 per plot x 3 plots = 48/2yrs = 24	\$0.29	pk 100	\$28.55	1	\$11.34	\$16.90	\$56.79	<a href="https://www.cabletiesandmore.com/stainless-steel-cable-ties?pid=58">https://www.cabletiesandmore.com/stainless-steel-cable-ties?pid=58</a>
Subtotal Materials										\$146.39	
<i>Labor</i>											
Mowing/Weeding Twice per Year After First Year	day	1	0.25 day per site x 2 months = 0.5 days	\$17/hr x 8 hr = \$136	1	\$136.00	0.5			\$68.00	Estimate 7 days
<b>Total Maintenance Cost per 900 ft (1 site = 150 ft x 6)</b>										<b>\$214.39</b>	
<b>Total Maintenance Cost per ft</b>										<b>\$0.48</b>	



P.O. Box 938  
 Round Rock, TX 78680  
 (512) 388-0588  
 (512) 388-0417 Fax  
 www.txcorr.com

**QUOTE**

- Grates
- Sign Post
- Geotextiles
- Bridge Railing
- Metal Fabrication
- Safety Pipe Runners
- Corrugated Steel Pipe
- Cast Iron Rings & Covers
- Metal Beam Guard Fence

<p><b>TEXAS A&amp;M UNIVERSITY</b></p> <p><b>ATTN: JAMES L. TRACY</b></p>	<p><b>County:</b> TRIANGLE SLIPBASE PARTS</p> <p><b>Highway:</b></p> <p><b>Control:</b> ***REVISED***</p> <p><b>Project:</b></p>
--	--

DESCRIPTION	UNIT	QUANTITY	PRICE	EXT
TRIANGLE SLIPBASE CASTING W/KEEPER PLATE & BOLTS	EA	220.00	42.00	\$9,240.00
3" X 3'-0" TRIANGLE STUB	EA	220.00	77.00	\$16,940.00
10BWG X 14' POSTS	EA	168.00	127.00	\$21,336.00
10BWG X 12' POSTS	EA	7.00	109.00	\$763.00
10BWG X 10' POSTS	EA	45.00	91.00	\$4,095.00
2.5" SIGN CLAMP ASSEMBLY	EA	59.00	3.39	\$200.01

NOTE: 1) DUE TO STEEL PRICE VOLATILITY, TEXAS CORRUGATORS MAY NOT BE ABLE TO HOLD PRICES AFTER 30 DAYS FROM DATE OF QUOTE. CALL FOR REVISED PRICING IF ORDERING MATERIAL AFTER 30 DAYS.

<p>TERMS OF PAYMENT: NET 30 DAYS</p> <p>PRICES VALID FOR 30 DAYS</p> <p>SALES TAX NOT INCLUDED</p> <p>TOLERANCES: INDIVIDUAL PART: ±.25"; LINEAR: ±3" (CMP) &amp; ±.5" (RAIL, SIGN SUPPORT); ANGULAR: ± 1°</p> <p>Subject to being awarded the contract, we accept your proposal to furnish the job requirements at the unit prices quoted above</p> <p>_____                  Company Name</p> <p>_____                  Print Name</p> <p>_____                  Signature</p>	<p>DELIVERY: 2-3 WEEKS</p> <p>F.O.B. POINT: TRUCKS-JOBSITE</p> <p>PRICES INCLUDE FREIGHT FOR 1 LOADS DELIVERED TO JOBSITE. ADDITIONAL LOADS DUE TO CUSTOMER REQUESTING LESS THAN TRUCKLOAD QUANTITIES WILL BE CHARGED AT \$325.00 PER LOAD.</p> <p>Respectfully submitted,                  TEXAS CORRUGATORS-AUSTIN DIVISION, INC</p> <p>NAME: JIMMY MADDOX      Date: 2/14/2022</p>
--	---

**Figure F.1. Quote from Texas Corrugators (2/14/2022) for triangular slip base anchors, various lengths of 10 BWG 2 7/8" OD posts, and sign clamp assemblies.**

## REFERENCES

- Adler, L.S. 2000. Alkaloid uptake increases fitness in a hemiparasitic plant via reduced herbivory and increased pollination. *The American Naturalist*, 156(1): 92-99.
- Adler, L.S. 2003. Host species affects herbivory, pollination, and reproduction in experiments with parasitic *Castilleja*. *Ecology*, 84(8): 2083-2091.
- Agrawal, A.A., and Inamine, H. 2018. Mechanisms behind the monarch's decline. *Science*, 360(6395): 1294–1296.
- Ajilvsgi, G. 2013. *Butterfly Gardening for Texas* (No. 46). Texas A&M University Press, College Station, Texas.
- American Association of State Highways and Transportation Officials [AASHTO]. 2004. *NCHRP Project 25-25(04): Environmental Stewardship Practices, Procedures, and Policies for Highway Construction and Maintenance*. AASHTO Center for Environmental Excellence. Accessed at: [http://www.trb.org/NotesDocs/25-25%284%29\\_FR.pdf](http://www.trb.org/NotesDocs/25-25%284%29_FR.pdf)
- American Meadows. 2015. *How to Germinate and Grow Milkweed Seed*. Williston, Vermont. Accessed at: <https://www.americanmeadows.com/blog/2015/06/11/how-to-germinate-and-grow-milkweed-seed>
- Anderson, J. B., & Brower, L. P. 1996. Freeze-protection of overwintering monarch butterflies in Mexico: critical role of the forest as a blanket and an umbrella. *Ecological Entomology*, 21(2):107–116. <https://doi.org/10.1111/j.1365-2311.1996.tb01177.x>
- Badgett, G., and Davis, A.K. 2015. Population trends of monarchs at a northern monitoring site: analyses of 19 years of fall migration counts at Peninsula Point, MI. *Annals of the Entomological Society of America*, 108: 700-706.
- Bager, A., and Fontoura, V. 2013. Evaluation of the effectiveness of a wildlife roadkill mitigation system in wetland habitat. *Ecological Engineering*, 53: 31-38.
- Barth, B. 2016. Sheet mulching: How to smother weeds, build soil, and conserve water the easy way. *Modern Farmer*, May 10 2016. Accessed at: <https://modernfarmer.com/2016/05/sheet-mulching/>
- Barthelmeß, E.L. 2014. Spatial distribution of road-kills and factors influencing road mortality for mammals in Northern New York State. *Biodiversity and Conservation*, 23(10):2491-2514.



- Baum, K.A. and Mueller, E.K. 2015. Grassland and roadside management practices affect milkweed abundance and opportunities for monarch recruitment. In: Oberhauser, K.S., Nail, K.R., and Altizer, S. (eds.), *Monarchs in a Changing World: Biology and Conservation of an Iconic Butterfly*, Cornell University Press, Ithaca, New York, pp.197-202.
- Baum K.A. and Sharber W.V. 2012. Fire creates host plant patches for monarch butterflies. *Biology Letters*, 8:968-971.
- Baxter-Gilbert, J.H., Riley, J.L., Neufeld, C.J., Litzgus, J.D., and Lesbarrères, D. 2015. Road mortality potentially responsible for billions of pollinating insect deaths annually. *Journal of Insect Conservation*, 19(5): 1029–1035.
- Benten, A., Hothorn, T., Vor, T., and Ammer, C. 2018. Wildlife warning reflectors do not mitigate wildlife–vehicle collisions on roads. *Accident Analysis & Prevention*, 120: 64-73.
- Bissonette, J.A. and Cramer, P.C. 2008. *Evaluation of the Use and Effectiveness of Wildlife Crossings*. National Cooperative Highway Research Program Report No. 615. Transportation Research Board, Washington, D.C. Accessed at: [http://www.roadsandwildlife.org/data/files/Documents/Evaluation%20of%20the%20Use%20and%20Effectiveness%20of%20Wildlife%20Crossings%20\(1\).pdf](http://www.roadsandwildlife.org/data/files/Documents/Evaluation%20of%20the%20Use%20and%20Effectiveness%20of%20Wildlife%20Crossings%20(1).pdf)
- Bond, A.R. and Jones, D.N. 2013. Wildlife warning signs: public assessment of components, placement and designs to optimise driver response. *Animals*, 3(4):1142-1161.
- Borders B., and Lee-Mäder, E. 2014. *Milkweeds: A Conservation Practitioner's Guide; Plant Ecology, Seed Production Methods, and Habitat Restoration Opportunities*. The Xerces Society for Invertebrate Conservation, Portland, Oregon, 156 pp, Accessed at: <http://www.xerces.org/milkweeds-a-conservation-practitioners-guide/>
- Borders B., and Lee-Mäder, E. 2015. Project Milkweed: A strategy for monarch conservation. In: Oberhauser, K.S., Nail, K.R., and Altizer, S. (eds.), *Monarchs in a Changing World: Biology and Conservation of an Iconic Butterfly*, Cornell University Press, Ithaca, New York, pp. 190-196.
- Bradley, C. A., & Altizer, S. 2005. Parasites hinder monarch butterfly flight: Implications for disease spread in migratory hosts. *Ecology Letters*, 8(3):290–300. <https://doi.org/10.1111/j.1461-0248.2005.00722.x>
- Bravo, A. and Porzecanski, A.L. 2018. Applying critical thinking to the amphibian decline problem. *Lessons in Conservation*, 8: 44-53.
- Brown, S.H. and Coopridger, K. 2011. *Baccharis halimifolia*. Fact Sheet. University of Florida, Institute of Food and Agricultural Sciences, Lee County Extension, Fort

- Myers, Florida, 5 pp. Available at:  
[http://lee.ifas.ufl.edu/Hort/GardenPubsAZ/Saltbush\\_Baccharis\\_halimifolia.pdf](http://lee.ifas.ufl.edu/Hort/GardenPubsAZ/Saltbush_Baccharis_halimifolia.pdf)
- BugGuide. 2020. Record Number 841618 - [image of monarch] "feeding on Gray Golden Aster (*Heterotheca canescens*)", 10 September 2013, Somervell County, Texas. Accessed at: <https://bugguide.net/node/view/841618>
- Bush, E. 2018. 'It's a long time coming': \$6.2 million wildlife bridge over I-90 nears completion. *Seattle Times*, 25 September, 2018. Accessed at: [https://www.seattletimes.com/seattle-news/its-a-long-time-coming-6-2-million-wildlife-bridge-over-i-90-nears-completion/?utm\\_source=twitter&utm\\_medium=social&utm\\_campaign=article\\_left\\_1.1](https://www.seattletimes.com/seattle-news/its-a-long-time-coming-6-2-million-wildlife-bridge-over-i-90-nears-completion/?utm_source=twitter&utm_medium=social&utm_campaign=article_left_1.1)
- Butterfly-Conservation.org. 2019. *Holly Blue* *Celastrina argiolus*. Accessed at: <https://butterfly-conservation.org/butterflies/holly-blue>
- CarolinaNature.com. 2019. *Appalachian Grizzled Skipper* (*Pyrgus [centaureae] wyandot*). Accessed at: <http://www.carolinanature.com/butterflies/grizzledskipper.html>
- Chung, E. 2014. Banff bears use trans-Canada wildlife crossings to find mates: Wildlife crossings can cost up to \$4 million each, but benefit bear populations. *Animal Road Crossing (ARC) News and Media*, 18 February, 2014. Accessed at: <https://arc-solutions.org/article/banff-bears-use-trans-canada-wildlife-crossings-to-find-mates-wildlife-crossings-can-cost-up-to-4m-each-but-benefit-bear-populations/>
- Ciocheti, G., de Assis, J.C., Ribeiro, J.W. and Ribeiro, M.C. 2017. Highway widening and underpass effects on vertebrate road mortality. *Biotropica*, 49(6): 765-769.
- Clevenger, A.P. and Kociolek, A.V. 2013. Potential impacts of highway median barriers on wildlife: State of the practice and gap analysis. *Environmental Management*, 52(5): 1299-1312.
- Collinson, W.J., Marneweck, C. and Davies-Mostert, H.T. 2019. Protecting the protected: reducing wildlife roadkill in protected areas. *Animal Conservation*, 22: 396-403.
- Coulson, G., and Bender, H. 2019. Roadkill mitigation is paved with good intentions: a critique of Fox *et al.* (2019). *Australian Mammalogy*, <https://doi.org/10.1071/AM19009>
- Cramer, P., and Flower, J. 2017. *Testing New Technology to Restrict Wildlife Access to Highways: Phase 1*. Utah DOT, Salt Lake City, Utah. Accessed at: <http://www.udot.utah.gov/main/uconowner.gf?n=37026229956376505>
- Cunningham, D. 2017. Put away the tiller and try earth-friendly sheet mulching for garden beds. *The Dallas Morning News*, 28 June 2017. Accessed at:

<https://www.dallasnews.com/arts-entertainment/2017/06/28/put-away-the-tiller-and-try-earth-friendly-sheet-mulching-for-garden-beds/>

- Davey, N., Dunstall, S. and Halgamuge, S. 2017. Optimal road design through ecologically sensitive areas considering animal migration dynamics. *Transportation Research Part C: Emerging Technologies*, 77: 478-494.
- Davey, N., Dunstall, S. and Halgamuge, S. 2018. The value of flexible road designs through ecologically sensitive areas. In: Sarker, R., Abbass, H.A., Dunstall, S. Kilby, P. Davis, R., and Young, L. (eds), *Data and Decision Sciences in Action*. Springer, Cham, Switzerland, pp. 71-80.
- Davis, A. 2017. Summary and comments on the 2016 study on the suitability of roadside habitat for monarchs. *The Science of Monarch Butterflies* (Blog). 18 September, 2017. Accessed at: <http://akdavis6.wixsite.com/monarchscience/single-post/2017/09/18/Summary-and-comments-on-the-2016-study-on-the-suitability-of-roadside-habitat-for-monarchs>
- Davis, A. K., Chi, J., Bradley, C., & Altizer, S. 2012. The Redder the Better: Wing Color Predicts Flight Performance in Monarch Butterflies. *PLoS ONE*, 7(7):e41323. <https://doi.org/10.1371/journal.pone.0041323>
- Dean, K. 2015. East Texas wildflowers to peak in next 2 weeks. *Tyler Morning Telegraph*, 4 May, 2015. Accessed at: [https://tylerpaper.com/news/local/east-texas-wildflowers-to-peak-in-next-weeks/article\\_4ccea25f-eb72-53a6-ad70-a3135f589526.html](https://tylerpaper.com/news/local/east-texas-wildflowers-to-peak-in-next-weeks/article_4ccea25f-eb72-53a6-ad70-a3135f589526.html)
- Dee J.R., Thomas, S.M., Thompson, S.D., and Palmer, M.W. 2016. Long-term late season mowing maintains diversity in southern US tallgrass prairie invaded by *Bothriochloa ischaemum*. *Applied Vegetation Science*, 19:442-453.
- Diboll, N. (2012) Site preparation and prairie seeding methods. White Paper, Prairie Nursery, Westfield, Wisconsin. Accessed at: <https://www.prairienursery.com/media/pdf/site-preparation-and-prairie-seeding-methods.pdf>
- Di Fonzo, M., Collen, B., Mace, G.M. 2013. A new method for identifying rapid decline dynamics in wild vertebrate populations. *Ecological Evolution*, 3: 2378–2391.
- Nature.com. 2019. *Green-veined White Butterfly- *Pieris napi**. Accessed at: <https://www.first-nature.com/insects/lb-pieris-napi.php>
- FarmersFriend.com. 2018. *How long is the shade cloth rated to last?* Accessed at: <https://support.farmersfriend.com/kb/article/45-how-long-is-the-shade-cloth-rated-to-last/>

- Fitzgerald, P. 2015. *Monarch Conservation in America's Cities: A Solutions Guide for Municipal Leaders*. National Wildlife Federation, 36 pp, Accessed at: [http://www.nwf.org/~media/PDFs/Garden-for-Wildlife/Monarch-Conservation-in-Americas-Cities\\_Guide-121715.pdf](http://www.nwf.org/~media/PDFs/Garden-for-Wildlife/Monarch-Conservation-in-Americas-Cities_Guide-121715.pdf)
- Flockhart, D. T. T., Wassenaar, L. I., Martin, T. G., Hobson, K. A., Wunder, M. B., & Norris, D. R. 2013. Tracking multi-generational colonization of the breeding grounds by monarch butterflies in eastern North America. *Proceedings of the Royal Society B: Biological Sciences*, 280(1768):20131087. <https://doi.org/10.1098/rspb.2013.1087>
- Forman, R.T.T., Freidman, D.S., Fitzhenry, D., Martin, J.D., Chen, A.S., and Alexander, L.E. 1997. Ecological effects of roads: toward three summary indices and an overview for North America. In: Canters, K. (ed.), *Habitat Fragmentation and Infrastructure, Proceedings of the International Conference on Habitat Fragmentation, Infrastructure and the Role of Ecological Engineering*, 17-21 September, 1995, Maastricht and the Hague, Netherlands. Ministry of Transport, Public Works and Water Management, Road and Hydraulic Engineering Division, Delft, Netherlands, pp. 40–54.
- Fox, S., Potts, J.M., Pemberton, D., and Crosswell, D. 2019. Roadkill mitigation: trialing virtual fence devices on the west coast of Tasmania. *Australian Mammalogy*, 45: 205-211 <https://doi.org/10.1071/AM18012>
- Gaga.biodiv.tw. 2019. *Euploea sylvester swinhoi* Wallace and Moore, 1866. Accessed at: <http://gaga.biodiv.tw/new23/000x/s3-112.htm>
- Garcia-Gonzalez, C., Campo, D., Pola, I.G. and Garcia-Vazquez, E. 2012. Rural road networks as barriers to gene flow for amphibians: species-dependent mitigation by traffic calming. *Landscape and Urban Planning*, 104(2): 171-180.
- Garren-McKillip, L. 2016. Native vs tropical milkweed. *Gulf Coast Gardening*, 201: 7. Accessed at: [https://aggie-horticulture.tamu.edu/galveston/GCMG\\_Newsletters/201\\_July-August\\_2016\\_MG\\_Newsletter\\_Large.pdf](https://aggie-horticulture.tamu.edu/galveston/GCMG_Newsletters/201_July-August_2016_MG_Newsletter_Large.pdf)
- GBIF.org. 2019. *Asclepias curassavica*. Global Biodiversity Information System, Copenhagen, Denmark. Accessed at: <https://www.gbif.org/species/3170241>
- Gearino, J. 2009. G&F [Game and Fish] sees underpass success. *Casper Star Tribune*, 14 December, 2009. Accessed at: [https://trib.com/news/state-and-regional/g-f-sees-underpass-success/article\\_9a0f9760-069b-53ab-997f-6ae4b6f78c1c.html](https://trib.com/news/state-and-regional/g-f-sees-underpass-success/article_9a0f9760-069b-53ab-997f-6ae4b6f78c1c.html)
- Georgii, B., Keller, V., Pfister, H.P., Reck, H., Peters-Ostenberg, E., Henneberg, M., Herrmann, M., Mueller-Stiess, H. and Bach, L. 2011. Use of wildlife passages by invertebrate and vertebrate species. *Wildlife Passages in Germany, 2011*. Accessed

at: <http://www.forumochranyprirody.cz/sites/default/files/zahranicni-inspirace/gruenbruecke11.pdf>

- Glista, D.J., DeVault, T.L., and DeWoody, J.A. 2008. Vertebrate road mortality predominantly impacts amphibians. *Herpetological Conservation and Biology*, 3(1): 77-87.
- Glista, D.J., DeVault, T.L., and DeWoody, J.A. 2009. A review of mitigation measures for reducing wildlife mortality on roadways. *Landscape and Urban Planning*, 91(1): 1-7.
- Google Maps. 2019. *Street and Satellite Views*. Google Inc., Mountain View, California. Accessed at: <https://www.google.com/maps?hl=en&tab=rl>
- Goosem, M., 2009. Rethinking road ecology. In: Stork, N.E. and Turben, S.M. (eds.), *Living in a Dynamic Tropical Forest Landscape*, Blackwell Publishing, Malden, Massachusetts, pp. 445-459.
- Grant, E.H.C., Muths, E., Schmidt, B.R. and Petrovan, S.O. 2019. Amphibian conservation in the Anthropocene. *Biological Conservation*, 236: 543-547.
- Grant, T.J., Parry, H.R., Zalucki, M.P. and Bradbury, S.P. 2018. Predicting monarch butterfly (*Danaus plexippus*) movement and egg-laying with a spatially-explicit agent-based model: The role of monarch perceptual range and spatial memory. *Ecological Modelling*, 374: 37-50.
- Gray, M. 2009. Advances in wildlife crossing technologies. *Public Roads (FHWA-HRT-09-006)*, 73(2). Accessed at: <https://www.fhwa.dot.gov/publications/publicroads/09septoct/03.cfm>
- Hallmann, C.A., Sorg, M., Jongejans, E., Siepel, H., Hofland, N., Schwan, H., Stenmans, W., Müller, A., Sumser, H., Hörren, T. and Goulson, D. 2017. More than 75 percent decline over 27 years in total flying insect biomass in protected areas. *PLoS ONE*, 12 (10): e0185809. Accessed at: <https://journals.plos.org/plosone/article/file?id=10.1371/journal.pone.0185809&type=printable>
- Helldin, J.O., and Petrovan, S.O. 2019. Effectiveness of small road tunnels and fences in reducing amphibian roadkill and barrier effects; case studies of retrofitted roads in Sweden. *PeerJ Preprints*, DOI 10.7717/peerj.7518. Accessed at: <https://peerj.com/preprints/27530.pdf>
- Her, K. 2008. Ensuring a Safe Journey. *Taiwan Today, Taiwan Review*, 1 August, 2008. Accessed at: <http://taiwantoday.tw/news.php?post=23836&unit=14,29,34,45>



- Herrera, C.M. 2019. Complex long-term dynamics of pollinator abundance in undisturbed Mediterranean montane habitats over two decades. *Ecological Monographs*, 89(1): e01338.
- Hels, T. and Buchwald, E., 2001. The effect of road kills on amphibian populations. *Biological Conservation*, 99(3):331-340.
- Highways England. 2018. A556 'green bridge' is winter wonderland. *Highways England*, 10 January 2018. United Kingdom Government, London, United Kingdom. Accessed at: <https://www.gov.uk/government/news/a556-green-bridge-is-winter-wonderland>
- Hobday, A.J. and Minstrell, M.L. 2008. Distribution and abundance of roadkill on Tasmanian highways: human management options. *Wildlife Research*, 35(7):712-726.
- Hopwood, J., Black, S.H., Lee-Mäder, Charlap, A., Preston, R., Mozumber, K., Fleury, S. 2015. *Literature Review: Pollinator Habitat Enhancement and Best Management Practices in Highway Rights-of-Way*. Xerces Society for Invertebrate Conservation for U.S. Department of Transportation Federal Highway Administration, Washington, D.C. Accessed at: [http://www.xerces.org/wp-content/uploads/2015/12/pollinators\\_BMPs\\_in\\_highway\\_ROW.pdf](http://www.xerces.org/wp-content/uploads/2015/12/pollinators_BMPs_in_highway_ROW.pdf)
- Huijser, M.P., Mosler-Berger, C., Olsson, M., and Strein, M. 2015. Wildlife warning signs and animal detection systems aimed at reducing wildlife-vehicle collisions. In: Van der Ree, R., Smith, D.J., and Grilo, C., (eds.), *Handbook of Road Ecology*. John Willey & Sons Ltd., West Sussex, United Kingdom, pp. 198-212.
- iNaturalist.org. 2021. *Search*. [Search individual species for distribution records, images, and flower phenology graphs]. Accessed at: <https://www.inaturalist.org/>
- Iuell, B., Bekker, H., Cuperus, R., Dufek, J., Fry, G., Hicks, C., Hlaváč, V., Keller, V., Rosell, C., Sangwine, T., Tørsløv, N., and Wandall, B. 2011. *COST 341 Habitat Fragmentation due to Transportation Infrastructure: Wildlife and Traffic; A European Handbook for Identifying Conflicts and Designing Solutions*. European Co-operation in the Field of Scientific and Technical Research, Brussels, Germany. Accessed at: [http://www.iene.info/wp-content/uploads/COST341\\_Handbook.pdf](http://www.iene.info/wp-content/uploads/COST341_Handbook.pdf)
- Jaarsma, C.F. 1997. Approaches for the planning of rural road networks according to sustainable land use planning. *Landscape and Urban Planning*, 39(1): 47-54.
- Jaarsma, C.F., van Langevelde, F. and Botma, H. 2006. Flattened fauna and mitigation: traffic victims related to road, traffic, vehicle, and species characteristics. *Transportation Research Part D: Transport and Environment*, 11(4):.264-276.

- Jacobson, S.L. 2005. Mitigation measures for highway-caused impacts to birds. In: Ralph, C.J., Rich, T.D. (eds.), *Bird Conservation Implementation and Integration in the Americas: Proceedings of the Third International Partners in Flight Conference*, Volume 2, March 20-24, 2002, Asilomar, California. USDA Forest Service, General Technical Report PSW-GTR-191, Albany, California. California, pp. 1043-1050. Accessed at: <https://www.fs.usda.gov/treearch/pubs/download/32104.pdf>
- Jakobsson, S., Bernes, C., Bullock, J.M., Verheyen, K. and Lindborg, R. 2018. How does roadside vegetation management affect the diversity of vascular plants and invertebrates? A systematic review. *Environmental Evidence*, 7.
- Jankowska, B., Poniedziałek, M., and Jędrszczyk, E. 2009. Effect of intercropping white cabbage with French marigold (*Tagetes patula nana* L.) and pot marigold (*Calendula officinalis* L.) on the colonization of plants by pest insects. *Folia Horticulturae*, 21(1): 95-103.
- Jensen, A.J. 2018. *Crossing Corridors: Wildlife Use of Jumpouts and Undercrossings along a Highway with Wildlife Exclusion Fencing*. Master's Thesis, California Polytechnic State University, San Luis Obispo, California. Accessed at: <https://pdfs.semanticscholar.org/d08e/1f40232ac74ef33ae5d4da9a154f012c4b38.pdf>
- Jiang, N., Cramer, P., Loftus-Otway, L. 2019. *White Paper: The Incorporation of Wildlife Crossing Structures into TxDOT's Projects and Operations*. TxDOT Project Number 0-6971, Texas DOT, Austin, Texas. Accessed at: <https://library.ctr.utexas.edu/ctr-publications/0-6971-p1.pdf>
- JohnDeere.com. 2019. How to plant a wildflower meadow. *Tips Notebook*. Accessed at: <https://tipsnotebook.deere.com/planting-wildflowers/>
- Johnston, M.K., Hasle, E.M., Klinger, K.R., Lambruschi, M.P., Derby Lewis, A., Stotz, D.F., Winter, A.M., Bouman, M.J., and Redlinski, I. 2019. Estimating milkweed abundance in metropolitan areas under existing and user-defined scenarios. *Frontiers in Ecology and Evolution*, 7: 210.
- Jones, D. and Bond, A.F. 2010. Road barrier effect on small birds removed by vegetated overpass in South East Queensland. *Ecological Management and Restoration*, 11(1): 65-67.
- Journey North. 2019. *Monarch Butterflies: Spring Migration Archives*. Accessed at: <https://journeynorth.org/tm/monarch/MigrationMaps.html>
- Journey North. 2020. *Spring 2020 Maps: Monarch Adult Sighted*. Accessed at: <https://maps.journeynorth.org/map/?map=monarch-adult-spring&year=2020>

- Kantola T., Tracy J.L., Baum K.A., Quinn M.A., and Coulson R.N. 2019. Spatial risk assessment of eastern monarch butterfly road mortality during autumn migration within the southern corridor. *Biological Conservation*, 231: 150-160.
- Kantola T., Tracy J.L., Baum K.A., and Coulson R.N. In prep. Monarch spring and fall nectar plant habitat models and land cover risk assessment.
- Kartesz, J.T. 2015. *North American Plant Atlas*. The Biota of North America Program (BONAP), Chapel Hill, N.C. [maps generated from Kartesz, J.T. 2015. Floristic Synthesis of North America, Version 1.0. Biota of North America Program (BONAP). (in press)]. Available at <http://bonap.net/NAPA/TaxonMaps/Genus/County/>
- Kasten, K., Stenoien, C., Caldwell, W. and Oberhauser, K.S. 2016. Can roadside habitat lead monarchs on a route to recovery?. *Journal of Insect Conservation*, 20(6):1047-1057.
- Keilsohn, W., Narango, D.L. and Tallamy, D.W. 2018. Roadside habitat impacts insect traffic mortality. *Journal of Insect Conservation*, 22(2): 183-188.
- Keller, V., Bauer, H.G., Ley, H.W. and Pfister, H.P. 1996. Importance of green bridges over highways for birds. *The Ornithological Observer*, 93: .249-258. (In German).
- Kelley, R, 2017. Ocelot barriers going in at FM 106 underpass. *Valley Star* (Harlingen, Texas), 16 March, 2017. Accessed at: <https://www.valleymorningstar.com/2017/03/16/ocelot-barriers-going-in-at-fm-106-underpasses/>
- Kelley, R, 2018. Cat crossroads: Experts say ocelots need time to adjust to underpass. *The Monitor* (McAllen, Texas), 8 April, 2018. Accessed at: <https://www.themonitor.com/2018/04/08/cat-crossroads-experts-say-ocelots-need-time-to-adjust-to-underpasses/>
- Kincaid, D. 2013. Linking highway infrastructure projects with wildlife and open space conservation efforts. Case study: U.S. Rt. 33 Nelsonville by-pass, Wayne National Forest Ohio. In: *Planning for Growth and Open Space Conservation Webinar Series; Session 12; Greening Grey Infrastructure: Federal Highway Administration's Ecological Approach and Case Studies from National Forests in Ohio and Washington*, USDA Forest Service, Washington, DC. Accessed at: [https://www.fs.fed.us/openspace/webinar-pdfs/FINAL\\_SESSION%2012%20Eco\\_Logical%20and%20Highways.pdf](https://www.fs.fed.us/openspace/webinar-pdfs/FINAL_SESSION%2012%20Eco_Logical%20and%20Highways.pdf) (pdf presentation); <http://connect.clemson.edu/p8agpmltvhy/> (video presentation, 30:45-32:09)
- Kislingbury, G. 2013. Fender's blue on the rise. *Corvallis Gazette-Times*, 16 June, 2013. Accessed at: <https://www.gazettetimes.com/oregon-outdoors/watchable->

[wildlife/fender-s-blue-on-the-rise/article/8e123784-3149-5cac-9b2b-7b14a309bf56.html](https://wildlife/fender-s-blue-on-the-rise/article/8e123784-3149-5cac-9b2b-7b14a309bf56.html)

- Klamath-Siskiyou Seeds. 2015. *Native Monarch Butterfly Nectar Plants in the Klamath-Siskiyou*. Accessed at: <https://klamathsiskiyouseeds.com/2015/10/18/native-monarch-butterfly-nectar-plants-in-the-klamath-siskiyou/>
- Knight, S.M., Norris, D.R., Derbyshire, R. and Flockhart, D.T. 2019. Strategic mowing of roadside milkweeds increases monarch butterfly oviposition. *Global Ecology and Conservation*, 19:e00678.
- Lady Bird Johnson Wildflower Center. 2016. *Plant Database*. University of Texas at Austin, Austin, Texas. Accessed at: <https://www.wildflower.org/plants-main>
- Lady Bird Johnson Wildflower Center. 2018. *How to Germinate Milkweeds*. University of Texas at Austin, Texas. Accessed at: <https://www.wildflower.org/learn/how-to/how-to-germinate-milkweeds#:~:text=Soak%20milkweed%20seeds%20in%20water,for%20at%20least%20two%20weeks.>
- Lewis, A.D., Bouman, M.J., Winter, A., Hasle, E., Stotz, D., Johnston, M.K., and Czarnecki, C. 2019. Does Nature Need Cities? Pollinators Reveal a Role for Cities in Wildlife Conservation. *Frontiers in Ecology and Evolution*, 7: 220.
- Li, C.L. 2014. Bridging a forest: Animal crossing that reduce the peril of roads. *Star Online*, 22 September, 2014. Accessed at: <https://www.thestar.com.my/news/environment/2014/09/22/bridging-a-forest-animal-crossings-that-reduce-the-perils-of-the-roads>
- Legacy Habitat Management Limited. 2019. *Amphibian Climate Tunnel*. Legacy Habitat Management Limited, Sheffield, United Kingdom. Accessed at: <https://www.legacy-habitat.co.uk/amphibian-climate-tunnel.html>
- Lehman, R., and Ross, S. 2018. Tasmanian conservation groups launch fresh drive to cut roadkill on state's roads. *Mobile.abc.net.au News* [Australian Broadcasting Corporation, Sydney, Australia], 19 January, 2018. Accessed at: <https://mobile.abc.net.au/news/2018-01-18/campaign-to-cut-roadkill-toll-in-tasmania/9338678?pfmredir=sm&pfm=sm>
- Lester, D. 2015. Effective wildlife roadkill mitigation. *Journal of Traffic and Transportation Engineering*, 3: 42-51.
- Lister, B.C., and Garcia, A. 2018. Climate-driven declines in arthropod abundance restructure a rainforest food web. *Proceedings of the National Academy of Sciences*, 115(44): E10397-E10406.

- Litvaitis, J.A. and Tash, J.P. 2008. An approach toward understanding wildlife-vehicle collisions. *Environmental Management*, 42(4):688-697.
- Lloyd, Z.A. 2012. Nelsonville bypass teaches state to build eco-conscious road. *Zachary A. Lloyd Blog*, 28 September, 2012. Accessed at: <https://zacharylloyd.wordpress.com/2012/09/28/nelsonville-bypass-teaches-state-to-build-eco-conscious-road/>
- Loss, S.R., Will, T., and Marra, P.P. 2014. Estimation of bird-vehicle collision mortality on US roads. *The Journal of Wildlife Management*, 78(5): 763-771.
- Loss, S.R., Will, T. and Marra, P.P. 2015. Direct mortality of birds from anthropogenic causes. *Annual Review of Ecology, Evolution, and Systematics*, 46: 99-120.
- Luna T., and Karsten Dumroese, R. 2013. Monarchs (*Danaus plexippus*) and milkweeds (*Asclepias* species): The current situation and methods for propagating milkweeds. *Native Plants*, 14:5-15.
- Malo, J.E., Suárez, F. and Diez, A. 2004. Can we mitigate animal-vehicle accidents using predictive models? *Journal of Applied Ecology*, 41(4): 701-710.
- Markwardt, D. 2018. TxDOT Monarch Activities. In: *2018 TxDOT Environmental Conference*, 11-13 September, 2018, Dallas, Texas, Texas A&M Transportation Institute, College Station, Texas, Presentation. Accessed at: <http://static.tti.tamu.edu/conferences/envr18/presentations/general/markwardt.pdf>
- Matador Wildlife Management Area. 2018. *Facebook Post*, 30 September, 2018. Accessed at: <https://www.facebook.com/MatadorWMA/posts/thousands-of-monarch-butterflies-are-migrating-through-the-wma-on-thier-way-to-t/1091654534326178/>
- McKenna, D.D., McKenna, K.M., Malcom, S.B., and Berenbaum, M.R. 2001. Mortality of Lepidoptera along roadways in central Illinois. *Journal of Lepidopterist's Society*, 55 (2): 63-68.
- Milton, S.J., Dean, W.R.J., Sielecki, L.E., and van der Ree, R. 2015. The function and management of roadside vegetation. In: Van der Ree, R., Smith, D.J., and Grilo, C., (eds.), *Handbook of Road Ecology*. John Willey & Sons Ltd., West Sussex, United Kingdom, pp. 373-381.
- Monarch Candidate Conservation Agreement with Assurances and Candidate Conservation Agreement [CCAA/CCA] Development Team. 2020. *Nationwide Candidate Conservation Agreement for monarch butterfly on energy and transportation lands: An integrated Candidate Conservation Agreement with Assurances (CCAA) and Candidate Conservation Agreement (CCA)*. Energy Resources Center at The University of Illinois at Chicago, Chicago, Illinois. Accessed at:



[https://wwwfwsgov/savethemonarch/pdfs/Final\\_CCAA\\_040720\\_Fully%20Executedpdf](https://wwwfwsgov/savethemonarch/pdfs/Final_CCAA_040720_Fully%20Executedpdf)

- Monarch Joint Venture. 2016. *Mowing: Best Practices for Monarchs*. University of Minnesota, Department of Fisheries, Wildlife, and Conservation Biology, St. Paul, Minnesota. Accessed at: <https://monarchjointventure.org/images/uploads/documents/MowingForMonarchs.pdf>
- Monarch Joint Venture. 2017a. *Monarch Conservation Implementation Plan*. 27 pp, Accessed at: [http://monarchjointventure.org/images/uploads/documents/2017\\_MJV\\_Implementation\\_Plan\\_FINAL.pdf](http://monarchjointventure.org/images/uploads/documents/2017_MJV_Implementation_Plan_FINAL.pdf)
- Monarch Joint Venture. 2017b. *Setting targets for milkweed stem density*. Accessed at: <https://monarchjointventure.org/news-events/partner-memos/setting-targets-for-milkweed-stem-density>
- Monarch Joint Venture. 2019a. *What is the most appropriate time to cut tropical milkweed back?* Accessed at: <https://monarchjointventure.org/resources/faq/when-to-cut-back-tropical-milkweed>
- Monarch Joint Venture. 2019b. *Department of Transportation*. Accessed at: <https://monarchjointventure.org/i-am-a/departament-of-transportation>
- Monarch Joint Venture. 2020. *Annual Life Cycle*. Accessed at: <https://monarchjointventure.org/monarch-biology/annual-life-cycle>
- Monarch Watch. 2017. *Free Milkweeds for Restoration Projects*. Accessed at: <http://monarchwatch.org/bring-back-the-monarchs/milkweed/free-milkweeds-for-restoration-projects/>
- Monarch Watch. 2019. Monarch Population Status. *Monarch Watch Blog*, 30 January 2019. Accessed at: <https://monarchwatch.org/blog/2019/01/30/monarch-population-status-37/>
- Monarch Watch. 2021. *How many [Milkweed] Plugs Should I Plant?* Milkweed Market Article. Accessed at: <http://support.milkweedmarket.org/kb/article/355-how-many-plugs-should-i-plant/>
- Monarch Watch. 2022. *Milkweed Propagation (Growing Milkweeds)*. Accessed at: <https://monarchwatch.org/milkweed/prop.htm>
- Mora Alvarez, B.X., Carrera-Treviño, R., and Hobson, K.A. 2019. Mortality of monarch butterflies (*Danaus plexippus*) at two highway crossing “hotspots” during autumn migration in Northeast Mexico. *Frontiers in Ecology and Evolution*, 7: 273.

- Nail, K.R., Stenoien, C. and Oberhauser, K.S, 2015. Immature monarch survival: effects of site characteristics, density, and time. *Annals of the Entomological Society of America*, 108: 680-690.
- National Oceanic and Atmospheric Administration (NOAA). 2021. *Day of the Last Spring Freeze from the 1981-2010 U.S. Climate Normals*. Map. Accessed at: <https://www.ncdc.noaa.gov/file/day-last-spring-freeze-mapjpg>
- National Fish and Wildlife Foundation. 2020. *Monarch Butterfly and Pollinators Conservation Fund 2020 Request for Proposals*. Accessed at: <https://www.nfwf.org/programs/monarch-butterfly-and-pollinators-conservation-fund/monarch-butterfly-and-pollinators#:~:text=OVERVIEW,proposals%20to%20advance%20pollinator%20conservation.&text=The%20majority%20of%20funding%20will,pollinator%20species%20are%20also%20eligible>.
- Native Plant Information Network. 2022. *Find Plants*. Ladybird Johnson Wildflower Center, Austin, Texas. Accessed at: <http://www.wildflower.org/plants>
- Natural England. 2015. *Green Bridges: A Literature Review*. Natural England Commissioned Report NECR181. Natural England, Worcester, United Kingdom. Accessed at: <http://publications.naturalengland.org.uk/publication/6312886965108736>
- NatureServe.org. 2019. *Pyrgus wyandot* – W.H. Edwards, 1983. *An Online Encyclopedia of Life*. Accessed at: <http://explorer.natureserve.org/servlet/NatureServe?searchName=Pyrgus+wyandot>
- North Carolina Department of Transportation. 2020a. *Vegetation Management Section; Maintenance Programs; Threatened and Endangered Species*. Accessed at: <https://connect.ncdot.gov/resources/roadside/VegetationManagementDocuments/Threatened%20and%20Endangered%20Plant%20Species.pdf>
- North Carolina Department of Transportation. 2020b. *11.33 NCDOT Roadside Vegetation Management Guidelines to Marked Areas*. Accessed at: [http://environment.transportation.org/documents/nchrp25\\_25\\_files/appendices\\_33.pdf](http://environment.transportation.org/documents/nchrp25_25_files/appendices_33.pdf)
- Ohio Department of Transportation. 2015. *District 09 Bee Pollinator Habitats*. Accessed at: <http://www.dot.state.oh.us/districts/D09/Bee%20Pollinator%20Habitats/Forms/DispForm.aspx?ID=69>
- Ohio Department of Transportation. 2016. *Statewide Roadside Pollinator Habitat Program Restoration Guidelines and Best Management Practices*. Columbus, Ohio,

81 pp. Accessed at:

[http://www.davey.com/media/1619374/1\\_odot\\_statewide\\_roadside\\_pollinator\\_habitat\\_restoration\\_guide.pdf](http://www.davey.com/media/1619374/1_odot_statewide_roadside_pollinator_habitat_restoration_guide.pdf)

Ollerton, J. 2017. Pollinator diversity: distribution, ecological function, and conservation. *Annual Review of Ecology, Evolution, and Systematics*, 48: 353-376.

Oregon Department of Transportation. 2015. *Oregon Department of Transportation Statewide Habitat Conservation Plan for Routine Maintenance Activities*. Salem, Oregon, 135 pp. Accessed at:  
[https://www.fws.gov/oregonfwo/Documents/ODOT\\_HCP0915.pdf](https://www.fws.gov/oregonfwo/Documents/ODOT_HCP0915.pdf)

Pelton, E.M., Schultz, C.B., Jepsen, S.J., Black, S.H. and Crone, E.E. 2019. Western monarch population plummets: Status, probable causes, and recommended conservation actions. *Frontiers in Ecology and Evolution*, 7: 258.

Phillips, B.B., Gaston, K.J., Bullock, J.M. and Osborne, J.L. 2019. Road verges support pollinators in agricultural landscapes, but are diminished by heavy traffic and summer cutting. *Journal of Applied Ecology*. DOI: 10.1111/1365-2664.13470

Pierce, S.D. 2019. New \$5 million, animals-only overpass at Parleys Summit is saving wildlife (and drivers) already. *The Salt Lake Tribune*, 20 June, 2019. Accessed at:  
<https://www.sltrib.com/news/2019/06/20/new-million-animals-only/>

Pomeroy, D. 2017. Ocelot crossing sign. *Flickr.com*, 13 November 2017. Accessed at:  
<https://www.flickr.com/photos/dpom12/23867678867/>

Rao, R.S.P. and Girish, M.S. 2007. Road kills: Assessing insect casualties using flagship taxon. *Current Science*, 92(60):830-837.

Reck, H., Rietze, J., and Hermann, G. 1997. Zoological studies at the Wuertembergle, Hohereute, Oberderdingen, and Hardt 3 green bridges. In: Pfister, H.P., Keller, V., Reck, H., and Georgii B (eds.), *Bio-ecological Effectiveness of Green Bridges over Transport Routes*. Research on Road Construction and Road Traffic Engineering, German Federal Ministry of Transport, Bonn-Bad Godesberg, Germany, 756: 469-492. (In German).

Rhodes, C.J. 2018. Pollinator decline—an ecological calamity in the making?. *Science Progress*, 101(2): 121-160.

Rhodes, C.J. 2019. Are insect species imperilled? Critical factors and prevailing evidence for a potential global loss of the entomofauna: A current commentary. *Science Progress*, 102(2): 181-196.

- Rosenberg, K.V., Dokter, A.M., Blancher, P.J., Sauer, J.R., Smith, A.C., Smith, P.A., Stanton, J.C., Panjabi, A., Helft, L., Parr, M. and Marra, P.P. 2019. Decline of the North American avifauna. *Science*, p.eaaw1313.
- Rytwinski, T., Soanes, K., Jaeger, J.A., Fahrig, L., Findlay, C.S., Houlahan, J., van Der Ree, R. and van der Grift, E.A. 2016. How effective is road mitigation at reducing road-kill? A meta-analysis. *PLoS ONE*, 11(11): e0166941. Accessed at: <https://journals.plos.org/plosone/article/file?id=10.1371/journal.pone.0166941&type=printable>
- Santiago-Chaparro, K.R., Chitturi, M., Bill, A. and Noyce, D.A. 2012. Spatial effectiveness of speed feedback signs. *Transportation Research Record*, 2281(1):8-15.
- Santhosh, S., and Basavarajappa, S. 2014. Road mortality of migrant butterflies [Nymphalidae: Danaiane] at National Highway-209 in Chamarajanagar District of Karnataka, India. *Indian Journal of Applied Research*, 4: 553–557. Accessed at: [https://www.worldwidejournals.com/indian-journal-of-applied-research-\(IJAR\)/fileview.php?val=September\\_2014\\_1492849834\\_166.pdf](https://www.worldwidejournals.com/indian-journal-of-applied-research-(IJAR)/fileview.php?val=September_2014_1492849834_166.pdf)
- Satterfield, D.A., Maerz, J.C., Hunter, M.D., Flockhart, D.T., Hobson, K.A., Norris, D.R., Streit, H., de Roode, J.C. and Altizer, S. 2018. Migratory monarchs that encounter resident monarchs show life-history differences and higher rates of parasite infection. *Ecology Letters*, 21(11): 1670-1680.
- Schaal, B.A. 1980. Reproductive capacity and seed size in *Lupinus texensis*. *American Journal of Botany*, 67(5): 703-709.
- Schmidt, B.R., Zumbach, S. 2008. Amphibian road mortality and how to prevent it: A review. In: Mitchell, J.C., Jung Brown, R.E. and Bartolomew, B. (eds.), *Urban Herpetology*. Society for the Study of Amphibians and Reptiles, Salt Lake City, Utah, Herpetological Conservation No. 3, pp. 157-167. Accessed at: <https://www.zora.uzh.ch/id/eprint/10142/2/194V.pdf>
- Seyidova, S. 2019. Aurora's turtle crossing signs protect species: Turtles more active during nesting season. *YorkRegion.com*, 21 May, 2019. Accessed at: <https://www.yorkregion.com/community-story/9344387-aurora-s-turtle-crossing-signs-protect-species/>
- Silberglied, R.E. and Taylor, O.R. 1978. Ultraviolet reflection and its behavioral role in the courtship of the sulfur butterflies *Colias eurytheme* and *C. philodice* (Lepidoptera, Pieridae). *Behavioral Ecology and Sociobiology*, 3(3): 203-243.
- Simpson, N.O., Stewart, K.M., Schroeder, C., Cox, M., Huebner, K. and Wasley, T. 2016. Overpasses and underpasses: Effectiveness of crossing structures for migratory ungulates. *The Journal of Wildlife Management*, 80(8): 1370-1378.

- Singhurst J., Hutchins B., and Holmes W.C. 2015. *Identification of Milkweeds (Asclepias, Family Apocynaceae) in Texas*. Texas Parks and Wildlife and Lady Bird Johnson Wildflower Center, University of Texas, Austin, Texas. Accessed at: <https://www.wildflower.org/plants/TPWD-Identification-Milkweeds-Texas.pdf>
- Smith, D.J., van Der Ree, R. and Rosell, C. 2015. Wildlife crossing structures: an effective strategy to restore or maintain wildlife connectivity across roads. In: van der Ree, R., Smith, D.J., and Grilo, C., (eds.), *Handbook of Road Ecology*. John Willey & Sons Ltd., West Sussex, United Kingdom, pp.172-183.
- Stewart, J. 2017. Bridges for animals to safely cross freeways are popping up around the world. *My Modern Met*, 9 February 2019. Accessed at: <https://mymodernmet.com/wildlife-crossings/>
- Taiwan Area National Freeway Bureau. 2007. *Conservation – Purple Butterfly (National Road to Butterfly Road)*. Accessed at: <https://www.freeway.gov.tw/Centralarchives/publish.aspx?NID=2637&P=9192>
- Taiwan Area National Freeway Bureau. 2008. Special report on the safe migration of purple crow butterflies. In: *2008 Annual Report; Chapter 9 Investigation Trip Abroad and Research Report*, pp. 103-110. Accessed at: <https://www.freeway.gov.tw/UserFiles/File/Secretariat/2008annual/97CH9.pdf>
- Taiwan Area National Freeway Bureau. 2014. *2013 National Highway Purple Crow Butterfly Migration Survey and Conservation Work Report*. (In Chinese). Accessed at: <http://www.freeway.gov.tw/Upload/201506/%E7%94%9F%E6%85%8B%E4%BF%9D%E8%82%B2-%E5%9C%8B%E9%81%93%E8%99%9F%E7%B4%AB%E6%96%91%E8%9D%B6%E4%BF%9D%E8%82%B2.pdf>
- Taiwan Area National Freeway Bureau. 2015. *National Road No. 3 Nanyun Interchange Project Butterfly Monitoring Survey Report*. (In Chinese). Accessed at: <https://www.freeway.gov.tw/UserFiles/File/Widening/HistoryArea/GroupAndCulture/2-5-1-2ButterflySurveyReport.pdf>
- Taiwan Environmental Protection Administration. 2010. Environmental inspection: highways yield to flyways – EPA takes up butterfly conservation. *Environmental Policy Monthly* (Environmental Protection Administration, Republic of China [Taiwan]). 13. pp. 9–10. Accessed at: <https://www.epa.gov.tw/cpDownloadCtl.asp?id=61993>
- TAPCONet.com. 2019. *Wildlife warning BlinkerSign*. Accessed at: <https://www.tapconet.com/product/wildlife-warning-blinkersign>



- Tatar, M., and C.-M. Yin. 2001. Slow aging during insect reproductive diapause: why butterflies, grasshoppers and flies are like worms. *Experimental Gerontology*, 36:723–738.
- Taylor, O. R., Pleasants, J. M., Grundel, R., Pecoraro, S. D., Lovett, J. P., & Ryan, A. 2020. Evaluating the Migration Mortality Hypothesis Using Monarch Tagging Data. *Frontiers in Ecology and Evolution*, 8. <https://doi.org/10.3389/fevo.2020.00264>
- Texas Department of Transportation. 2003. *Solar Powered Roadside Flashing Beacon Assembly Details*. SPRFBA (1) -13. Accessed at: <ftp://ftp.dot.state.tx.us/pub/txdot-info/cmd/cserve/standard/traffic/spb1-13.pdf>
- Texas Department of Transportation. 2005. *Manual Notice 2005-1: Texas Reference Marker System User's Manual*. Accessed at: [http://onlinemanuals.txdot.gov/txdotmanuals/trm/manual\\_notice.htm](http://onlinemanuals.txdot.gov/txdotmanuals/trm/manual_notice.htm)
- Texas Department of Transportation. 2008. *Sign Mounting Details – Small Roadside Signs General Notes and Details*. SMD (GEN) – 08. Accessed at: <https://www.thc.texas.gov/public/upload/TxDOT%20sign%20installation%20standards.pdf>
- Texas Department of Transportation. 2014a. *Standard Specifications for Construction and Maintenance of Highways, Streets and Bridges: Item 164 Seeding for Erosion Control*. Accessed at: <https://ftp.txdot.gov/pub/txdot-info/cmd/cserve/specs/2014/standard/specbook-2014.pdf>
- Texas Department of Transportation. 2014b. *Sign Mount Details - Bridge Railing*. SMD (BR-1)-14. Accessed at: <https://ftp.dot.state.tx.us/pub/txdot-info/cmd/cserve/standard/traffic/smdbr-14.pdf>
- Texas Department of Transportation. 2014c. *Texas MUTCD Manual on Uniform Traffic Control Devices*. Revision 2, October 2014. Accessed at: <https://ftp.dot.state.tx.us/pub/txdot-info/trf/tmutcd/2011-rev-2/revision-2.pdf>
- Texas Department of Transportation. 2015. *Manual Notice 2015-1: Procedures for Establishing Speed Zones*. Accessed at: [http://onlinemanuals.dot.state.tx.us/txdotmanuals/szn/manual\\_notice.htm](http://onlinemanuals.dot.state.tx.us/txdotmanuals/szn/manual_notice.htm)
- Texas Department of Transportation. 2017. *Grass Seed Suppliers; Item 164 "Seeding for Erosion Control"*. TxDOT Maintenance Division, Austin, Texas. Accessed at: [https://ftp.dot.state.tx.us/pub/txdot-info/mnt/erosion/product\\_evaluation/grass-seed-supplier.pdf](https://ftp.dot.state.tx.us/pub/txdot-info/mnt/erosion/product_evaluation/grass-seed-supplier.pdf)

- Texas Department of Transportation. 2018a. *Roadside Vegetation Management Manual*. TxDOT Maintenance Division, Austin, Texas. Accessed at: <http://onlinemanuals.txdot.gov/txdotmanuals/veg/veg.pdf>
- Texas Department of Transportation. 2018b. *TxDOT Monarch Activities*. TxDOT Maintenance Division, Austin, Texas. Accessed at: <https://static.tti.tamu.edu/conferences/envr18/presentations/general/markwardt.pdf>
- Texas Department of Transportation. 2018c. *Roadway Design Manual*. Accessed at: <http://onlinemanuals.txdot.gov/txdotmanuals/rdw/rdw.pdf>
- Texas Department of Transportation. 2019. *Wildflower Program*. Accessed at: <https://www.txdot.gov/inside-txdot/division/maintenance/wildflower-program.html>
- Texas Department of Transportation. 2020a. *Grass, Weed and Wildflower Guide: Quick Reference; Grasses, Weeds and Wildflowers Found Throughout Texas*. Accessed at: <http://ftp.dot.state.tx.us/pub/txdot-info/mnt/grass-wildflower-weed-guide.pdf>
- Texas Department of Transportation. 2020b. *Wildflower Program: Regional Seed List*. Accessed at: <https://www.txdot.gov/inside-txdot/division/maintenance/wildflower-program/regional-list.html>
- Texas Department of Transportation. 2021. *Standard Highway Sign Designs for Texas*. 2012 Edition, Revision 4, May 2021. Accessed at: <http://ftp.dot.state.tx.us/pub/txdot-info/trf/shsd/2012/complete.pdf>
- Texas Monarch Watch. 2004. *Midpoint peak Migration Dates per Monarch Watch*. Accessed at: <http://texasento.net/dplex.htm>
- Texas State Soil and Water Conservation Board. 2016. *Enhancing and restoring monarch butterfly habitat in Texas*. TSSWCB Monarch Habitat Project Flyer. Accessed at: <https://www.tsswcb.texas.gov/sites/default/files/files/programs/Conservation%20initiatives/TSSWCB%20Monarch%20Flyer.pdf>
- Tracy J.L., and Coulson R.N. 2019. *Eastern Monarch Butterfly Fall Migratory Roadkill Distribution and Hotspot Regions within the Coastal and Central Migratory Funnels of Texas*. Texas A&M Department of Entomology/Texas Transportation Institute Project Final Report. TxDOT Environmental Affairs Division, Austin, Texas. 32 pp. Accessed at: [https://www.dropbox.com/s/an9wuzkyr54xdb0/TTI\\_TAMU%20Texas%20Monarch%20Roadkill%20Fall%202018%20Report.docx?dl=0](https://www.dropbox.com/s/an9wuzkyr54xdb0/TTI_TAMU%20Texas%20Monarch%20Roadkill%20Fall%202018%20Report.docx?dl=0)
- Tracy J.L., Kantola T., Baum K.A., and Coulson R.N. 2019. Modeling fall migration pathways and spatially identifying potential migratory hazards for the eastern monarch butterfly. *Landscape Ecology*, 34: 443-458.

- Tracy J.L., Kantola T., Baum K.A., Coulson, R.N. 2022. Distribution and phenology of monarch butterfly larvae and their milkweed hosts in the South Central US. *Biodiversity and Conservation*, In review. <https://www.researchsquare.com/article/rs-755161/v2>
- University of Minnesota Center for Transportation Studies. 2017. New recommendations aim to help turfgrass thrive on Minnesota roadsides. *Catalyst*, September 2017. Accessed at: <http://www.cts.umn.edu/publications/catalyst/2017/september/turfgrass>
- U.S. Department of Agriculture Natural Resources Conservation Service. 2015a. *Monarch Butterfly Habitat Development Project*. USDA-NRCS, Washington, D.C. Accessed at: [https://www.nrcs.usda.gov/wps/PA\\_NRCSConsumption/download?cid=nrcseprd414244&ext=pdf](https://www.nrcs.usda.gov/wps/PA_NRCSConsumption/download?cid=nrcseprd414244&ext=pdf)
- U.S. Department of Agriculture Natural Resources Conservation Service. 2015b. *Monarch Butterflies Plant Lists: Southern Plains; Kansas, Oklahoma, and Texas*, 4 pp. Accessed at: [https://www.nrcs.usda.gov/wps/PA\\_NRCSConsumption/download?cid=nrcseprd391624&ext=pdf](https://www.nrcs.usda.gov/wps/PA_NRCSConsumption/download?cid=nrcseprd391624&ext=pdf)
- US Department of Agriculture NRCS. 2018. *Important Plants of the Monarch Butterfly, Southern Great Plains: Staff Guide*. Monarch butterflies plant lists: Southern plains; Kansas, Oklahoma, and Texas. 100 pp Available at: [https://www.nrcs.usda.gov/wps/PA\\_NRCSConsumption/download?cid=nrcseprd772806&ext=pdf](https://www.nrcs.usda.gov/wps/PA_NRCSConsumption/download?cid=nrcseprd772806&ext=pdf)
- U.S. Department of Agriculture Natural Resources Conservation Service. 2020. *Plant Materials Centers*. USDA NRCS Plant Materials Program. Accessed at: <https://www.nrcs.usda.gov/wps/portal/nrcs/main/plantmaterials/pmc/>
- U.S. Department of Agriculture Natural Resources Conservation Service. 2020. *Milkweed Plug Planting Instructions*. USDA NRCS Plant Jamie L. Whitten Plant Materials Center, Coffeerville, Mississippi. Accessed at: [https://www.nrcs.usda.gov/Internet/FSE\\_PLANTMATERIALS/publications/mspmctn12700.pdf](https://www.nrcs.usda.gov/Internet/FSE_PLANTMATERIALS/publications/mspmctn12700.pdf)
- U.S. Department of Agriculture Natural Resource Conservation Service and US Department of Interior Fish and Wildlife Service. 2016. *Monarch Butterfly Conference Report*. Accessed at: [https://webcache.googleusercontent.com/search?q=cache:Rdrb\\_jogrMEJ:https://www.nrcs.usda.gov/wps/PA\\_NRCSConsumption/download%3Fcid%3Dnrcseprd894208%26ext%3Dpdf+%&cd=4&hl=en&ct=clnk&gl=us](https://webcache.googleusercontent.com/search?q=cache:Rdrb_jogrMEJ:https://www.nrcs.usda.gov/wps/PA_NRCSConsumption/download%3Fcid%3Dnrcseprd894208%26ext%3Dpdf+%&cd=4&hl=en&ct=clnk&gl=us)

- U.S. Department of Agriculture and U.S. Department of Interior. 2015. *Pollinator-Friendly Best Management Practices for Federal Lands*. Washington, D.C. Accessed at: <https://www.fs.fed.us/wildflowers/pollinators/BMPs/documents/PollinatorFriendlyBMPsFederalLands05152015.pdf>
- U.S. Department of Interior Fish and Wildlife Service. 2005. *Habitat Conservation Plans: Section 10 of the Endangered Species Act*. USDI-FWS Endangered Species Program, Arlington, Virginia. Accessed at: <http://www.fws.gov/endangered/hcp/>
- U.S. Department of Interior Fish and Wildlife Service. 2012. *Conservation Banking: Incentives for Stewardship*. USDI-FWS Endangered Species Program, Arlington, Virginia. Accessed at: <http://www.fws.gov/endangered/>
- U.S. Department of Interior Fish and Wildlife Service. 2014. Endangered and threatened wildlife and plants; 90-day findings on two petitions [California Gnatcatcher and monarch butterfly]. *Federal Register*, 79(50): 78775-78778. Accessed at: <https://www.govinfo.gov/content/pkg/FR-2014-12-31/pdf/2014-30574.pdf>
- U.S. Department of Interior Fish and Wildlife Service. 2016. *Archived Highlight Stories*. USDI FWS Pacific Region. Accessed at: [https://www.fws.gov/pacific/highlights\\_archive/Feature.cfm?id=14270](https://www.fws.gov/pacific/highlights_archive/Feature.cfm?id=14270)
- U.S. Department of Interior Fish and Wildlife Service. 2017a. Endangered and threatened wildlife and plants; Endangered species status for rusty patched bumble bee. *Federal Register*, 82(7): 3186-3208. Accessed at: <https://www.govinfo.gov/content/pkg/FR-2017-01-11/pdf/2017-00195.pdf>
- U.S. Department of Interior Fish and Wildlife Service. 2017b. *Service Partners with the National Fish and Wildlife Foundation through the Monarch Butterfly Conservation Fund*. Accessed at: <https://www.fws.gov/midwest/news/MonarchGrants.html>
- U.S. Department of Interior Fish and Wildlife Service. 2019a. International partners continue to work to conserve monarch butterflies as deadline for decision on protected status is extended. *Fish and Wildlife Service News Release*, 24 May, 2019. Accessed at: [https://www.fws.gov/savethemonarch/news\\_release24May2019.html](https://www.fws.gov/savethemonarch/news_release24May2019.html)
- U.S. Department of Interior Fish and Wildlife Service. 2019b. *Section 7 Consultation: A Brief Overview*. Accessed at: <https://www.fws.gov/midwest/endangered/section7/section7.html>
- U.S. Department of Interior Fish and Wildlife Service. 2020a. *Biological Opinion and Conference Opinion on the U.S. Fish and Wildlife Service's approval of a Candidate Conservation Agreement with Assurances and Candidate Conservation Agreement and its issuance of an associated Endangered Species Act Section 10(a)(1)(A) Permit (TAILS No. 03E00000-2020-F-0001)*. Letter of 3 April, 2020. Accessed at:

<https://www.fws.gov/savethemonarch/pdfs/Monarch%20CCAA%20Biological%20Opinion%20Final%20-%204-3-20.pdf>

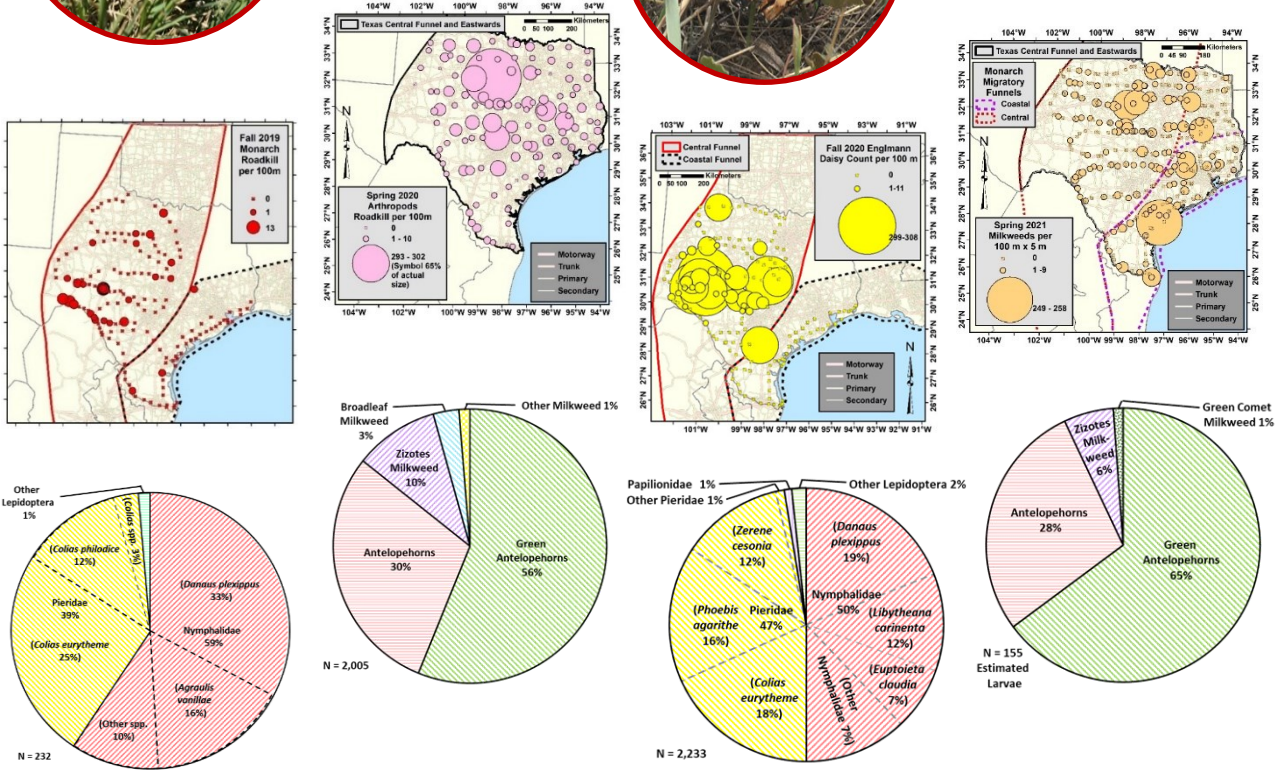
- US Department of Interior Fish and Wildlife Service. 2020b. U.S. Fish and Wildlife Service finds Endangered Species Act listing for monarch butterfly warranted but precluded. 15 December, 2020, press release. Accessed at: 2020<https://www.fws.gov/news/ShowNews.cfm?ref=u.s.-fish-and-wildlife-service-finds-endangered-species-act-listing-for-&ID=36817>.
- U.S. Department of Interior Fish and Wildlife Service. 2022. Endangered and threatened wildlife and plants; Endangered species for prostrate milkweed and designation of critical habitat [*Asclepias prostrata*]. *Federal Register*, 87(31): 8509-8543. Accessed at: <https://www.govinfo.gov/link/fr/87/8509>
- U.S. Department of Interior National Park Service. 2015. *Big Bend National Park Facebook Page*, 14 October 2015. Accessed at: <https://www.facebook.com/BigBendNPS/photos/a.871714252846895.1073741827.146679585350369/1072682929416692/>
- U.S. Department of Transportation Federal Highway Administration. 2002. *Life-Cycle Cost Analysis Primer*. Washington, D.C. Accessed at: <https://www.fhwa.dot.gov/asset/lcca/010621.pdf>
- U.S. Department of Transportation Federal Highway Administration. 2015. *Roadside Best Management Practices that Benefit Pollinators: Handbook for Supporting Pollinators through Roadside Maintenance and Landscape Design*. Washington, D.C. Accessed at: [http://www.xerces.org/wp-content/uploads/2016/08/BMPs\\_pollinators\\_landscapes.pdf](http://www.xerces.org/wp-content/uploads/2016/08/BMPs_pollinators_landscapes.pdf)
- U.S. Department of Transportation Federal Highway Administration. 2016. *Pollinators and Roadsides: Best Management Practices for Managers and Decision Makers*. Washington, D.C. Accessed at: [http://www.xerces.org/wp-content/uploads/2016/07/BMPs\\_pollinators\\_roadsides.pdf](http://www.xerces.org/wp-content/uploads/2016/07/BMPs_pollinators_roadsides.pdf)
- U.S. Department of Transportation Federal Highway Administration. 2017. *Traffic Calming ePrimer*. Washington, D.C. Accessed at: [https://safety.fhwa.dot.gov/speedmgt/traffic\\_calm.cfm](https://safety.fhwa.dot.gov/speedmgt/traffic_calm.cfm)
- U.S. Department of Transportation Federal Highway Administration. 2019. Lesson 11: Traffic calming. In: *FHWA Course on Bicycle and Pedestrian Transportation*. Washington, D.C. Accessed at: [https://safety.fhwa.dot.gov/ped\\_bike/univcourse/swless11.cfm](https://safety.fhwa.dot.gov/ped_bike/univcourse/swless11.cfm)
- U.S. Department of Transportation Federal Highway Administration and Central Federal Lands Highway Division. 2011. *Wildlife Crossing Structure Handbook: Design and*



- Evaluation in North America*. Publication No. FHWA-CFL/TD-11-003, Federal Highway Administration, Washington, DC. Accessed at: [https://www.environment.fhwa.dot.gov/env\\_topics/ecosystems/Pollinators\\_Roadsides/BMPs\\_pollinators\\_landscapes\\_hi-rez.pdf](https://www.environment.fhwa.dot.gov/env_topics/ecosystems/Pollinators_Roadsides/BMPs_pollinators_landscapes_hi-rez.pdf)
- Valtonen, A. and Saarinen, K. 2005. A highway intersection as an alternative habitat for a meadow butterfly: effect of mowing, habitat geometry and roads on the ringlet (*Aphantopus hyperantus*). *Annales Zoologici Fennici*, 42: 545-556.
- van der Ree, R., Smith, D.J., and Grilo, C. 2015. *Handbook of Road Ecology*. John Willey & Sons Ltd., West Sussex, United Kingdom.
- van Langevelde, F. and Jaarsma, C.F. 2009. Modeling the effect of traffic calming on local animal population persistence. *Ecology and Society*, 14(2): 39.
- van Langevelde, F., van Dooremalen, C., and Jaarsma, C.F. 2009. Traffic mortality and the role of minor roads. *Journal of Environmental Management*, 90(1): 660-667.
- van Wieren, S.E. and Worm, P.B. 2001. The use of a motorway wildlife overpass by large mammals. *Netherlands Journal of Zoology*, 51(1): 97-105.
- Vidal, O., and Rendón-Salinas, E. 2014. Dynamics and trends of overwintering colonies of the monarch butterfly in Mexico. *Biological Conservation* 180: 165–175.
- Washington State Department of Transportation. 2019. *Construction on I-90 Snoqualmie Pass East Project*. Washington State Department of Transportation, Olympia, Washington. Accessed at: <https://www.flickr.com/photos/wsdot/sets/72157627008507786/with/36834206590/>
- Weller, C. 2015. Construction of roads and wildlife mitigation measures: pitfalls and opportunities. In: van der Ree, R., Smith, D.J., and Grilo, C., (eds.), *Handbook of Road Ecology*. John Willey & Sons Ltd., West Sussex, United Kingdom, pp.60-64.
- Wepprich, T., Adrion, J.R., Ries, L., Wiedmann, J., and Haddad, N.M. 2019. Butterfly abundance declines over 20 years of systematic monitoring in Ohio, USA. *PLoS ONE*, 14(7): e0216270. <https://journals.plos.org/plosone/article/file?id=10.1371/journal.pone.0216270&type=printable>
- WildlifeandRoads.org. 2007. *Wildlife and Roads: A Resource for Mitigating the Effects of Roads on Wildlife Using Wildlife Crossings Such as Overpasses, Underpasses, and Crosswalks*. Transportation Research Board, Washington, D.C. Accessed at: <http://www.wildlifeandroads.org/>

- Wilkins, D.C., Kockelman, K.M. and Jiang, N. 2019. Animal-vehicle collisions in Texas: how to protect travelers and animals on roadways. *Accident Analysis & Prevention*, 131: 157-170.
- Wolin, C.L., Galen, C., and Watkins, L. 1984. The breeding system and aspects of pollination effectiveness in *Oenothera speciosa* (Onagraceae). *The Southwestern Naturalist*, 29(1): 15-20.
- WSP.com. 2019. Utah opens state's first wildlife bridge overpass. *WSP Insights*, January 2019. Accessed at: <https://www.wsp.com/en-US/insights/utah-opens-states-first-wildlife-bridge-overpass>
- Wyoming Department of Transportation. 2019. *Baggs Underpass*. Wyoming DOT, Cheyenne, Wyoming. Accessed at: [http://www.dot.state.wy.us/home/engineering\\_technical\\_programs/environmental\\_services/wildlife-1.html](http://www.dot.state.wy.us/home/engineering_technical_programs/environmental_services/wildlife-1.html)
- Zocalo.com.mx. 2016. *They Ignore the Passage of the Monarchs*. (In Spanish). Accessed at: [https://www.zocalo.com.mx/new\\_site/articulo/ignoran-paso-de-la-mariposa-monarca](https://www.zocalo.com.mx/new_site/articulo/ignoran-paso-de-la-mariposa-monarca)
- ZunZun.com. 2019. *ZunZunSite3 Online Curve Fitting and Surface Fitting Website*. Accessed at: <http://zunzun.com>

# PART II: TEXAS MONARCH AND ARTHROPOD ROADKILL AND ROADSIDE MILKWEED AND OTHER NECTAR PLANTS



## PREFACE TO PART II

Part II presents results from 2019-2021 Texas spring and fall field observations on arthropod roadkill and densities of roadside milkweeds and other monarch-preferred nectar plants. Chapter 1 provides a general introduction on arthropod roadkill. Chapters 2-5 present methods, results, and discussion for each set of seasonal observations: fall 2019 (Chapter 2), spring 2020 (Chapter 3), fall 2020 (Chapter 4), and spring 2021 (Chapter 5). Methods were mostly similar among years and seasons but include differences that are discussed and illustrated with figures and tables. Results include yearly localities of seasonal hotspots for roadkill of monarchs and other arthropods, and regional percentages and total estimated roadkill for various arthropod taxa across different seasons and years.

## EXECUTIVE SUMMARY

Transect counts of arthropod roadkill and roadside nectar plants were made throughout most of Texas for Fall 2019, Spring 2020, Fall 2020, and Spring 2021. Lepidoptera generally dominated Texas fall and spring arthropod roadkill, except in the spring of 2020 when Hymenoptera and Coleoptera dominated. Roadkill of pierid butterflies, such as the orange sulphur, exceeded that of monarchs in the fall of 2020. Monarchs were generally a minor component of butterfly roadkill in the spring of 2020 and 2021, when orange sulphur roadkill dominated. The most consistent perennial fall monarch roadkill hotspot zones were along IH-10 between Sonora and Sheffield (San Angelo District) and Sanderson Canyon along US-90 (Odessa District) in the Central Funnel, and the Lavaca Bay (Yoakum District), Lyndon B Johnson and John F Kennedy (Corpus Christi District) causeways in the Coastal Funnel. These perennial hotspot zones should be the focus of any trials of direct mitigation to reduce monarch roadkill.

Texas spring roadside milkweeds, which are critical as very high-value monarch nectar resources and primary larval host plants, were dominated by green antelopehorn, antelopehorns, and zizotes milkweeds, with broadleaf milkweed locally common in West Texas. Spring 2021 roadside milkweed densities averaged about 87 per hectare, with milkweeds occurring in 40% of random dispersed transects. Dominant spring high value non-milkweed monarch preferred nectar plants included widely distributed Texas vervain and lemon beebalm, and regional stands of Engelmann daisy and lance leaved coreopsis. Milkweeds and golden crownbeard were the only common very high value monarch spring roadside nectar plants. Monarch preferred spring 2021 nectar plants occurred in about 83 and 87% of the dispersed and random dispersed transects, respectively, with densities averaging around 1,990 and 2,201 nectar plants per hectare. Common fall 2020 roadside monarch preferred nectar plants were Engelmann daisy, Spanish gold, green antelopehorn, heath aster, antelopehorns, and zexmenia in the Central Funnel, and camphor daisy, seaside goldenrod, climbing milkweed vine, and Texas vervain in the Coastal Funnel. A weak but significant correlation was found between monarch roadkill and counts of milkweed plants in the fall of 2020 and spring of 2021 (but not spring of 2020). This correlation may not be causal, and it could have resulted from monarchs migrating through areas with higher milkweed and nectar plant populations in general.

Four percent of dispersed roadside transects in Texas had monarch larvae in spring 2021, with an average density of 0.02 to 0.06 larvae per plant for the three common milkweed species. A significant but weak correlation was found between roadside monarch larvae per hectare and number of milkweed plants per hectare in both the spring of 2021 and 2020.



## CHAPTER 1. INTRODUCTION

Road mortality can have a significant impact on insect populations (Munoz et al. 2015, Martin et al. 2018), and it probably contributes to their global decline (Samways 2019). Particularly at risk are pollinators (Baxter-Gilbert et al. 2015) and Lepidoptera, comprising at least 25% of roadkill arthropod taxa (Seibert and Conover 1991, Rao and Girish 2007, Yamada et al. 2010, Baxter-Gilbert et al. 2015). Monarch butterflies, *Danaus plexippus* (Nymphalidae: Danainae), are especially susceptible to roadkill during fall migration as their travel pathway narrows into a funnel through Texas and into Mexico (Kantola et al. 2019, Mora Alvarez et al. 2019). Several species of related danaine butterflies in the genera *Euploea* and *Tirumala*, are well known as migrants in southern India (Kunte 2005, Patil et al. 2014, Patil 2016, Santhos and Basavarajappa 2017, Bhaumik and Kunte 2017) and Taiwan (Wang and Emmel 1990), where they are also reported as especially susceptible to migratory roadkill. Asian migratory danaines noted for high roadkill include dark blue tiger (*Tirumala septentrionis*), common crow (*Euploea core*), and double-branded crow (*E. sylvester*) in southern India (Santhosh and Basavarajappa 2014), and several species of purple crow butterflies (*Euploea* spp.) in Taiwan (Her 2008, Taiwan Environmental Protection Administration 2010, Taiwan Area National Freeway Bureau. 2015). Migratory danaine butterflies can comprise 35-96% of seasonal Lepidoptera roadkill in southern India (Roshnath and Cyriac 2013, Sony and Arun 2015, Sathish-Narayanan et al. 2016). In relation to other species of Lepidoptera, monarch roadkill has been only 3% in Florida (Halbriter et al. 2015) and 5% in Illinois (McKenna et al. 2001). The proportion of monarch road mortality in Texas among other arthropod taxa is most likely greater during the fall migration, but it has not been previously studied.

Much higher monarch road mortality was found in the fall for 2016-2019 (Kantola et al. 2019, Tracy and Coulson 2019) compared to the spring 2017 (Kantola et al. 2019). Spring road mortality for monarchs may be higher in some years, and both the total and proportional roadkill may differ significantly for other arthropod taxa between spring and fall. The spring roadside distribution of milkweeds and monarch-preferred nectar plants is important to understand for prioritizing locations for conservation and restoration of monarch roadside habitats as compensatory mitigation for monarch road mortality.

We recorded arthropod roadkill, and roadside milkweeds, monarch-preferred nectar plants, and monarch larvae across most of Texas for Fall 2019 (Chapter 3), Spring 2020 (Chapter 4), Fall 2020 (Chapter 5), and Spring 2021 (Chapter 6). We compare Texas monarch roadkill rates and arthropod roadkill composition among seasons and years and to 20 other roadkill studies across North America, Europe, and Asia. Roadkill hotspots are identified, and novel comparisons are made of the spatial distribution as

well as correlation of roadkill for different arthropod taxa. Data from fall 2020 roadkill was used to further examine yearly variability in monarch roadkill and its association with drainages and causeways. We standardized simple extrapolation methods for estimating fall monarch roadkill in Texas to facilitate direct comparison of roadkill data among different years and seasons. The general distributions of Texas spring roadside milkweeds and nectar plants are also analyzed for the first time. Random dispersed transects were added starting in fall 2020 in order to more objectively estimate roadside milkweed densities. Monarch-preferred nectar plant count transects in fall 2020 were also added away from the roadway (5-10 m from road edge) for comparison with plants along the road edge (0-5m from road edge) to better understand variability pollinator resources along a wider section of the right of way.

## References

- Alabama Butterfly Atlas. 2020. *Explore Alabama's Butterflies* [species search]. Accessed at: <https://alabama.butterflyatlas.usf.edu/>
- Arbogast, R.T. 1966. Migration of *Agraulis vanillae* (Lepidoptera, Nymphalidae) in Florida. *The Florida Entomologist*, 49(3): 141-145.
- Baker, R.R. 1969. The evolution of the migratory habit in butterflies. *The Journal of Animal Ecology*, 38(3): 703-746.
- Baxter-Gilbert, J.H., Riley, J.L., Neufeld, C.J., Litzgus, J.D., and Lesbarrères, D. 2015. Road mortality potentially responsible for billions of pollinating insect deaths annually. *Journal of Insect Conservation*, 19(5): 1029–1035.
- Bharos, A.M.K. 2000. Large scale emergence and migration of the Common Emigrant butterflies *Catopsilia pomona* (Family: Pieridae). *Journal of the Bombay Natural History Society*, 97(2): 301.
- Bhaumik, V. and Kunte, K. 2018. Female butterflies modulate investment in reproduction and flight in response to monsoon-driven migrations. *Oikos*, 127(2): 285-296.
- Blumenthal, R. 2006. In Texas, conditions lead to a rabble of butterflies. *New York Times* 27 July, 2006. Accessed at: <https://www.nytimes.com/2006/07/27/us/27butterflies.html>
- Dykman, S. 2019. Once a butterbiker, always a butterbiker. *Beyond a Book* blog, 8 December, 2019. Accessed at: <http://www.beyondabook.org/butterbike-blog-1/2019/12/6/once-a-butterbiker-always-a-butterbiker>
- Einem, G.E. 2003. Fall migration of queens, *Danaus gilippus strigosus* Bates, in Mexico and Texas. *News of the Lepidopterist's Society*, 45(2): 39, 47. Accessed at:

<http://citeseerx.ist.psu.edu/viewdoc/download?doi=10.1.1.695.410&rep=rep1&type=pdf>

- Fisher, K.J. 1945, December. Two species of *Colias* migrating in central USA (Lep. Rhopalocera). *Proceedings of the Royal Entomological Society of London. Series A, General Entomology*, 20(10-12): 107-109.
- Gaudel, P., Paudel, M., Gaudel, P., Giri, B.R. and Shrestha, B.R. 2020. Mortality census of the road-killed butterflies in Mahendra highway, Nepal. *Journal of Insect Biodiversity and Systematics*, 6(1): 87-99.
- Gilbert, L.E. 1985. Ecological factors which influence migratory behavior in two butterflies of the semi-arid shrublands of south Texas. In: Rankin, M.A.R. (ed.), *Contributions in Marine Science: Migration: Mechanisms and Adaptive Significance*, University of Texas Marine Science Institute, Port Aransas, Texas, Supplemental Vol. 27: 724-747. Accessed at: <http://www.texasento.net/Gilbert1985.pdf>
- Glassberg, J. 1999. *Butterflies through Binoculars: The East*. Oxford University Press, New York, New York. Accessed at: [https://www.google.com/books/edition/\\_/vxJexOBOj5QC?hl=en&gbpv=1&bsq=Queen](https://www.google.com/books/edition/_/vxJexOBOj5QC?hl=en&gbpv=1&bsq=Queen)
- Halbritter, D.A., Daniels, J.C., Whitaker, D.C. and Huang, L. 2015. Reducing mowing frequency increases floral resource and butterfly (Lepidoptera: Hesperioidea and Papilionoidea) abundance in managed roadside margins. *Florida Entomologist*, 98(4):1081-1092.
- Her, K. 2008. Ensuring a Safe Journey. *Taiwan Today, Taiwan Review*, 1 August, 2008. Accessed at: <http://taiwantoday.tw/news.php?post=23836&unit=14,29,34,45>
- iNaturalist. 2020a. *Observations*. Accessed at: <https://www.inaturalist.org/observations/>  
Observation numbers to append to URL: monarch – 21358663, gulf fritillary- 49150, goatweed butterfly - 5666603, queen – 1644480, elada checkerspot – 195679, red admiral – 197336, question mark – 197328, orange Sulphur – 722604, clouded Sulphur – 32776145, large white – 39201480, cabbage white – 26344682, green-veined white - 33975261, small tortoiseshell - 368645
- iNaturalist. 2020b. *Observations- Roadkills of Texas - American Snout*. Accessed at: [https://www.inaturalist.org/observations?captive=any&place\\_id=any&project\\_id=17477&verifiable=any&view=&taxon\\_id=58561&page=](https://www.inaturalist.org/observations?captive=any&place_id=any&project_id=17477&verifiable=any&view=&taxon_id=58561&page=)
- iNaturalist. 2020c. *Observations – Roadkills of Texas – Common Buckeye*. Accessed at: [https://www.inaturalist.org/observations?captive=any&place\\_id=any&project\\_id=17477&verifiable=any&view=&iconic\\_taxa=Insecta&taxon\\_id=48505&page=](https://www.inaturalist.org/observations?captive=any&place_id=any&project_id=17477&verifiable=any&view=&iconic_taxa=Insecta&taxon_id=48505&page=)

- iNaturalist. 2020d. *Observations – Roadkills of Texas – Insects*. Accessed at: [https://www.inaturalist.org/observations?captive=any&place\\_id=any&project\\_id=17477&verifiable=any&view=species&iconic\\_taxa=Insecta](https://www.inaturalist.org/observations?captive=any&place_id=any&project_id=17477&verifiable=any&view=species&iconic_taxa=Insecta)
- iNaturalist. 2020e. *Observations*. Accessed at: <https://www.inaturalist.org/observations/>  
Observation numbers to append to URL: lemon emigrant – 29552610, wandering glider – 20248118 (credit Lenny Worthington), double-branded crow- 29454384, dark blue tiger – 34627470, lime swallowtail – 27876700, common crow – 30749150, blue tiger – 28989296
- Jeganathan, P., Mudappa, D., Kumar, A. and Raman, T.S. 2018. Seasonal variation in wildlife roadkills in plantations and tropical rainforest in the Anamalai Hills, Western Ghats, India. *Current Science*, 114: 619-626.
- Kantola, T., Tracy, J.L., Baum, K.A., Quinn, M.A. and Coulson, R.N. 2019. Spatial risk assessment of eastern monarch butterfly road mortality during autumn migration within the southern corridor. *Biological Conservation*, 231:150-160.
- Karve, P. 2008. Butterfly roadkills: Nannaj Wildlife Sanctuary, Solapur, Maharashtra. *My Butterflying* blog, 10 April, 2008. Accessed at: <http://karvepinakin.blogspot.com/2008/04/butterfly-road-kills.html>
- Keilsohn, W., Narango, D.L. and Tallamy, D.W. 2018. Roadside habitat impacts insect traffic mortality. *Journal of Insect Conservation*, 22(2): 183-188.
- Kunte, K. 2005. Species composition, sex-ratios and movement patterns in Danaine butterfly migration s in southern India I. *Journal of the Bombay Natural History Society*, 102(3): 280-286. Accessed at: <http://biodiversitylab.ncbs.res.in/sites/default/files/images/website/KunteDanaineMigration05.pdf>
- Kunte, K., Sondhi, S., and Roy, P. 2020. *Butterflies of India*, v. 2.76. Indian Foundation for Butterflies. [*Eurema hecabe* and *Catopsilia pyranthe*]. Accessed at: <https://www.ifoundbutterflies.org>
- Martin, A.E., Graham, S.L., Henry, M., Pervin, E. and Fahrig, L. 2018. Flying insect abundance declines with increasing road traffic. *Insect Conservation and Diversity*, 11(6): 608-613.
- McKenna, D.D., McKenna, K.M., Malcom, S.B., and Berenbaum, M.R. 2001. Mortality of Lepidoptera along roadways in central Illinois. *Journal of Lepidopterists' Society*, 55 (2): 63-68.
- Monarch Watch. 2020. Monarch Population Status. *Monarch Watch Blog*, 13 March 2020. Accessed at: <https://monarchwatch.org/blog/2020/03/13/monarch-population-status-42/>

- Mora Alvarez, B.X., Carrera-Treviño, R., and Hobson, K.A. 2019. Mortality of monarch butterflies (*Danaus plexippus*) at two highway crossing "hotspots" during autumn migration in Northeast Mexico. *Frontiers in Ecology and Evolution*, 7: 273.
- Munguira, M.L. and Thomas, J.A. 1992. Use of road verges by butterfly and burnet populations, and the effect of roads on adult dispersal and mortality. *Journal of Applied Ecology*, 29(2): 316-329.
- Muñoz, P.T., Torres, F.P. and Megías, A.G. 2015. Effects of roads on insects: a review. *Biodiversity and Conservation*, 24(3): 659-682.
- Nielsen, J.E. 2015. A range extension for *Eurema alitha* (C. & R. Felder) (Lepidoptera: Pieridae) in Australia, with notes on the migratory behaviour of *Eurema* species in South-east Queensland. *Australian Entomologist*, 42(1): 15-18.
- Patil, M.D. 2016. Natural history observations on mass congregation and diapause behaviour of pre-migratory roosting Danainae (Lepidoptera: Nymphalidae) from Sahyadri Mountains, India. *South Asian Journal Life Sciences*, 4(1): 25-31.
- Patil, V.K., Patil, M.D. and Narkhede, S.S. 2014. Danainae congregation in the Konkan region of Maharashtra, India. *Current Science*, 106(4): 514-515.
- Ramesh, T., Hussain, K.J., Satpathy, K.K. and Selvanayagam, M. 2013. Seasonal population dynamics and migration of butterflies in coastal plains of Kalpakkam, southern India. In: Gupta, V.K. and Verma, A.K. (eds.) *Animal Diversity Natural History and Conservation*, Vol. 3, M/S Daya Publishing House, New Delhi, India, pp. 37-54.
- Rao, R.S.P. and Girish, M.S. 2007. Road kills: Assessing insect casualties using flagship taxon. *Current Science*, 92(6): 830-837.
- Roer, H. 1991. On the direction of migration and flight capacity of the nymphalids *Inachis io*, *Aglais urticae* and *Vanessa atalanta* in the central European area after recapturing marked butterflies. *Entomologische Berichten*, 51(12): 179-182.
- Roshnath, R. and Cyriac, V.P. 2013. Way Back Home-Butterfly Roadkills. *Zoo's Print*, 28(12): 18-20. Accessed at: <http://www.zoosprint.zooreach.org/index.php/zp/article/download/1339/1237>
- Samways, M.J. 2019. Addressing global insect meltdown. *The Ecological Citizen*, 3(Suppl A): 3-6.
- Santhosh, S., and Basavarajappa, S. 2014. Road mortality of migrant butterflies [Nymphalidae: Danaiane] at National Highway-209 in Chamarajanagar District of Karnataka, India. *Indian Journal of Applied Research*, 4: 553-557. Accessed at: [https://www.worldwidejournals.com/indian-journal-of-applied-research-\(IJAR\)/fileview.php?val=September\\_2014\\_1492849834\\_166.pdf](https://www.worldwidejournals.com/indian-journal-of-applied-research-(IJAR)/fileview.php?val=September_2014_1492849834_166.pdf)



- Santhosh, S. and Basavarajappa, S. 2017. Migratory behaviour of two butterfly species (Lepidoptera: Nymphalidae) amidst agriculture ecosystems of South-Western Karnataka, India. *Journal of Entomology and Zoological Studies*, 5(1): 758-765. Accessed at: [https://www.researchgate.net/profile/Basavarajappa\\_Sekarappa/publication/316826047\\_Migratory\\_behaviour\\_of\\_two\\_butterfly\\_species\\_Lepidoptera\\_Nymphalidae\\_amidst\\_agriculture\\_ecosystems\\_of\\_South-Western\\_Karnataka\\_India/links/5912bd674585152e1998a4c0/Migratory-behaviour-of-two-butterfly-species-Lepidoptera-Nymphalidae-amidst-agriculture-ecosystems-of-South-Western-Karnataka-India.pdf?origin=figuresDialog](https://www.researchgate.net/profile/Basavarajappa_Sekarappa/publication/316826047_Migratory_behaviour_of_two_butterfly_species_Lepidoptera_Nymphalidae_amidst_agriculture_ecosystems_of_South-Western_Karnataka_India/links/5912bd674585152e1998a4c0/Migratory-behaviour-of-two-butterfly-species-Lepidoptera-Nymphalidae-amidst-agriculture-ecosystems-of-South-Western-Karnataka-India.pdf?origin=figuresDialog)
- Saraf, K.K. and Jadesh, M. 2017. A preliminary study on road killed butterflies at National Highway-50, Kalaburagi district, Karnataka, India. *International Journal of Entomology Research*, 2(1): 42-50.
- Sathish-Narayanan, S., Pradeepa, V., Venkatesh, A. and Kanchana, R. 2016. Effect of road kills on wildlife populations in Kalakad Mundanthurai Tiger Reserve. *International Journal of Advanced Research*, 4(3): 193-204.
- Seibert, H.C. and Conover, J.H. 1991. Mortality of vertebrates and invertebrates on an Athens County, Ohio, Highway. *The Ohio Journal of Science*, 91(4): 163-166.
- Skórka, P. 2016. The detectability and persistence of road-killed butterflies: an experimental study. *Biological Conservation*, 200: 36-43.
- Skórka, P., Lenda, M., Moroń, D., Kalarus, K. and Tryjanowski, P. 2013. Factors affecting road mortality and the suitability of road verges for butterflies. *Biological Conservation*, 159: 148-157.
- Skórka, P., Lenda, M. and Moroń, D. 2018. Roads affect the spatial structure of butterfly communities in grassland patches. *PeerJ*, 6: e5413.
- Schweitzer, D.F. 2006. The winter ecology of *Colias eurytheme* Boisduval (Pieridae) and its dependence on exotic legumes in Southern New Jersey. *Journal of Lepidopterists' Society*, 60(1): 51-60.
- Sony, R.K. and Arun, P.R. 2015. A case study of butterfly road kills from Anaikatty Hills, Western Ghats, Tamil Nadu, India. *Journal of Threatened Taxa*, 7(14): 8154-8158. Accessed at: <https://www.zooreach.org/index.php/JoTT/article/download/1743/3468>
- Spieth, H.R. and Cordes, R. 2012. Geographic comparison of seasonal migration events of the large white butterfly, *Pieris brassicae*. *Ecological Entomology*, 37(6): 439-445.
- Taiwan Environmental Protection Administration. 2010. Environmental inspection: highways yield to flyways – EPA takes up butterfly conservation. *Environmental*

- Policy Monthly* (Environmental Protection Administration, Republic of China [Taiwan]). 13. pp. 9–10. Accessed at:  
<https://www.epa.gov.tw/cpDownloadCtl.asp?id=61993>
- Taiwan Area National Freeway Bureau. 2015. *National Road No. 3 Nanyun Interchange Project Butterfly Monitoring Survey Report*. (In Chinese). Accessed at:  
<https://www.freeway.gov.tw/UserFiles/File/Widening/HistoryArea/GroupAndCulture/2-5-1-2ButterflySurveyReport.pdf>
- Thogmartin, W.E., Diffendorfer, J.E., López-Hoffman, L., Oberhauser, K., Pleasants, J., Semmens, B.X., Semmens, D., Taylor, O.R. and Wiederholt, R. 2017. Density estimates of monarch butterflies overwintering in central Mexico. *PeerJ*, 5: e3221.
- Tracy, J.L., Kantola, T., Baum, K.A. and Coulson, R.N. 2019. Modeling fall migration pathways and spatially identifying potential migratory hazards for the eastern monarch butterfly. *Landscape Ecology*, 34(2): 443-458.
- Tracy J.L., and Coulson R.N. 2019. *Eastern Monarch Butterfly Fall Migratory Roadkill Distribution and Hotspot Regions within the Coastal and Central Migratory Funnels of Texas*. Texas A&M Department of Entomology/Texas Transportation Institute Project Final Report. TxDOT Environmental Affairs Division, Austin, Texas. 32 pp. Accessed at:  
[https://www.dropbox.com/s/an9wuzkyr54xdb0/TTI\\_TAMU%20Texas%20Monarch%20Roadkill%20Fall%202018%20Report.docx?dl=0](https://www.dropbox.com/s/an9wuzkyr54xdb0/TTI_TAMU%20Texas%20Monarch%20Roadkill%20Fall%202018%20Report.docx?dl=0)
- Troast, D., Suhling, F., Jinguji, H., Sahlén, G. and Ware, J. 2016. A global population genetic study of *Pantala flavescens*. *PloS one*, 11(3): e0148949.
- Vadivalagan, C., Gunasekaran, C. and Salahudeen, I. 2012. Molecular phylogeny of recurrent road killed butterflies in Nilgiri biosphere reserve, India, using CO1 gene marker. *African Journal Biotechnology*, 11(79): 14433-14439.
- Wang, H.Y. and Emmel, T.C. 1990. Migration and overwintering aggregations of nine danaine butterfly species in Taiwan (Nymphalidae). *Journal of Lepidopterists' Society*, 44: 216-228.
- Walker, T.J. 1978. Migration and re-migration of butterflies through north peninsular Florida: quantification with Malaise traps. *Journal of the Lepidopterists' Society*, 32(3): 178-190.
- Walker, T.J. 1991. Butterfly migration from and to peninsular Florida. *Ecological Entomology*, 16(2): 241-252.
- Walker, T.J. 2001. Butterfly migrations in Florida: seasonal patterns and long-term changes. *Environmental Entomology*, 30(6): 1052-1060.

- Wikelski, M., Moskowitz, D., Adelman, J.S., Cochran, J., Wilcove, D.S. and May, M.L. 2006. Simple rules guide dragonfly migration. *Biology Letters*, 2(3): 325-329.
- Williams, C.B. 1927. A study of butterfly migration in south India and Ceylon, based largely on records by Messrs. J. Evershed, EE Green, JCF Fryer and W. Ormiston. *Transactions of the Royal Entomological Society of London*, 75(1): 1-33.
- Williams, C.B. 1930. *The Migration of Butterflies*. Oliver & Boyd, London, United Kingdom.
- Williams, C.B., 1933. Further collected records relating to insect migration. *Transactions of the Royal Entomological Society of London*, 81(1): 103-116.
- Yamada, Y., Sasaki, H. and Harauchi, Y. 2010. Composition of road-killed insects on coastal roads around Lake Shikotsu in Hokkaido, Japan. *Journal Rakuno Gakuen University*, 34(2): 177-184.
- Yata, O. 1995. A revision of the Old World species of the genus *Eurema* Hübner (Lepidoptera, Pieridae): Part V. Description of the *hecabe* group (part). *Bulletin Kitakyushu Museum Natural History*, 14: 1-54.

## CHAPTER 2. FALL 2019 MONARCH AND ARTHROPOD ROADKILL

### Summary

Monarch roadkill in the migratory Central Funnel from Oklahoma to Mexico for fall 2019 was estimated at 0.74 million (1.24% of the Mexican overwintering population for 2019-20). Similarly, 0.81 million roadkill were estimated for 2017. Roadkill estimates in 2016 (2.82 million) and 2018 (5.96 million) were three to eight times higher than in the years of 2017 and 2019. Over the four-year period from 2016 to 2019, roadkill within the Texas portion of the Central Funnel ranged from 0.72% to 0.13% of the monarch overwintering populations, averaging 0.43%. Monarch roadkill in the migratory Coastal Funnel from Louisiana to Mexico for fall 2019 was estimated at 0.07 million (9% of the Central Funnel). The previous year, roadkill was estimated at 0.41 million (7% of that in the Central Funnel). Monarch roadkill in hotspot zones in the Texas portions of the Central and Coastal funnels ranged from 0-5% of the total estimated roadkill from 2016-2019. Consequently, direct roadkill mitigation focused on reducing roadkill in hotspots may be less effective than compensatory mitigation that focuses on increasing the spring monarch population and migratory success through promoting roadside spring larval host milkweeds and adult nectar plants. For all arthropod species in 2019, roadkill in the Central and Coastal funnels was estimated at about 3 million and 0.4 million, respectively. Lepidoptera comprised 70% and 86% of the arthropod roadkill in the Central and Coastal funnels, respectively. Previous roadkill studies report much lower roadkill proportions for Lepidoptera in North America, Europe, and Asia. The percent composition of monarchs among all Lepidoptera roadkill observed in this study was about 33% and 19% in the Central and Coastal funnels, respectively, which is much higher than other studies in North America. Monarchs and other fall migratory species, including gulf fritillaries, sulphurs and queens, make up the majority of the Lepidoptera roadkill in Texas. The spatial distribution of roadkill was significantly correlated among several butterfly taxa and species, particularly in the Central Funnel. Migratory butterflies also comprise a large portion of Lepidoptera roadkill in several other arthropod roadkill studies in North America, Europe, and Asia, particularly in those studies focusing on the spring or fall migratory periods. Further study is needed to determine how compensatory mitigation to promote seasonal availability of larval host plant and adult nectar resources for monarchs and other migratory butterflies may help offset negative impacts of road mortality during migration.

### Methods

Roadkill observations by a two person team were made following the same protocol as Kantola et al. (2019), employing 100 x 1 meter transects spaced about every 20-30 km. Roadkill transects were counted for three major Federal Highway Administration (FHWA)

road classes throughout the Texas portions of the monarch migratory Central and Coastal funnels of Tracy et al. (2019) (Fig. 1). Each roadkill transect was associated with an overlapping 100 x 5 meter monarch/milkweed/nectar plant transect and a 5 x 50 m plant percent cover transect (Fig. 2A). Fall Central Funnel field observations were generally made every other week from early to mid-October to late November. Fall Coastal Funnel field observations were made every other week from late November to mid-December. Spring roadkill surveys were made from the Central Funnel and eastwards in Texas from April to May. Field assistants worked in pairs and wore class III safety vests, hard hats with reflective tape, and steel toed boots (Fig. 2B) for recording roadkill (Fig. 2C).

Fall monarch and arthropod roadkill incidence in Texas from 100 m roadside transect data from 2016, 2017 (Kantola et al. 2019) and 2018 (Tracy and Coulson 2019) were combined with 2019 data from this study to determine relationships between arthropod counts on both sides of the roadway. These relationships were used to develop extrapolations when only one side of the roadway was counted, similar to procedures used by Kantola et al. (2019) (see Appendix and Table A.1). Roadkill estimates were further extrapolated across the Central and Coastal funnels, including their respective Texas portions, by multiplying roadkill rates per km with lengths of roadway within the various areas (e.g., McKenna et al. 2001, Kantola et al. 2019). Roadkill rate estimate methods were standardized and applied to previous 2016–2018 data for direct comparison with 2019 data. Additional fall 2019 roadkill transects were counted in areas with 10 or more monarch roadkill on both sides of the roadway in order to determine the length and roadkill rates over hotspot zones. These extra transects were omitted from the general transect dataset that was thinned to maintain a 10 km minimum distance between transects. The 10km thinned data was used for comparing roadkill rates per 100 m across various taxa and regions. Pairwise correlations of roadkill per 100 m by location were tested among selected arthropod taxa using the Spearman rank order correlation ( $r_s$ ), with Holm's correction for multiple comparisons with the *r psych* package

## Results

Estimated arthropod roadkill per transect, extrapolated to account for both sides of the roadway (see Appendix), was not significantly different among the three FHWA road classifications examined in this study (Table 1). Consequently, total lengths of the highway were pooled across classifications for the monarch migratory funnels for estimating total roadkill. Over all highway classifications, arthropod roadkill was about 2.93 per 100 m in the Central Funnel, which was significantly greater than the 0.79 roadkill per 100 m observed in the Coastal Funnel (Table 2). Arthropod roadkill for Lepidoptera, Orthoptera, and Hymenoptera were all significantly higher in the Central Funnel, but no significant differences between the funnels were seen in the lower



roadkill found among Odonata and Coleoptera. Lepidoptera comprised the majority of arthropod roadkill in both the Central Funnel (70%, 12 species) and Coastal Funnel (86%, 8 species) (Table 2, Fig. 3A). Nymphalidae (59%) dominated Lepidoptera roadkill in the Central Funnel, followed by Pieridae (sulphurs, *Colias* spp.) (39%). Sulphurs and nymphalids were similar in percentage for the Coastal Funnel (47% and 43%, respectively) (Table 2, Figs. 4A, 5). Monarchs comprised the majority of Lepidoptera roadkill in the Central Funnel (33%), and monarch roadkill was significantly higher in the Central Funnel compared to the Coastal Funnel (Table 2, Fig. 4A). Orange sulphurs dominated roadkill in the Coastal Funnel (34%). Gulf fritillary and overall nymphalid roadkill was also significantly higher in the Central Funnel compared to the Coastal Funnel (Table 2, Figs. 4A, 5).

The spatial distribution of road mortality among major arthropod taxa in the Central Funnel often tended to coincide (Fig. 6). Estimated roadkill per transect for Lepidoptera and Orthoptera were significantly weakly positively correlated in the Central Funnel ( $r_s = 0.21$ ;  $P = 0.03$ ), but not the Coastal Funnel ( $r_s = -0.07$ ;  $P = 0.65$ ). Significant weak positive correlations were found among all major taxa of Lepidoptera in the Central Funnel, including among monarchs, gulf fritillaries, other nymphalids, and sulphurs ( $r_s = 0.27$ – $0.35$ ;  $P < 0.05$ ) (Table 3). Roadkill of gulf fritillaries and other nymphalids were significantly moderately positively correlated in the Coastal Funnel ( $r_s = 0.55$ ;  $P = 0.0004$ ) (Table 3).

Two monarch roadkill hotspots, where road mortality exceeded 10 monarchs per 100m, were found in the southwestern portion of the Central Funnel: (1) east of Sonora on Interstate highway 10 (Fig. 7), and (2) Sanderson Canyon on US highway 90 (Fig. 8) (Table 4). The Sanderson Canyon roadkill was associated with monarchs being disturbed and flying from a roost in a mesquite tree adjacent to the highway whenever cars passed by, as observed by bicyclist Sara Dykman on 13 October (Fig. 9A; Dykman 2019). Roadkill at the Sanderson Canyon site was counted on 11 December, two months after the initial roost observation (Fig. 9B).

Overall arthropod roadkill in the entire Central Funnel was estimated at 3 million, of which about 0.84 million and 0.74 million were sulphurs and monarchs, respectively. In the entire Coastal Funnel, overall arthropod roadkill was estimated at 0.8 million, with 0.55 and 0.14 million roadkill sulphurs and monarchs, respectively (Table 2). Estimates for roadkill in Texas represent a little over half of the total estimates for the Central and Coastal funnels (Table 2). Total monarch mortality at the two Central Funnel roadkill hotspots was estimated at around 300 individuals (Table 4).

## Discussion

### *Monarch Roadkill Estimates*

The estimated fall 2019 monarch road mortality over the entire Central Funnel of 0.74 million individuals is similar to the 0.81 million monarch roadkill estimated for the fall of 2017 (Tables 2, 4-5). Both of these estimates are much lower than the 2.82 and 5.96 million monarch roadkill in the Central Funnel estimated for 2016 and 2018, respectively (Table 5). Maximum roadkill in Central Funnel hotspot areas of 10 to 18 monarchs per 100m for 2019 is similar to the maximum of 11 per 100 km observed on IH-10 between Sonora and Junction in 2017 (Kantola et al. 2019). Maximum Central Funnel hotspot roadkill was much higher at 94 per 100 m on IH-10 west of Ozona in 2016 (derived from Kantola et al. 2019) and 48 per 100m on US-90 west of Comstock in 2018 (Tracy and Coulson 2019). Over several years of data, estimated monarch roadkill hotspot zone mortality as a percentage of total roadkill in Texas ranges from about 0% to 2% in both migratory funnels (Table 5). The percentage roadkill in hotspot zones in Mexico is expected to be much higher, where monarch roadkill density reached up to 451 per single 100 m transect edge in 2018 (Mora Alvarez et al. 2019). Roadkill as a percentage of the monarch overwintering population was 1.24% for the Central Funnel in 2019, which was similar to the 1.53% value for 2017, but much lower than the 4.68% and 3.79% values for 2018 and 2016, respectively. Over the four years from 2016 to 2019, estimates of monarch roadkill in the Texas portion of the Central Funnel fluctuated in alternate years between lower values of 0.7% to 0.8% of the overwintering population in 2017 and 2019 to values about three times higher, at 2.1% to 2.6% of the overwintering population in 2016 and 2018 (Table 5).

The estimated 0.14 million monarch roadkill in the Coastal Funnel in fall 2019 is about three times lower than the 0.41 million estimated roadkill for 2018 (Table 5). Maximum roadkill in the Coastal Funnel was 2 per 100m in 2019, which is much lower than the 60 per 100 m on the John F. Kennedy Memorial Causeway hotspot at Corpus Christi Bay in 2018 (derived from Tracy and Coulson 2019). Coastal Funnel roadkill as a percentage of the overwintering population is 0.23%, which is much lower than in the Central Funnel (1.24%), and similar in scale to the 0.32% value for the Coastal Funnel from 2018. Monarch roadkill as a percentage of the overwintering population for the Texas portion of the Coastal Funnel in 2018 and 2019 are about half that of the entire Coastal Funnel (Table 5).

Monarch roadkill of up to 18 specimens per 100 m persisted in transects over a 66-day period at the Sanderson Canyon hotspot zone (Fig. 9B), but many roadkill specimens were probably lost over this period. Munguira and Thomas (1992) reported a loss of 1 out of 50 roadkill butterflies (2%), or 98% persistence, over a two-week period in the United Kingdom, yielding a daily loss rate of 0.15% of butterfly roadkill. In contrast, Skórka (2016) dedicated an entire study to the persistence of butterfly roadkill in Poland,

and he reported only about 12% butterfly roadkill persisting after two days in the grassy right-of-way, which equates to a daily loss rate of around 63%. Monarch roadkill hotspots in the Central Funnel are generally in arid areas with less predators, such as red imported fire ants, which should favor a lower loss rate. Over a 66-day period, a 0.15% loss rate would total about 10% loss of the original roadkill. A loss rate of 63% of day would have led to 100% loss after six days at the Sanderson Canyon site, which was not seen. Assuming the Sanderson roadkill hotspot was originally around the maximum monarch roadkill observed in previous studies of 95 per 100 m in 2016 near Ozona (Kantola et al. 2019), a count of 18 per 100 m after 66 days would give a maximum daily loss rate of 2.5% for a total loss of 19%. We estimate that our actual daily loss rate is somewhere between 0.15% and 2.5%. Further studies should be done to determine the persistence of monarch carcasses in hot spot areas of the Central Funnel. We generally recorded fall 2019 roadkill within about one month of peak migration in order to balance between avoiding counts before peak migratory roadkill and limiting roadkill specimen loss, all in accordance with limitations for personnel travel in covering a large survey area every other week.

### *Arthropod Roadkill Taxa Composition*

About 70% and 86% of the fall 2019 arthropod roadkill seen in the Texas portion of the Central and Coastal funnels, respectively, was comprised of Lepidoptera, which is a figure much higher than the maximum 7%-35% seen in eight previous roadkill studies using roadside transects (Seibert and Conover 1991, Rao and Girish 2007, Yamada et al. 2010, Baxter-Gilbert et al. 2015, Cicort-Lucaciu et al. 2016, Sathish-Narayanan et al. 2016, Keilsohn et al. 2018, Jegnathan et al. 2018) (Figs. 3, 10). A unique study using vehicle grill-mounted sticky traps in Canada found roadkill was dominated by Diptera with roadkill for Lepidoptera and several other orders, including Odonata, representing only 0.23% (Martin et al. 2018) (Fig. A.1A). Sticky trap surveys are probably more suited to sampling smaller bodied insects, such as many Diptera, that would be harder to detect on roadsides (c.f., Rao and Girish 2007) and most of which are probably destroyed or smashed against the vehicle upon impact. Larger-bodied insects, such as many Odonata and Lepidoptera are more likely to bounce off of a vehicle and remain intact for detection in roadside transect surveys (c.f., Seibert and Conover 1991, McKenna et al. 2001). A disadvantage of a grill-mounted sticky trap is that it can miss many arthropods that impact the vehicle windshield or roof.

Monarchs comprised about 33% and 19% of the total Lepidoptera roadkill in the fall of 2019 in the Texas Central and Coastal funnels, respectively (Fig. 4A-B). Subtracting the 23% of roadkill monarchs (33% monarchs x 70% Lepidoptera) from the total arthropod roadkill in the Central Funnel leaves 47% Lepidoptera roadkill, which is closer to, but still higher than, the maximum 35% Lepidoptera roadkill from previous studies. The fall

monarch migration dramatically increases the proportion of Lepidoptera roadkill in the Texas Central and Coastal funnels compared to other studies.

Nymphalidae (including monarchs) comprised 43%-59% of the Lepidoptera roadkill in the Texas Central and Coastal Funnel, respectively (Fig. 4A-B, Table 2). These figures are similar to the 38-70% of nymphalids seen in nine other studies (Munguira and Thomas 1992; Yamada et al. 2010; Vadivalganan et al. 2012; Halbritter et al. 2015; Sony and Arun 2015; Sathish-Narayanan et al. 2016; Skórka et al. 2013, 2018; Gaudel et al. 2020) (Figs. 4D; 11B-D, F; A.3A-C,E). This study had higher nymphalid roadkill compared to the 6%-31% nymphalids found in five other studies (Seibert and Conover 1991, McKenna et al. 2001, Karve 2008, Yamada et al. 2010, Keilsohn et al. 2018) (Figs. 4C, E; 11E; A.2A-C; A.3D). In contrast to monarchs comprising 33% and 19% of the fall Lepidoptera roadkill in the Texas Central and Coastal funnels, monarchs consisted of only 5% and 3% of the roadkill Lepidoptera in the fall for Illinois (McKenna et al. 2001) and over the entire season for Florida (Halbritter et al. 2015), respectively (Fig. 4 A-D). This difference illustrates the concentration of monarchs in the Central and Coastal funnels of Texas compared to other areas in the US. Much higher proportions of fall migrating monarchs in Lepidoptera roadkill would be expected in Mexico, where higher monarch roadkill rates have been observed (Mora Alvarez et al. 2019).

### *Migratory Butterfly Roadkill Prevalence*

The three most abundant butterfly species in addition to monarchs observed in our fall 2019 roadkill transects all exhibit fall migratory behavior in the eastern US, including gulf fritillaries, *Agraulis vanillae* (Nymphalidae, Heliconiinae), in Florida (Arbogast 1966; Walker 1978, 1991, 2001), orange sulphurs, *Colias eurytheme* (Pieridae), in Nebraska (Fisher 1944) and New Jersey (Schweitzer 2006), clouded sulphurs, *Colias philodice* (Pieridae), in Nebraska (Fisher 1944), and queen butterflies in South Texas and northern Mexico (Glassberg 1999, Einem 2003) (Table 2, Figs. 4A-B; 6C-F, A.4). Only migratory behavior of queen three butterflies has been reported in Texas. The frequency as roadkill for the other migratory butterfly species and their degree of spatial correlation among one another and monarchs, especially in arid areas of southwest Texas which are probably poor habitat for their larval host plants (Figs. 6C-F; A.4A), may be the result of common migratory pathways across roads. High proportions of roadkill from all fall migrating Lepidoptera, including sulphurs, gulf fritillaries, and queens (Table 2, Fig. 4A-B), contributes to the higher proportion of Lepidoptera represented in both fall Texas Central and Coastal funnel roadkill.

American snout butterflies, *Libytheana carinenta* (Nymphalidae: Libytheinae), commonly have mass migration flights in south Texas in the fall (Gilbert 1985; as *L. bachmanii*) that can lead to large amounts of roadkill (e.g., Blumenthal 2006). While a few American snout roadkill have been reported in iNaturalist for September to October in the Texas Coastal Funnel (iNaturalist 2020b), this species was not recorded in any of our roadkill

transects. Common buckeyes, *Junonia coenia* (Nymphalidae: Nymphalinae), also migrate in the fall in Florida (Walker 1978, 1991, 2001), but there is only a single reported fall roadkill in the Texas Central Funnel from iNaturalist (2020c), and none in this study.

Migratory butterflies, including monarchs, gulf fritillaries, sulphurs, and queens, represented 91% of the Lepidoptera roadkill in the Central Funnel, and 86% of Lepidoptera in the Coastal Funnel (Table 2, Fig. 4A-B). In Illinois (McKenna et al. 2001) and Florida (Halbritter et al. 2015), migratory species made up about 88% and 72% of the Lepidoptera roadkill, respectively (Figs. 4C-D). Migrants in Florida included the pierids *Phoebis sennae* and *Abaeis nicippe* (Walker 2001). In contrast, moths, rather than migratory butterflies, dominated Lepidoptera roadkill in Ohio (62%) (Seibert and Conover 1991) and northeastern US woodlands (Keilsohn et al. 2018) (Figs. 4E,A.2C). In Europe, migratory butterflies comprised 54% and 23% of the Lepidoptera roadkill in the United Kingdom (Munguira and Thomas 1992) and Poland (Skorka et al. 2018), respectively (Fig. A.3. A-B). European roadkill migrant butterflies were represented by small tortoiseshells (Nymphalidae) and three *Pieris* spp. (Pieridae), *P. brassicae*, *P. rapae*, and *P. napi* (Baker 1969, Spieth and Cordes 2012). Many of these roadkill studies extended over most of the growing season, but the three with the highest migratory butterfly roadkill compositions (86-91%), including our Central and Coastal funnel studies and that of McKenna et al. (2003), were restricted to the fall, which should include more fall migrants.

In India, a similar pattern of a high percentage of migrant butterflies have been reported from a variety of roadkill studies. Rao and Girish (2007) noted that migratory species may have contributed to the high proportions of Lepidoptera and Odonata in their arthropod roadkill study. Their reported roadkill Lepidoptera was dominated by two migratory pierids, *Catopsilia pomona* and *Eurema hecabe* (migratory status discussed below), and roadkill Odonata were dominated by migratory *Pantala flavescens* (c.f., Troast et al. 2016) (Fig. 10A; species percentages not provided). Saraf and Jadesh (2017) reported that the eight most common of 35 species of Lepidoptera roadkill in their study in India included three migratory species, two danaines, *Tirumala septentrionis*, *Euploea core*, and the pierid *Eurema hecabe* (180 roadkill butterflies total, species percentages not provided). High percentages of migratory butterfly species were reported among roadkill Lepidoptera in four of six Indian studies: 96% (Roshnath and Cyriac 2013), 66% (Sony and Arun 2015), 69% (Sathish-Narahyanan et al. 2016), and 70% (Karve 2008) (Fig. 11A-C, D). Migrant butterflies only comprised 21% and 23% of the roadkill Lepidoptera in Nepalese and Indian studies by Gaudel et al. (2020) and Vadivalganan et al. (2012), respectively (Fig. 11D,F). The eight migratory butterfly species reported as common in all of the Indian roadkill studies described above include four danaines, *Euploea core*, *E. sylvester*, *Tirumala septentrionis*, *T. limniaceae* (*Danaus* spp. do not migrate in India; Bhaumik and Kunte 2017), three pierids, *Catopsilia pomona* (Bharos 2000, Ramesh et al. 2013), *C. pyranthe* (Ramesh et al. 2013), and *Eurema hecabe*



(= *Terias hecabe*; Williams 1930, Yata 1995 in India; Williams 1923, 1933 in Sri Lanka; Nielson 2015 in Australia), and a papilionid, *Papilio demoleus* (Ramesh et al. 2013) (Fig. 11). The highest percent roadkill was reported for *Tirumala septentrionis* on 13 October, 2013 (86%; Roshnath and Cyriac 2013) (Fig. 11A) and 28/31 May, 2013 (61%; Sony and Arun 2015) (Fig. 11B), corresponding to the fall and spring migration, respectively. Several of these Indian studies include roadkill survey data over multiple seasons, which probably dilutes the magnitude of the percent contribution of migratory butterfly roadkill incidence (Fig. 11C,F). In southern Taiwan, up to 3-4% of four *Euploea* spp., *E. sylvester swinhoei*, *E. mulciber barsine*, *E. eunice hobsoni*, *E. tulliolus koxinga*, suffer road mortality during the spring crossing of a roadkill hotspot without mitigation measures (Taiwan Area National Freeway Bureau 2015). In contrast, migratory butterflies are notably absent in Lepidoptera roadkill reported from Japan (Fig. A.3 D-E). Seasonal movements of migratory butterflies can render them especially susceptible to roadkill in North American and Asia.

The *Roadkills of Texas* iNaturalist project (iNaturalist 2020d) records arthropod roadkill for several additional species than found in our study, many of which occurred in the spring or summer. Their more common roadkill species included pipevine swallowtails, *Battus philenor*, and the green darner dragonfly, *Anax junius* (Aeshnidae), another migratory species (Wikelski et al. 2006). Dragonfly roadkill remnants found in this study consisted mostly of wings that were not identified to species. Further field observations during additional fall seasons and across other seasons are needed to understand the spatio-temporal variability in arthropod roadkill for Texas.

## Conclusion

The four years of current data indicate that monarch road mortality in the Texas portion of the Central Funnel can comprise as much as around 2-3% of the overwintering population in some years, and only 0.4-0.5% of the overwintering population in other years (Table 5). Annual monarch road mortality in Texas Central Funnel averages around 1.4% of the overwintering population over four years. Long-term occurrence 1.4% mortality can be a significant factor contributing to the annual 7% population decline in monarchs (c.f., Kantola et al. 2019). Even with 100% effective direct roadkill mitigation at monarch roadkill hotspot zones, a maximum of only about 5% of Texas monarch roadkill (0.2% of overwintering population in 2016 Central Funnel) would be reduced in each migratory funnel. Consequently, compensatory mitigation may be more promising if it can potentially boost annual monarch populations by at least 1.4% of the overwintering population. The amount of spring and fall milkweed and monarch population production along Texas roadsides should be quantified in order to estimate their potential contribution to compensatory mitigation. Steps to conserve or increase the amount of spring and fall milkweed nectar/larval host plants and fall nectar plants should be considered. Compensatory mitigation to increase nectar resources can also

benefit other Texas migratory butterflies subject to road mortality, including gulf fritillaries, sulphurs, and queens.

## Tables

**Table 1. Arthropod roadkill counts for 100 m transects spatially thinned to 10 km and kilometer length by Federal Highway Administration (FHWA) road classifications for fall 2019 in Texas for central and coastal monarch migratory funnels.**

Migratory Funnel	Estimated Roadkill per 100 m Transect (Mean $\pm$ SD) by FHWA Road Classification <sup>a</sup>			
	Interstates and Freeways	Other Principal Arterials	Minor Arterials	Total
Central	2.93 $\pm$ 1.55 (51)a	3.28 $\pm$ 5.59 (48)a	1.06 $\pm$ 2.03 (6)a	
Coastal	1.03 $\pm$ 2.11 (28)a	0.23 $\pm$ 0.61 (14)a	0.00 $\pm$ 0.00 (3)a	
	Roadway Lengths for Entire Funnels (US and Mexico) or Texas Portion of Funnel (km)			
Central	32,610	28,519	42,995	104,124
Texas Central	18,164	15,690	23,914	57,768
Coastal	15,164	11,719	29,367	56,250
Texas Coastal	9,105	6,325	14,286	29,716

<sup>a</sup>Mean roadkill counts in the same row with the same letter are not significantly different ( $P < 0.05$ ; Kruskal-Wallis test).

**Table 2. Arthropod roadkill counts (includes extrapolations to uncounted sides) by various taxa for fall 2019 in monarch fall migratory Central and Coastal funnels of Texas for 100m transects spatially thinned to 10 km.<sup>a</sup>**

Taxa/Species	Roadkill Counts (Percent of Taxa) – Sum from Thinned Transects		Roadkill per 100 m Transect (Mean ± SD) <sup>b</sup>		Estimated Total Roadkill = (Estimated Roadkill per 100 m x 10) * Km Length Highways <sup>c</sup>			
	Central Funnel	Coastal Funnel	Central Funnel (n = 107)	Coastal Funnel (n = 46)	Central Funnel	Coastal Funnel	Texas Central Funnel	Texas Coastal Funnel
<i>Arthropods</i>	321	36	2.93 ± 4.94a	0.79 ± 2.32b	3,046,843	442,663	1,690,389	233,852
Lepidoptera	222 (69%)	31 (86%)	2.07 ± 4.17a	0.67 ± 2.28b	2,159,940	378,832	1,198,335	200,131
Orthoptera	64 (20%)	2 (5%)	0.60 ± 2.64a	0.04 ± 0.25b	626,982	20,421	347,850	10,788
Hymenoptera	26 (8%)	2 (5%)	0.24 ± 0.71a	0.04 ± 0.25b	250,190	20,421	138,805	10,788
Odonata	5 (2%)	2 (5%)	0.05 ± 0.30a	0.04 ± 0.25a	51,965	20,421	28,830	10,788
Coleoptera	4 (1%)	0 (0%)	0.03 ± 0.25a	0.00 ± 0.00a	35,714	0	19,814	0
<i>Lepidoptera Taxa</i>								
<i>Nymphalidae</i>	137 (59%)	14 (43%)	1.24 ± 3.00a	0.28 ± 1.00b	1,291,721	155,543	716,647	82,171
Monarch ( <i>Danaus plexippus</i> )	76 (33%)	6 (19%)	0.71 ± 2.15a	0.13 ± 0.50b	738,307	73,370	409,613	38,760
Gulf Fritillary ( <i>Agraulis vanillae</i> )	38 (16%)	1 (4%)	0.35 ± 1.10a	0.03 ± 0.17b	368,618	14,429	204,510	7,623
Goatweed Butterfly ( <i>Anaea andria</i> )	11 (5%)	0 (0%)	0.10 ± 0.54a	0.00 ± 0.00a	103,346	0	57,336	0
Queen ( <i>Danaus gilippus</i> )	7 (3%)	5 (16%)	0.06 ± 0.26a	0.11 ± 0.61a	65,394	63,342	36,280	33,463
Elada Checkerspot ( <i>Texola elada</i> )	4 (2%)	0 (0%)	0.04 ± 0.23a	0.00 ± 0.00a	38,925	0	21,596	0
Red Admiral ( <i>Vanessa atalanta</i> )	1 (1%)	0 (0%)	0.01 ± 0.11a	0.00 ± 0.00a	11,483	0	6,371	0
Question Mark ( <i>Polygonia interrogatoris</i> )	1 (1%)	1 (4%)	0.01 ± 0.11a	0.03 ± 0.17a	11,483	14,429	6,371	7,623
<i>Pieridae</i>	91 (39%)	15 (47%)	0.80 ± 2.08a	0.33 ± 1.26a	837,274	184,402	464,520	97,417
Orange Sulphur ( <i>Colias eurytheme</i> )	57 (25%)	11 (34%)	0.53 ± 1.64a	0.23 ± 0.84a	555,263	131,087	308,060	69,251
Clouded Sulphur ( <i>Colias philodice</i> )	27 (12%)	4 (14%)	0.26 ± 0.81a	0.09 ± 0.45a	267,025	53,315	148,145	28,166
Unidentified Sulphurs (above <i>Colias</i> spp.)	7 (3%)	0 (0%)	0.06 ± 0.41a	0.00 ± 0.00a	65,394	0	36,280	0
<i>Papilionidae</i>								
Swallowtails ( <i>Papilio</i> spp.)	2 (1%)	2 (6%)	0.02 ± 0.14a	0.04 ± 0.29a	19,462	24,457	10,798	12,920
<i>Heterocera</i> (moths)	1 (1%)	1 (4%)	0.01 ± 0.11a	0.03 ± 0.17a	11,483	14,429	6,371	7,623

<sup>a</sup>See text for ratios used to extrapolate roadkill counts on unsampled side of roadway from sampled side.

<sup>b</sup>Paired mean roadkill counts for a given butterfly taxon for either single or both roadsides with the same letter are not significantly different (P < 0.05; Welch's t-test).

<sup>c</sup>Length of highways from Table 1.

**Table 3. Lepidoptera roadkill spatial correlations for fall 2019 in monarch fall migratory Central and Coastal funnels of Texas for 100m transects spatially thinned to 10 km.<sup>a</sup>**

<i>Central Funnel</i>	Monarch	Gulf Fritillary	Other Nymphalidae <sup>b</sup>	Sulphurs
Monarch	1.00	0.30*	0.32*	0.29*
Gulf Fritillary		1.00	0.35*	0.33*
Other Nymphalidae			1.00	0.27*
Pieridae				1.00
<i>Coastal Funnel</i>				
Monarch	1.00	-0.04	0.30	0.25
Gulf Fritillary		1.00	0.55*	-0.05
Other Nymphalidae			1.00	0.27
Sulphurs				1.00

<sup>a</sup>Asterisks indicate significant correlation ( $P < 0.05$ ; paired Spearman rank order correlations with Holm's correction for multiple comparisons per migratory funnel).

<sup>b</sup>Nymphalidae other than monarchs and gulf fritillaries (see Table 2).



**Table 4. Monarch roadkill counts and total estimates for hotspots in the Texas Central Funnel in the fall of 2019, for entire and Texas portions of Central and Coastal funnels for fall 2018, and for entire and Texas portion of Central Funnel for 2016-2017.**

Location	Roadkill per 100 m Transect Mean $\pm$ SD (n)	Length (km) <sup>a</sup>	Estimated Total Roadkill = (Estimated Roadkill per 100 m x 10) * Km Length Highways
<i>Fall 2019 Central Funnel Hotspots</i>			
Sonora, 5 km East on Interstate Highway 10	9.75 $\pm$ 2.50 (4)	2.67	260
Sanderson Canyon at US Highway 90	17.50 $\pm$ 2.12 (2)	0.22	39
Total			299
<i>Fall 2018 Monarch Migratory Funnels (derived from Tracy and Coulson 2019)</i>			
Central Funnel	5.73 $\pm$ 8.64 (79)	104,124	5,966,305
Texas Central Funnel	"	57,768	3,310,106
Coastal Funnel	0.72 $\pm$ 1.94 (73)	56,250	405,000
Texas Coastal Funnel	"	29,716	213,955
<i>Fall 2017 Monarch Migratory Funnels (derived from Kantola et al. 2019)</i>			
Central Funnel	0.77 $\pm$ 1.53 (75)	104,124	801,755
Texas Central Funnel	"	57,768	444,814
<i>Fall 2016 Monarch Migratory Funnels (derived from Kantola et al. 2019)</i>			
Central Funnel	2.24 $\pm$ 6.24 (75)	104,124	2,332,378
Texas Central Funnel	"	57,768	1,294,003

<sup>a</sup>Lengths of highways from Figs. 7-8 and Table 1.

**Table 5. Estimated monarch roadkill over portions of migratory funnels in relation to overwintering estimates.**

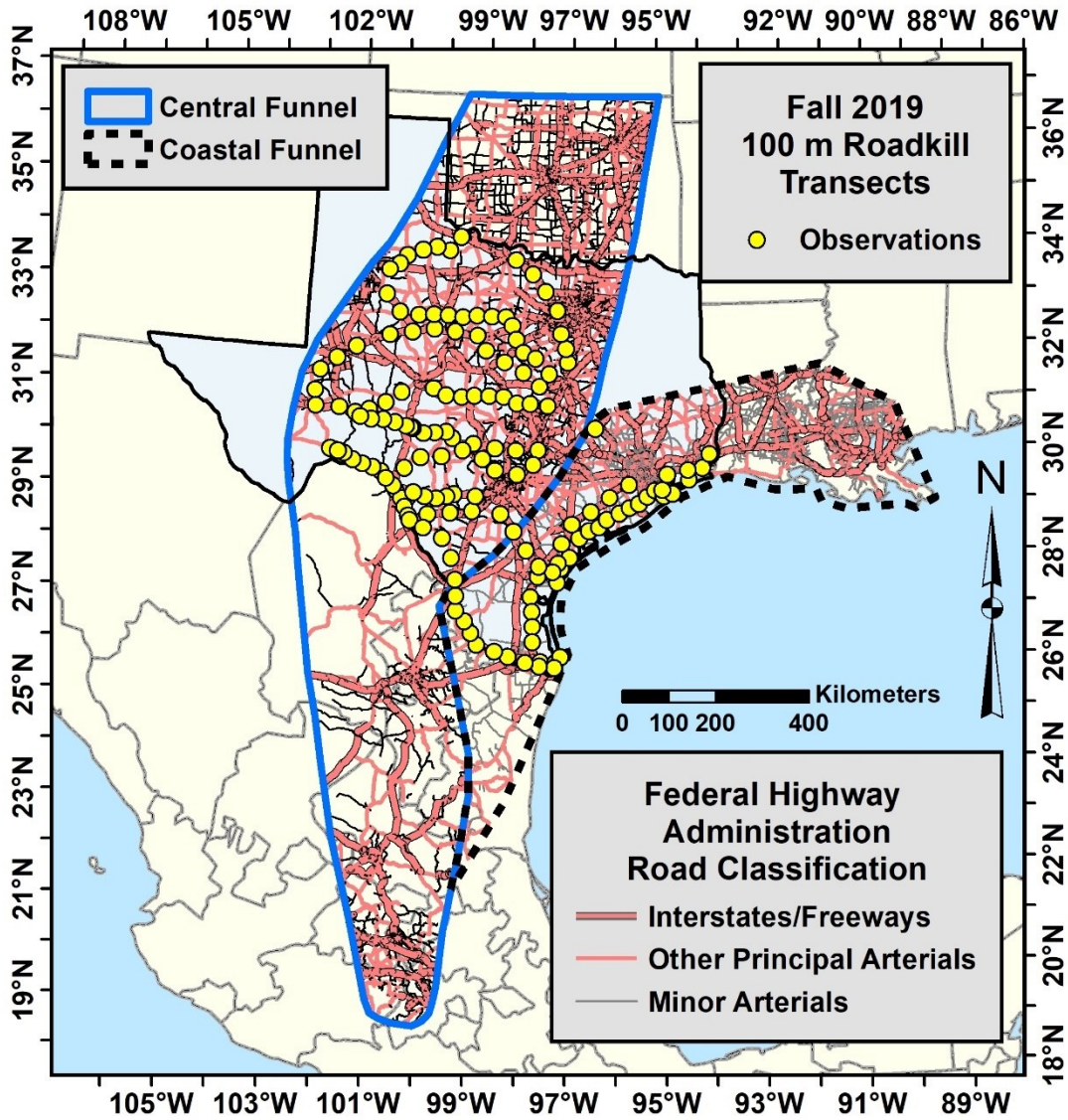
Year/ Location	Thinned Presence/ Absence Roadkill/ 100m	Estimated Roadkill (millions) <sup>a</sup>		Hotspot Zone Roadkill as Percent of Total for Texas	Hotspot Zone Roadkill as Percent of Total for Texas	Area Monarchs Over- wintering in Mexico (Monarch Watch 2020)	Estimated Over- wintering (millions) <sup>c</sup>	Roadkill as Percent Overwintering Population	
		Entire Funnel	Texas Portion					Hotspot Zone Areas (not included in Totals) <sup>b</sup>	Central Funnel
<i>Central Funnel</i>									
2016	2.7127	2.82	1.57	75,691	4.85%	2.91	61.401	4.60%	2.55%
2017	0.7737	0.81	0.45	0	0.00%	2.48	52.328	1.54%	0.85%
2018	5.7256	5.96	3.31	1,370	0.04%	6.05	127.655	4.67%	2.59%
2019	0.7091	0.74	0.41	299	0.07%	2.83	59.713	1.24%	0.69%
<i>Coastal Funnel</i>									
2018	0.7245	0.41	0.22	4,478	2.08%	6.05	127.655	0.32%	0.17%
2019	0.1304	0.07	0.04	0	0.00%	2.83	59.713	0.12%	0.06%

<sup>a</sup>Data from Tables 2 and 4.

<sup>b</sup>Data recalculated from average roadkill estimates per 100 m in hotspot zone multiplied by 10 and length of zone in km.

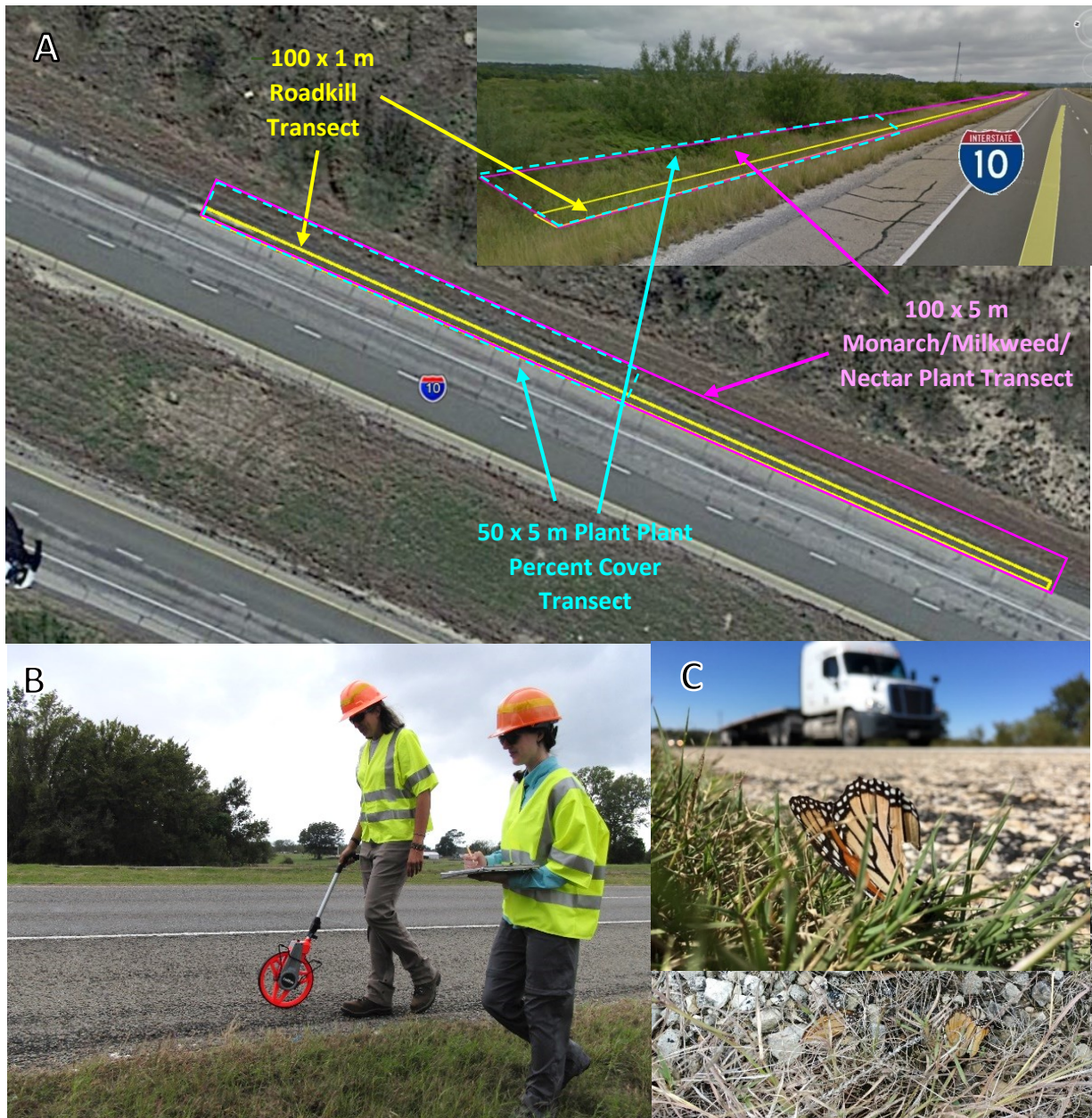
<sup>c</sup>Hectares monarchs x 21.1 million monarchs/ha, following Thogmartin et al. (2017).

## Figures



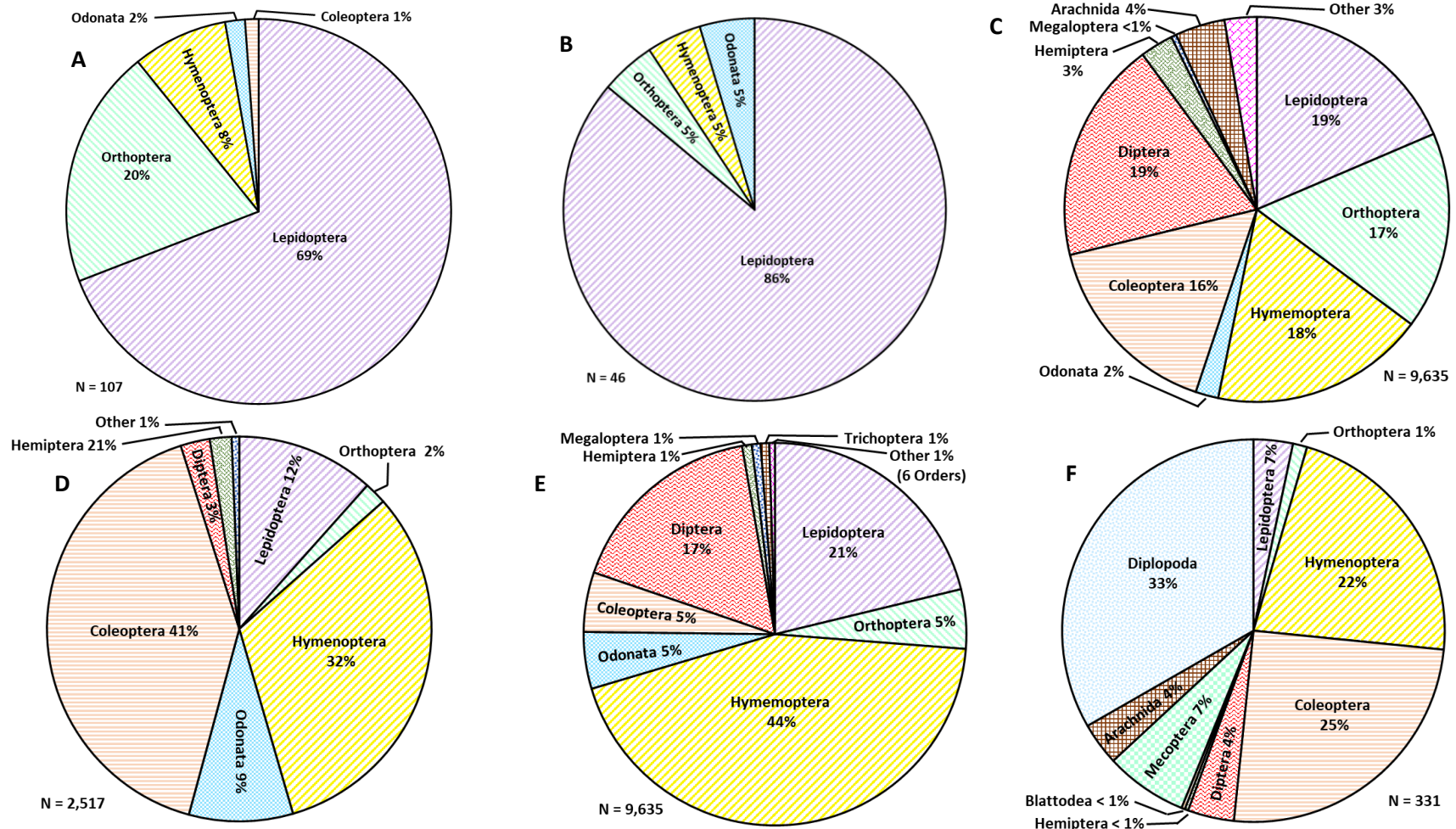
**Figure 1. Distribution of fall 2019 100 x 1 m roadkill transects over Texas roadways within the monarch migratory Central and Coastal funnels.**





**Figure 2. (A) Layout of 100 x 1 m roadkill transect (yellow), 100 x 5 m monarch/milkweed transect (pink), and 50 x 5 m plant percent cover transect (blue dashed). (B) Field assistants Janice Bovankovich (left) and Kaitlin Lopez (right) walking a 100 m transect. (C) Roadkill monarchs within transects along grassy edge of right of way.**





**Figure 3. Percentage roadkill among roadside transects for arthropod taxa in North America and Europe: (A) Texas Central Funnel, Oct-Nov 2019 (Table 2); (B) Texas Coastal Funnel, Nov-Dec 2019 (Table 2); (C) US highway 33, forest, Hocking River, Northwest Athens, Ohio, Jun 1987–Aug 1988 (Seibert and Conover 1991); (D) meadow roads in Delaware, Maryland, and Pennsylvania, Jun-Jul, 2015 (Keilsohn et al. 2018); (E) highway 69/100, forests/wetlands, Georgian Bay, Lake Huron, Ontario, Canada, May-Aug, 2012 (Baxter-Gilbert et al. 2015); (F) forest roads, Vâlsan river basin, Romania, 28 May/16 Sep 2015 (Cicort-Lucaciu et al. 2016) (see also Figs. 10, A.1).**



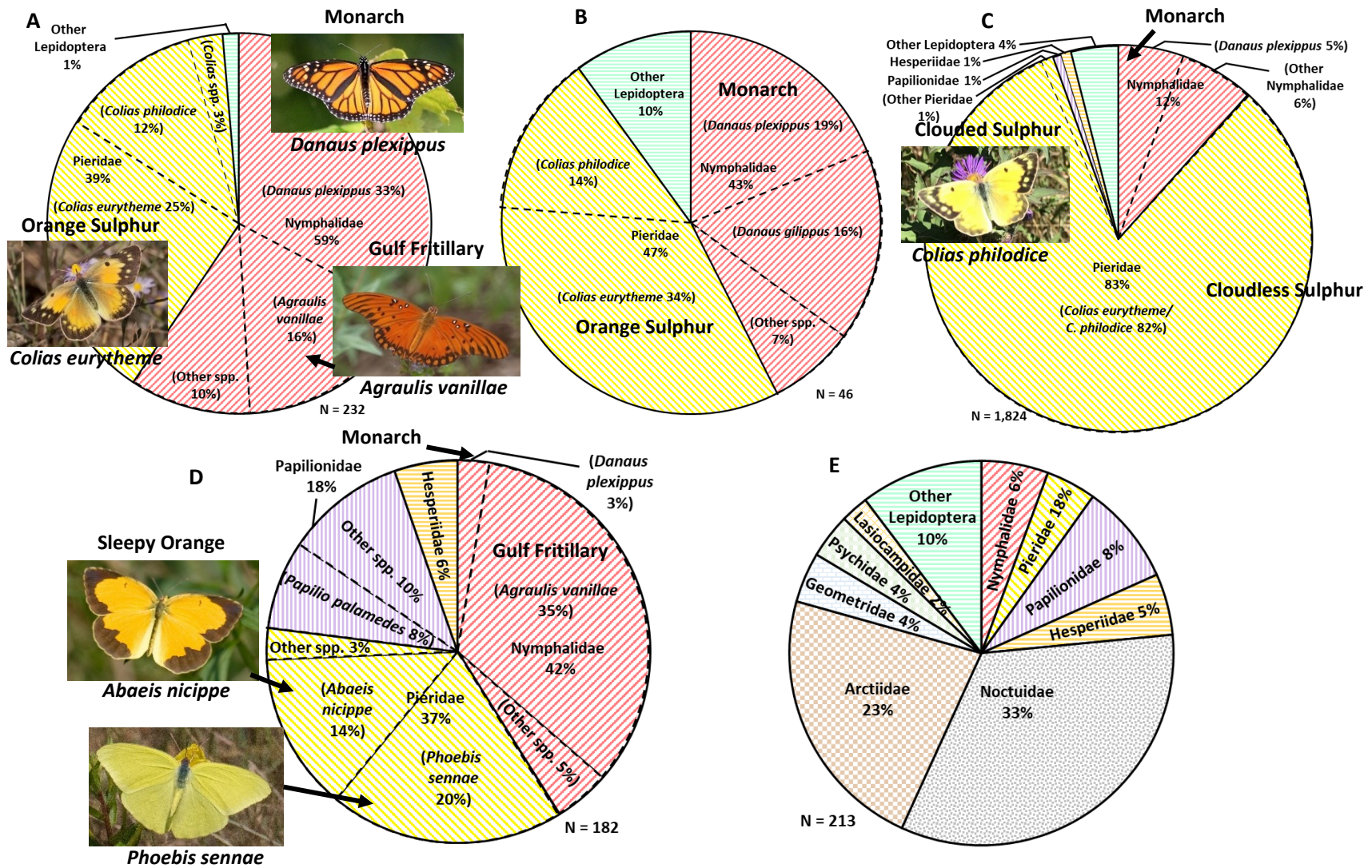


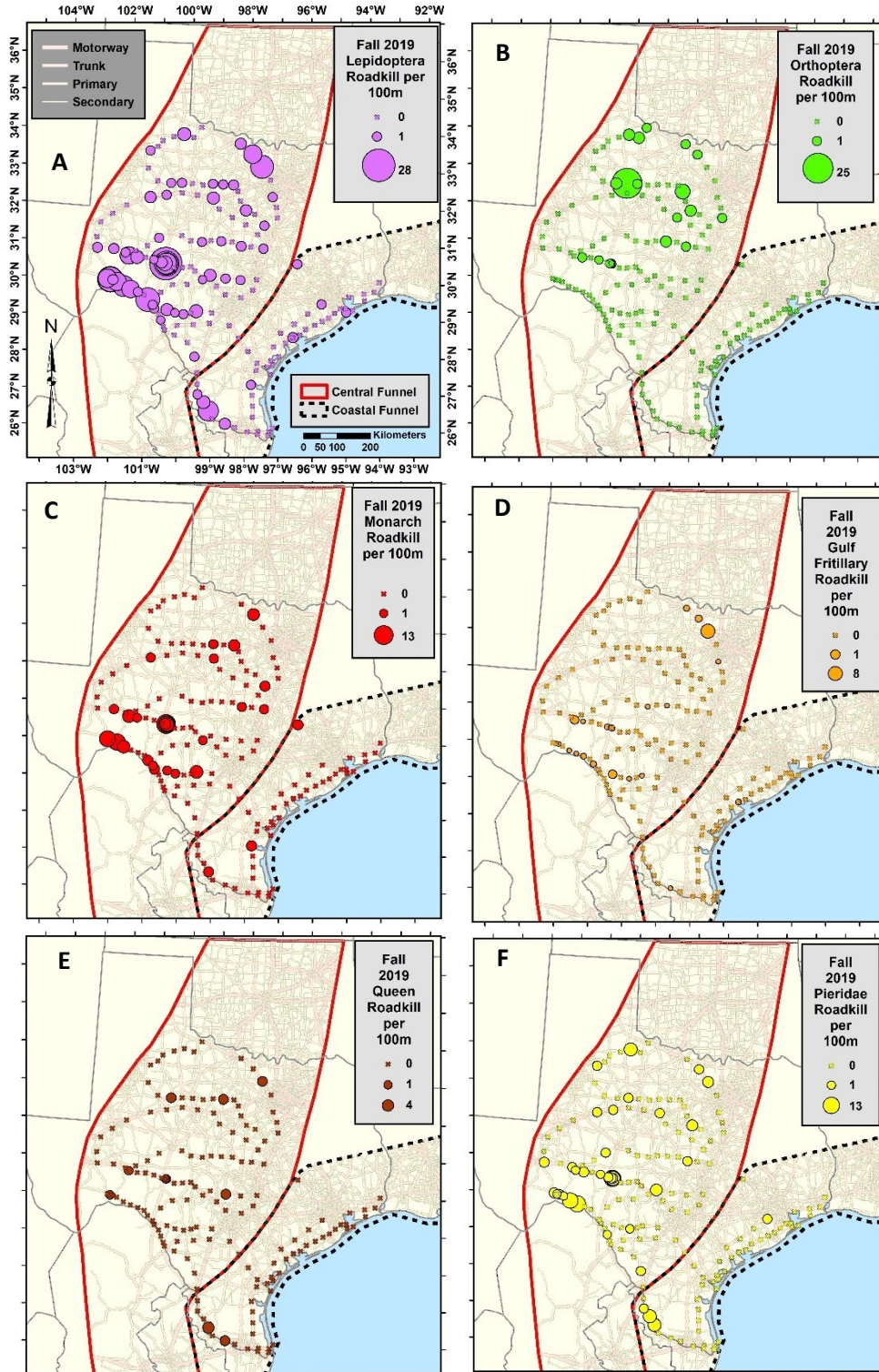
Figure 4. Percentage roadkill among roadside transects for Lepidoptera taxa: (A) Texas Central Funnel, Oct-Nov 2019 (Table 2); (B) Texas Coastal Funnel, Nov-Dec 2019 (Table 2); (C) Illinois, Aug-Oct, 1998 (McKenna et al. 2001); (D) Divided highways near Gainesville, Florida, Apr-Oct 2011 (Halbritter et al. 2015); (E) US highway 33, forest by Hocking River, Northwest Athens, Ohio, Jun 1987–Aug 1988 (Seibert and Conover 1991); (images: Alabama Butterfly Atlas 2020, iNaturalist 2020a) (see also Figs. 11, A.2-3).





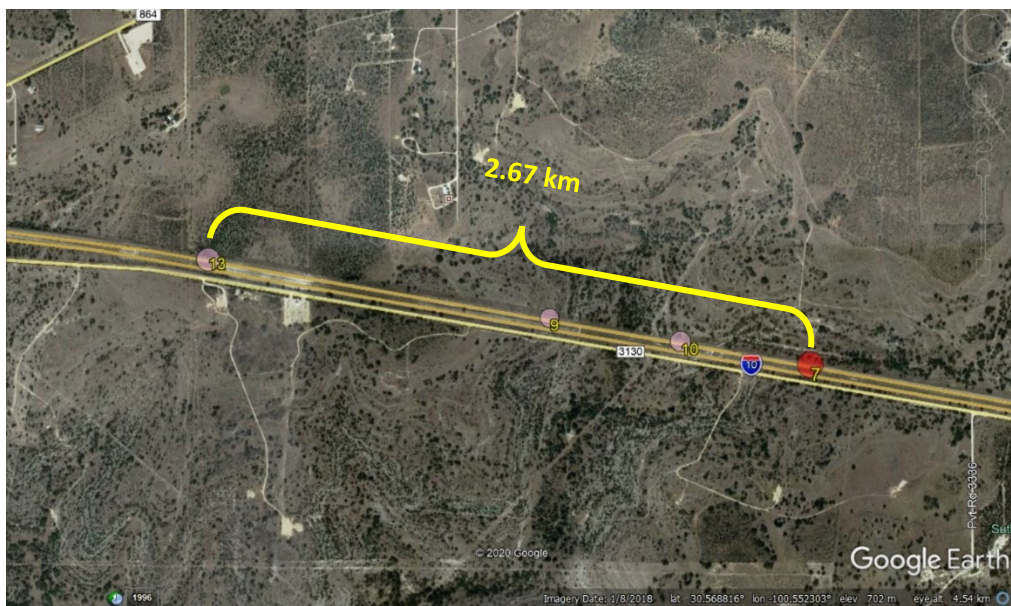
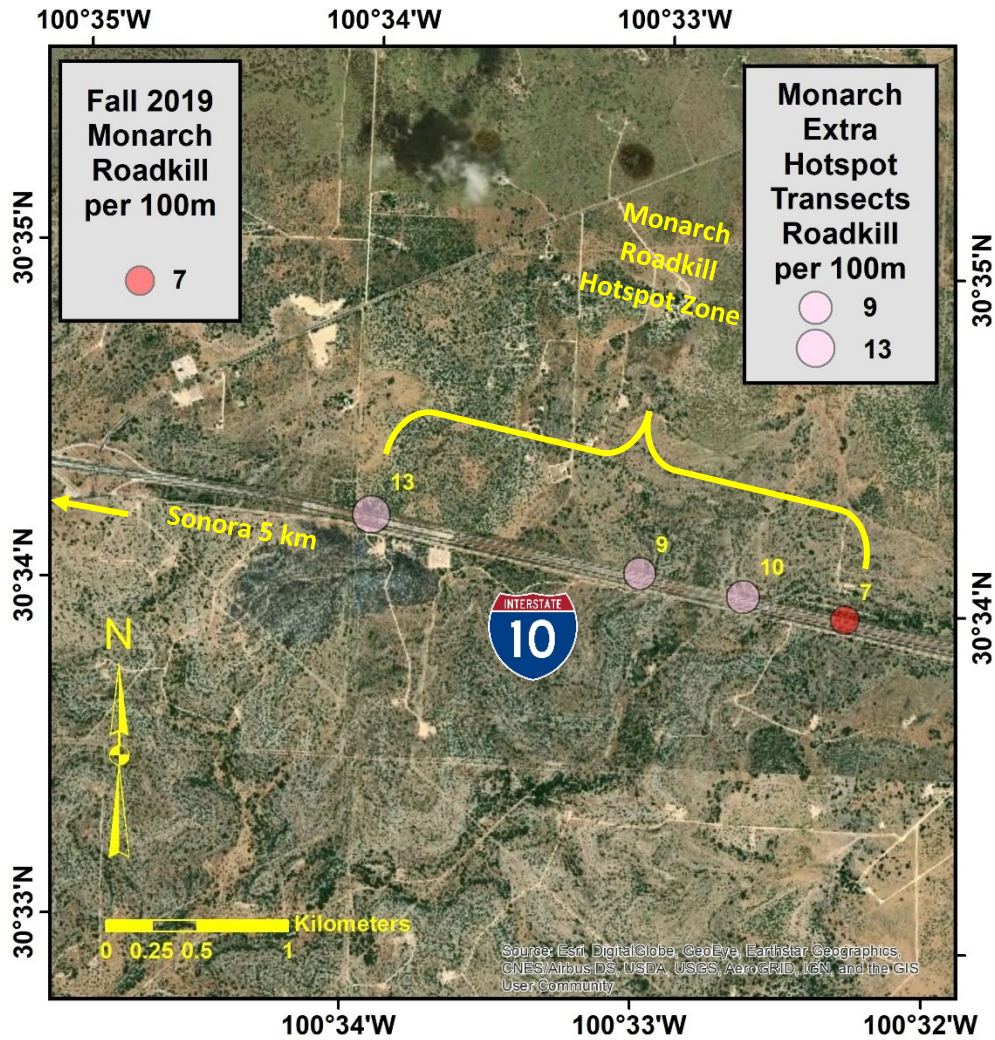
**Figure 5. Most common butterfly species in addition to monarchs as fall 2019 roadkill in the Texas Central and Coastal funnels: (A-F) Nymphalidae: (A) gulf fritillary, *Agraulis vanillae*; (B) goatweed butterfly, *Anaea andria*; (C) queen, *Danaus gilippus*; (D) elada checkerspot, *Texola elada*; (E) red admiral, *Vanessa atalanta*; (F) question mark, *Polygonia interrogationis*; (G-H) Pieridae: (G) orange sulphur, *Colias eurytheme*; and (H) clouded sulphur, *Colias philodice* (images, Alabama Butterfly Atlas 2020, iNaturalist 2020a).**





**Figure 6. Spatial distribution of roadkill per 100 m x 1 m transect (unthinned) for various arthropod taxa during the fall of 2019 within Texas monarch migratory funnels: (A) Lepidoptera; (B) Orthoptera; (C) monarchs; (D) gulf fritillaries; (E) queen butterflies; and (F) sulphurs (Pieridae) (see also Fig. A.4).**





**Figure 7. Monarch roadkill hotspot zone 5 km east of Sonora along Interstate Highway 10, sampled 12 November, 2019.**



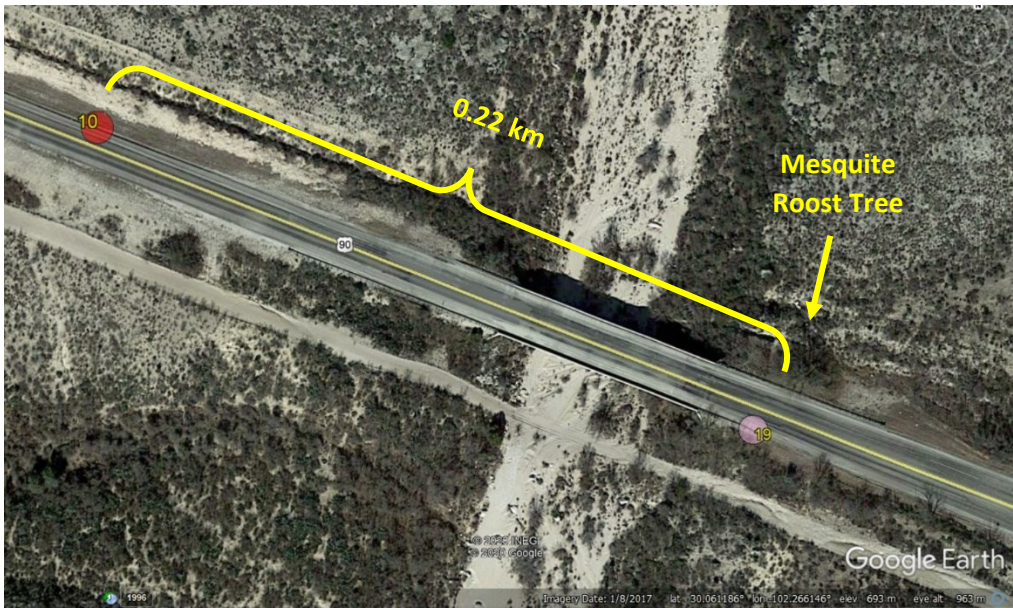
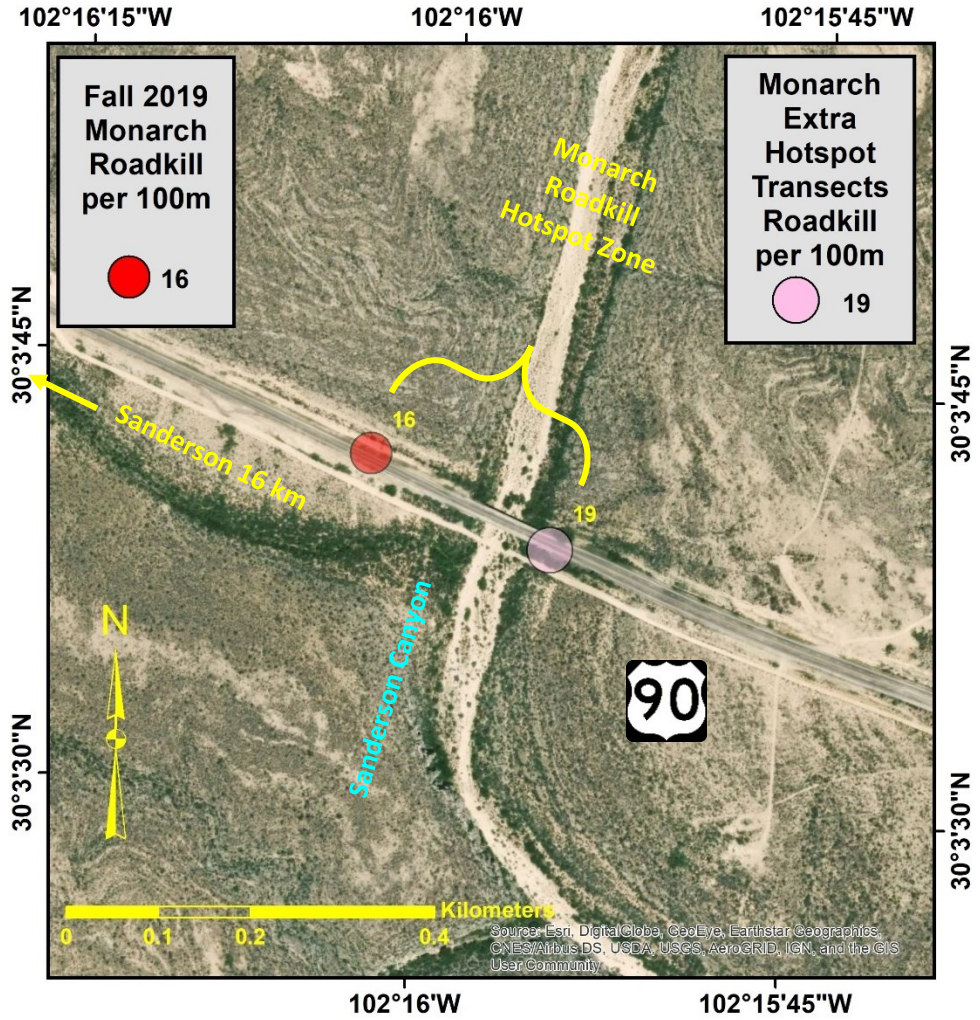
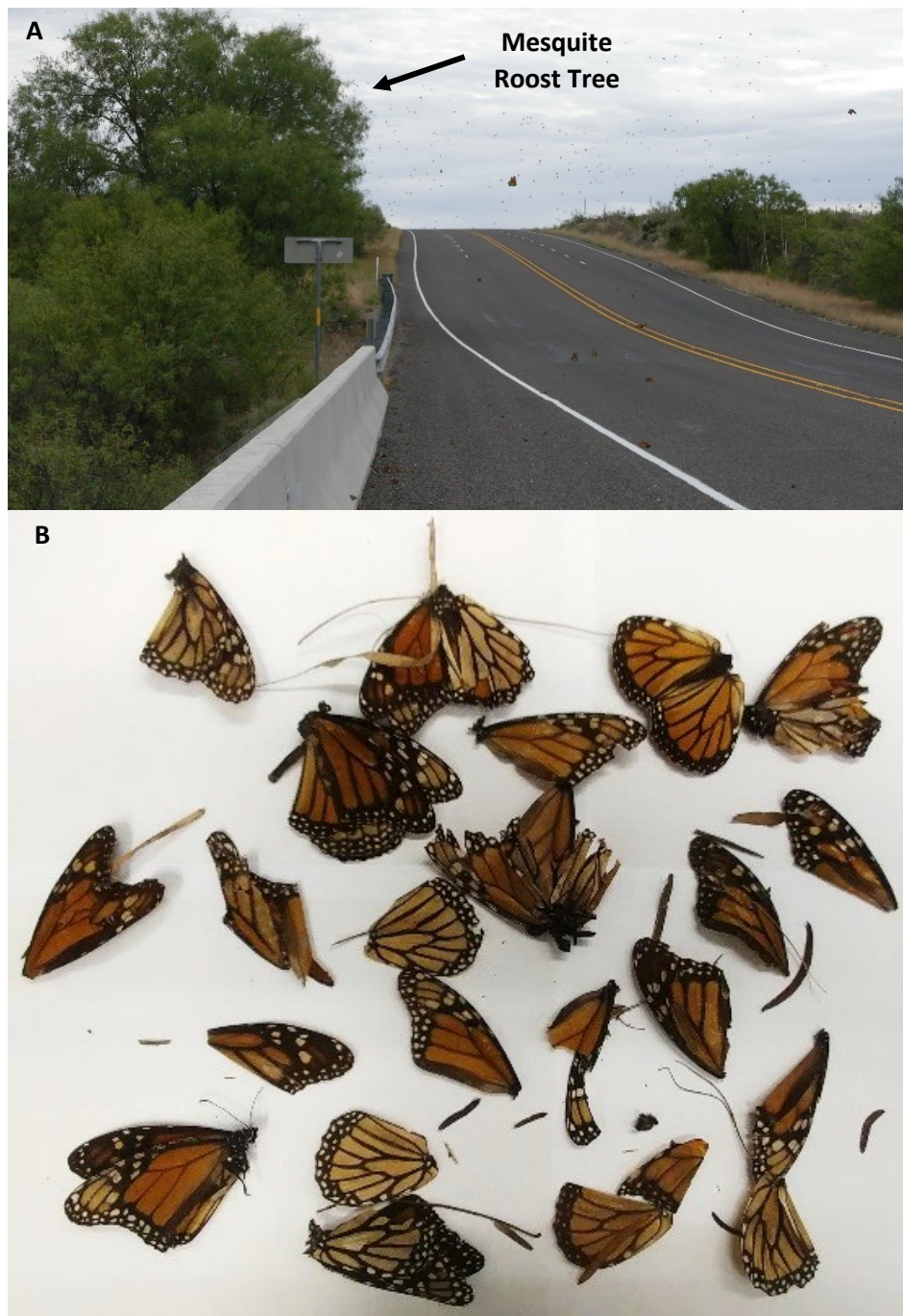
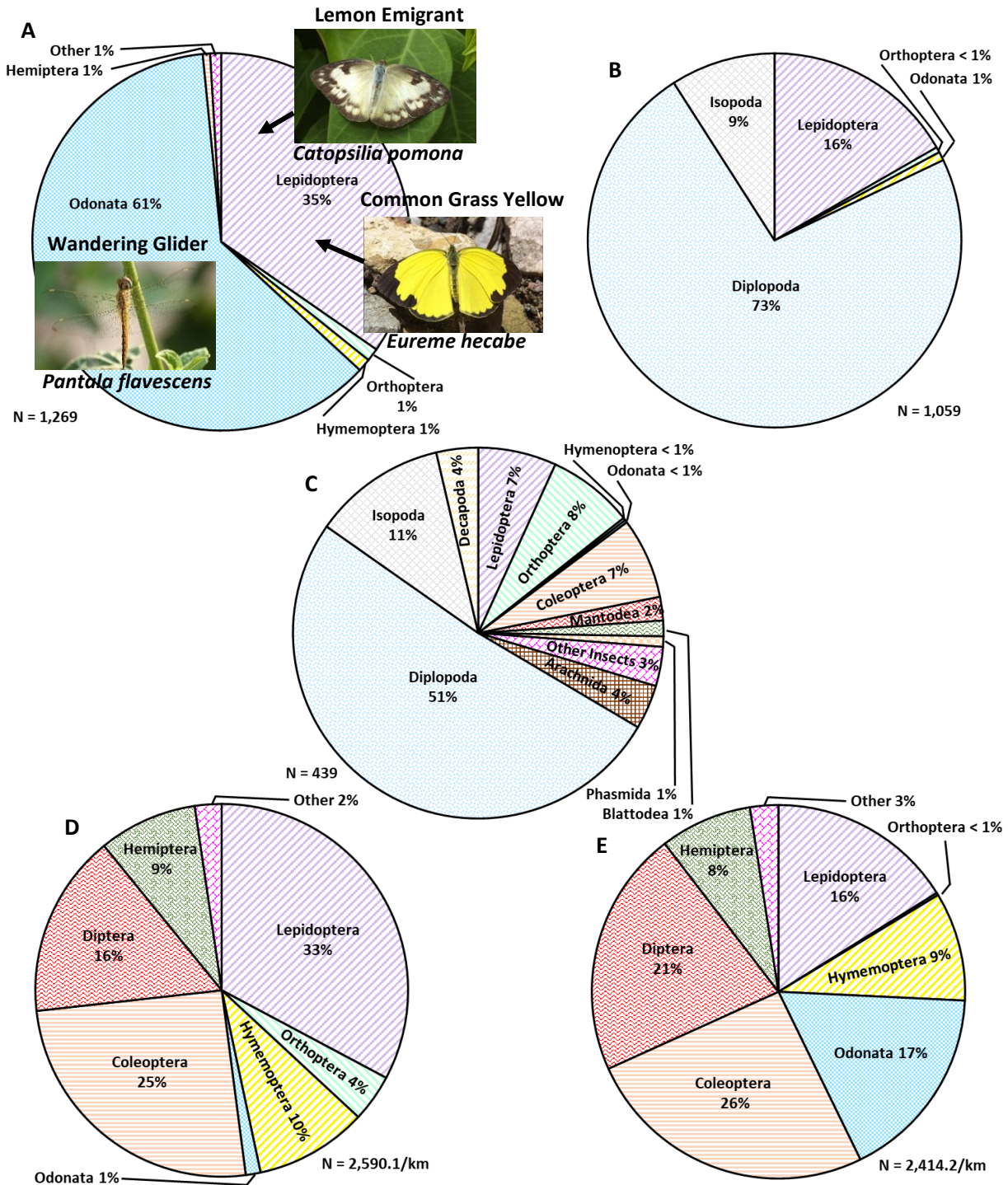


Figure 8. Monarch roadkill hotspot zone 16 km east of Sanderson along US Highway 90, sampled 11 December, 2019.



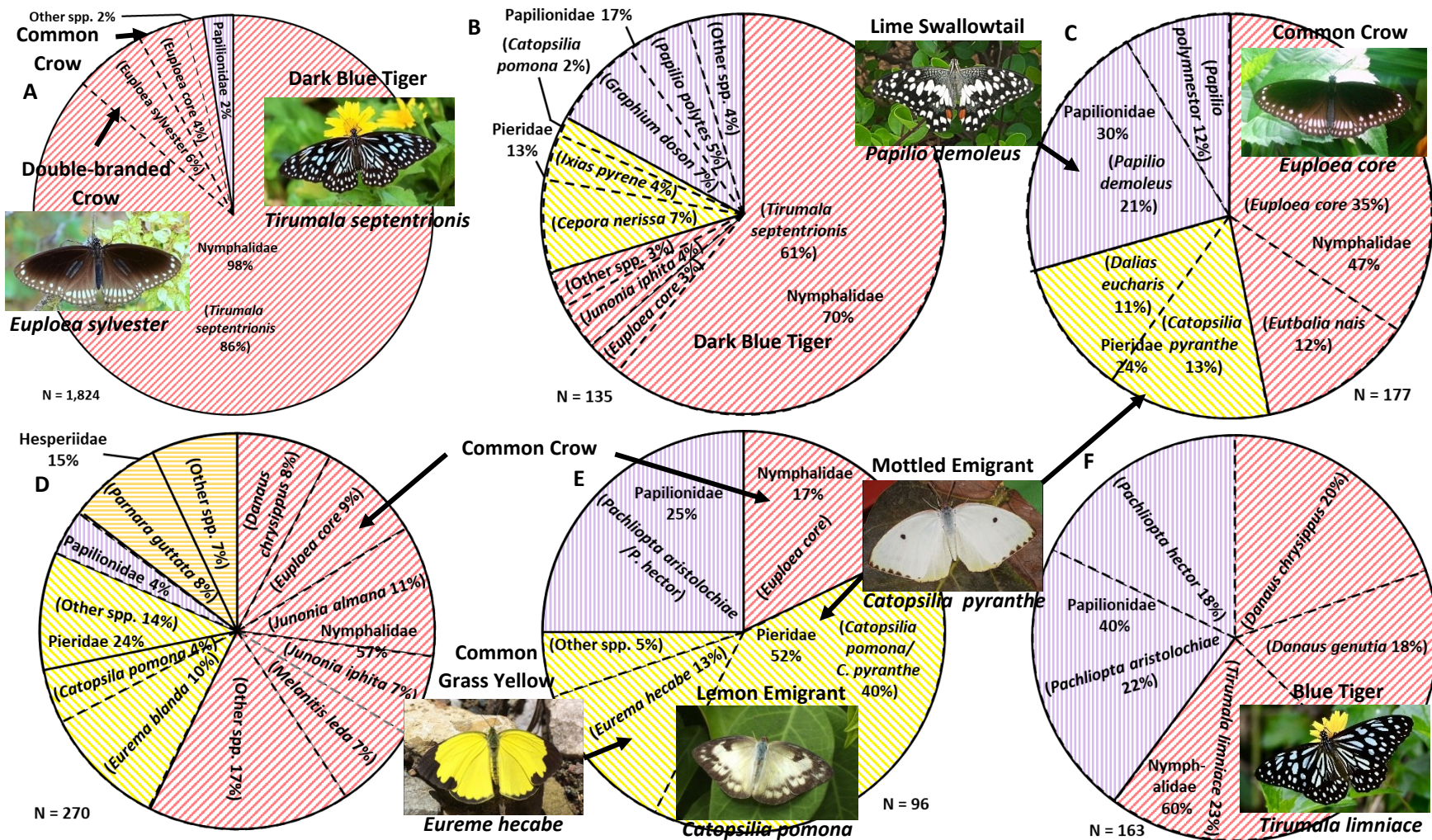


**Figure 9. (A) Monarchs flying from mesquite tree roost at roadkill hotspot zone about 16 km east of Sanderson along US Highway 90 on 13 October 2019 (Dykman 2019), and (B) 19 roadkill monarchs collected from transects on North and South side of road by mesquite roost tree on 11 December, 2019.**



**Figure 10. Percentage roadkill among roadside transects for arthropod taxa in Asia: (A) forest and suburb/scrubland roads, southern Karnataka, India, Aug-Nov 2005 (Rao and Girish 2007); (B) forest roads, Kalakad Mundanthurai Tiger Reserve, India, Oct 2013-Sep 2014 (Sathish-Narayanan et al. 2016) (also Fig. 11C); (C) Anamalai Tiger Reserve, Western Ghats, India, Jun-Sep 2011/Oct-Dec 2012 (Jegnathan et al. 2018); routes 276 (D) and 453 (E), forest, Lake Shikotsu, Hokkaido, Japan, Jun-Sep 2007 (Yamada et al. 2010). Images of common Asian migratory species (iNaturalist 2020e, Kunte et al. 2020).**





**Figure 11. Percentage roadkill among roadside transects for Lepidoptera taxa in India and Nepal: (A) Highway NH212, agricultural area, Pookode to Vythiri, Kerala, India, 29 Oct, 2013 (Roshnath and Cyriac 2013); (B) SH-164, forest, Moongilpallam and Mangarai, Tamil Nadu, India, 28/31 May, 2013 (Sony and Arun 2015); (C) forest roads, Kalakad Mundanthur Tiger Reserve, India, Oct 2013-Sep 2014 (Sathish-Narayanan et al. 2016); (D) Mahendra Highway AH-2, forest, Devdaha Municipality, Rupandehi District, Nepal, Sep-Nov, 2017 (Gaudel et al. 2020); (E) Highway SH151, forest, Solapur to Nannaj, Maharashtra, India, 11 Sep 2007 (Karve 2008); (F) varying roads, Nilgiri Biosphere Reserve, India, Jan-Dec 2010 (Vadivalganan et al. 2012). Images of common Asian migratory butterflies (Kunte et al. 2020, Naturalist 2020e).**

## References

- Alabama Butterfly Atlas. 2020. *Explore Alabama's Butterflies* [species search]. Accessed at: <https://alabama.butterflyatlas.usf.edu/>
- Arbogast, R.T. 1966. Migration of *Agraulis vanillae* (Lepidoptera, Nymphalidae) in Florida. *The Florida Entomologist*, 49(3): 141-145.
- Baker, R.R. 1969. The evolution of the migratory habit in butterflies. *The Journal of Animal Ecology*, 38(3): 703-746.
- Baxter-Gilbert, J.H., Riley, J.L., Neufeld, C.J., Litzgus, J.D., and Lesbarrères, D. 2015. Road mortality potentially responsible for billions of pollinating insect deaths annually. *Journal of Insect Conservation*, 19(5): 1029–1035.
- Bharos, A.M.K. 2000. Large scale emergence and migration of the Common Emigrant butterflies *Catopsilia pomona* (Family: Pieridae). *Journal of the Bombay Natural History Society*, 97(2): 301.
- Bhaumik, V. and Kunte, K. 2018. Female butterflies modulate investment in reproduction and flight in response to monsoon-driven migrations. *Oikos*, 127(2): 285-296.
- Blumenthal, R. 2006. In Texas, conditions lead to a rabble of butterflies. *New York Times* 27 July, 2006. Accessed at: <https://www.nytimes.com/2006/07/27/us/27butterflies.html>
- Dykman, S. 2019. Once a butterbiker, always a butterbiker. *Beyond a Book* blog, 8 December, 2019. Accessed at: <http://www.beyondabook.org/butterbike-blog-1/2019/12/6/once-a-butterbiker-always-a-butterbiker>
- Einem, G.E. 2003. Fall migration of queens, *Danaus gilippus strigosus* Bates, in Mexico and Texas. *News of the Lepidopterist's Society*, 45(2): 39, 47. Accessed at: <http://citeseerx.ist.psu.edu/viewdoc/download?doi=10.1.1.695.410&rep=rep1&type=pdf>
- Fisher, K.J. 1945, December. Two species of *Colias* migrating in central USA (Lep. Rhopalocera). *Proceedings of the Royal Entomological Society of London. Series A, General Entomology*, 20(10-12): 107-109.
- Gaudel, P., Paudel, M., Gaudel, P., Giri, B.R. and Shrestha, B.R. 2020. Mortality census of the road-killed butterflies in Mahendra highway, Nepal. *Journal of Insect Biodiversity and Systematics*, 6(1): 87-99.
- Gilbert, L.E. 1985. Ecological factors which influence migratory behavior in two butterflies of the semi-arid shrublands of south Texas. In: Rankin, M.A.R. (ed.), *Contributions in Marine Science: Migration: Mechanisms and Adaptive Significance*, University of

Texas Marine Science Institute, Port Aransas, Texas, Supplemental Vol. 27: 724-747.  
Accessed at: <http://www.texasento.net/Gilbert1985.pdf>

- Glassberg, J. 1999. *Butterflies through Binoculars: The East*. Oxford University Press, New York, New York. Accessed at:  
[https://www.google.com/books/edition/\\_/vxJexOBOj5QC?hl=en&gbpv=1&bsq=Queen](https://www.google.com/books/edition/_/vxJexOBOj5QC?hl=en&gbpv=1&bsq=Queen)
- Halbritter, D.A., Daniels, J.C., Whitaker, D.C. and Huang, L. 2015. Reducing mowing frequency increases floral resource and butterfly (Lepidoptera: Hesperioidea and Papilionoidea) abundance in managed roadside margins. *Florida Entomologist*, 98(4):1081-1092.
- Her, K. 2008. Ensuring a Safe Journey. *Taiwan Today, Taiwan Review*, 1 August, 2008.  
Accessed at: <http://taiwantoday.tw/news.php?post=23836&unit=14,29,34,45>
- iNaturalist. 2020a. *Observations*. Accessed at: <https://www.inaturalist.org/observations/>  
Observation numbers to append to URL: monarch – 21358663, gulf fritillary- 49150, goatweed butterfly - 5666603, queen – 1644480, elada checkerspot – 195679, red admiral – 197336, question mark – 197328, orange Sulphur – 722604, clouded Sulphur – 32776145, large white – 39201480, cabbage white – 26344682, green-veined white - 33975261, small tortoiseshell - 368645
- iNaturalist. 2020b. *Observations- Roadkills of Texas - American Snout*. Accessed at:  
[https://www.inaturalist.org/observations?captive=any&place\\_id=any&project\\_id=17477&verifiable=any&view=&taxon\\_id=58561&page=](https://www.inaturalist.org/observations?captive=any&place_id=any&project_id=17477&verifiable=any&view=&taxon_id=58561&page=)
- iNaturalist. 2020c. *Observations – Roadkills of Texas – Common Buckeye*. Accessed at:  
[https://www.inaturalist.org/observations?captive=any&place\\_id=any&project\\_id=17477&verifiable=any&view=&iconic\\_taxa=Insecta&taxon\\_id=48505&page=](https://www.inaturalist.org/observations?captive=any&place_id=any&project_id=17477&verifiable=any&view=&iconic_taxa=Insecta&taxon_id=48505&page=)
- iNaturalist. 2020d. *Observations – Roadkills of Texas – Insects*. Accessed at:  
[https://www.inaturalist.org/observations?captive=any&place\\_id=any&project\\_id=17477&verifiable=any&view=species&iconic\\_taxa=Insecta](https://www.inaturalist.org/observations?captive=any&place_id=any&project_id=17477&verifiable=any&view=species&iconic_taxa=Insecta)
- iNaturalist. 2020e. *Observations*. Accessed at: <https://www.inaturalist.org/observations/>  
Observation numbers to append to URL: lemon emigrant – 29552610, wandering glider – 20248118 (credit Lenny Worthington), double-branded crow- 29454384, dark blue tiger – 34627470, lime swallowtail – 27876700, common crow – 30749150, blue tiger – 28989296
- Jeganathan, P., Mudappa, D., Kumar, A. and Raman, T.S. 2018. Seasonal variation in wildlife roadkills in plantations and tropical rainforest in the Anamalai Hills, Western Ghats, India. *Current Science*, 114: 619-626.



- Kantola, T., Tracy, J.L., Baum, K.A., Quinn, M.A. and Coulson, R.N. 2019. Spatial risk assessment of eastern monarch butterfly road mortality during autumn migration within the southern corridor. *Biological Conservation*, 231:150-160.
- Karve, P. 2008. Butterfly roadkills: Nannaj Wildlife Sanctuary, Solapur, Maharashtra. *My Butterfly* blog, 10 April, 2008. Accessed at: <http://karvepinakin.blogspot.com/2008/04/butterfly-road-kills.html>
- Keilsohn, W., Narango, D.L. and Tallamy, D.W. 2018. Roadside habitat impacts insect traffic mortality. *Journal of Insect Conservation*, 22(2): 183-188.
- Kunte, K. 2005. Species composition, sex-ratios and movement patterns in Danaine butterfly migration s in southern India I. *Journal of the Bombay Natural History Society*, 102(3): 280-286. Accessed at: <http://biodiversitylab.ncbs.res.in/sites/default/files/images/website/KunteDanaineMigration05.pdf>
- Kunte, K., Sondhi, S., and Roy, P. 2020. *Butterflies of India*, v. 2.76. Indian Foundation for Butterflies. [*Eurema hecabe* and *Catopsilia pyranthe*]. Accessed at: <https://www.ifoundbutterflies.org>
- Martin, A.E., Graham, S.L., Henry, M., Pervin, E. and Fahrig, L. 2018. Flying insect abundance declines with increasing road traffic. *Insect Conservation and Diversity*, 11(6): 608-613.
- McKenna, D.D., McKenna, K.M., Malcom, S.B., and Berenbaum, M.R. 2001. Mortality of Lepidoptera along roadways in central Illinois. *Journal of Lepidopterists' Society*, 55 (2): 63-68.
- Monarch Watch. 2020. Monarch Population Status. *Monarch Watch Blog*, 13 March 2020. Accessed at: <https://monarchwatch.org/blog/2020/03/13/monarch-population-status-42/>
- Mora Alvarez, B.X., Carrera-Treviño, R., and Hobson, K.A. 2019. Mortality of monarch butterflies (*Danaus plexippus*) at two highway crossing "hotspots" during autumn migration in Northeast Mexico. *Frontiers in Ecology and Evolution*, 7: 273.
- Munguira, M.L. and Thomas, J.A. 1992. Use of road verges by butterfly and burnet populations, and the effect of roads on adult dispersal and mortality. *Journal of Applied Ecology*, 29(2): 316-329.
- Muñoz, P.T., Torres, F.P. and Megías, A.G. 2015. Effects of roads on insects: a review. *Biodiversity and Conservation*, 24(3): 659-682.
- Nielsen, J.E. 2015. A range extension for *Eurema alitha* (C. & R. Felder) (Lepidoptera: Pieridae) in Australia, with notes on the migratory behaviour of *Eurema* species in South-east Queensland. *Australian Entomologist*, 42(1): 15-18.

- Patil, M.D. 2016. Natural history observations on mass congregation and diapause behaviour of pre-migratory roosting Danainae (Lepidoptera: Nymphalidae) from Sahyadri Mountains, India. *South Asian Journal Life Sciences*, 4(1): 25-31.
- Patil, V.K., Patil, M.D. and Narkhede, S.S. 2014. Danainae congregation in the Konkan region of Maharashtra, India. *Current Science*, 106(4): 514-515.
- Ramesh, T., Hussain, K.J., Satpathy, K.K. and Selvanayagam, M. 2013. Seasonal population dynamics and migration of butterflies in coastal plains of Kalpakkam, southern India. In: Gupta, V.K. and Verma, A.K. (eds.) *Animal Diversity Natural History and Conservation*, Vol. 3, M/S Daya Publishing House, New Delhi, India, pp. 37-54.
- Rao, R.S.P. and Girish, M.S. 2007. Road kills: Assessing insect casualties using flagship taxon. *Current Science*, 92(6): 830-837.
- Roer, H. 1991. On the direction of migration and flight capacity of the nymphalids *Inachis io*, *Aglais urticae* and *Vanessa atalanta* in the central European area after recapturing marked butterflies. *Entomologische Berichten*, 51(12): 179-182.
- Roshnath, R. and Cyriac, V.P. 2013. Way Back Home-Butterfly Roadkills. *Zoo's Print*, 28(12): 18-20. Accessed at: <http://www.zoosprint.zooreach.org/index.php/zp/article/download/1339/1237>
- Samways, M.J. 2019. Addressing global insect meltdown. *The Ecological Citizen*, 3(Suppl A): 3-6.
- Santhosh, S., and Basavarajappa, S. 2014. Road mortality of migrant butterflies [Nymphalidae: Danaiane] at National Highway-209 in Chamarajanagar District of Karnataka, India. *Indian Journal of Applied Research*, 4: 553-557. Accessed at: [https://www.worldwidejournals.com/indian-journal-of-applied-research-\(IJAR\)/fileview.php?val=September 2014 1492849834 166.pdf](https://www.worldwidejournals.com/indian-journal-of-applied-research-(IJAR)/fileview.php?val=September 2014 1492849834 166.pdf)
- Santhosh, S. and Basavarajappa, S. 2017. Migratory behaviour of two butterfly species (Lepidoptera: Nymphalidae) amidst agriculture ecosystems of South-Western Karnataka, India. *Journal of Entomology and Zoological Studies*, 5(1): 758-765. Accessed at: [https://www.researchgate.net/profile/Basavarajappa\\_Sekarappa/publication/316826047\\_Migratory\\_behaviour\\_of\\_two\\_butterfly\\_species\\_Lepidoptera\\_Nymphalidae\\_amidst\\_agriculture\\_ecosystems\\_of\\_South-Western\\_Karnataka\\_India/links/5912bd674585152e1998a4c0/Migratory-behaviour-of-two-butterfly-species-Lepidoptera-Nymphalidae-amidst-agriculture-ecosystems-of-South-Western-Karnataka-India.pdf?origin=figuresDialog](https://www.researchgate.net/profile/Basavarajappa_Sekarappa/publication/316826047_Migratory_behaviour_of_two_butterfly_species_Lepidoptera_Nymphalidae_amidst_agriculture_ecosystems_of_South-Western_Karnataka_India/links/5912bd674585152e1998a4c0/Migratory-behaviour-of-two-butterfly-species-Lepidoptera-Nymphalidae-amidst-agriculture-ecosystems-of-South-Western-Karnataka-India.pdf?origin=figuresDialog)
- Saraf, K.K. and Jadesh, M. 2017. A preliminary study on road killed butterflies at National Highway-50, Kalaburagi district, Karnataka, India. *International Journal of Entomology Research*, 2(1): 42-50.

- Sathish-Narayanan, S., Pradeepa, V., Venkatesh, A. and Kanchana, R. 2016. Effect of road kills on wildlife populations in Kalakad Mundanthurai Tiger Reserve. *International Journal of Advanced Research*, 4(3): 193-204.
- Seibert, H.C. and Conover, J.H. 1991. Mortality of vertebrates and invertebrates on an Athens County, Ohio, Highway. *The Ohio Journal of Science*, 91(4): 163-166.
- Skórka, P. 2016. The detectability and persistence of road-killed butterflies: an experimental study. *Biological Conservation*, 200: 36-43.
- Skórka, P., Lenda, M., Moroń, D., Kalarus, K. and Tryjanowski, P. 2013. Factors affecting road mortality and the suitability of road verges for butterflies. *Biological Conservation*, 159: 148-157.
- Skórka, P., Lenda, M. and Moroń, D. 2018. Roads affect the spatial structure of butterfly communities in grassland patches. *PeerJ*, 6: e5413.
- Schweitzer, D.F. 2006. The winter ecology of *Colias eurytheme* Boisduval (Pieridae) and its dependence on exotic legumes in Southern New Jersey. *Journal of Lepidopterists' Society*, 60(1): 51-60.
- Sony, R.K. and Arun, P.R. 2015. A case study of butterfly road kills from Anaikatty Hills, Western Ghats, Tamil Nadu, India. *Journal of Threatened Taxa*, 7(14): 8154-8158. Accessed at: <https://ww.w.zooreach.org/index.php/JoTT/article/download/1743/3468>
- Spieth, H.R. and Cordes, R. 2012. Geographic comparison of seasonal migration events of the large white butterfly, *Pieris brassicae*. *Ecological Entomology*, 37(6): 439-445.
- Taiwan Environmental Protection Administration. 2010. Environmental inspection: highways yield to flyways – EPA takes up butterfly conservation. *Environmental Policy Monthly* (Environmental Protection Administration, Republic of China [Taiwan]). 13. pp. 9–10. Accessed at: <https://www.epa.gov.tw/cpDownloadCtl.asp?id=61993>
- Taiwan Area National Freeway Bureau. 2015. *National Road No. 3 Nanyun Interchange Project Butterfly Monitoring Survey Report*. (In Chinese). Accessed at: <https://www.freeway.gov.tw/UserFiles/File/Widening/HistoryArea/GroupAndCulture/2-5-1-2ButterflySurveyReport.pdf>
- Thogmartin, W.E., Diffendorfer, J.E., López-Hoffman, L., Oberhauser, K., Pleasants, J., Semmens, B.X., Semmens, D., Taylor, O.R. and Wiederholt, R. 2017. Density estimates of monarch butterflies overwintering in central Mexico. *PeerJ*, 5: e3221.
- Tracy, J.L., Kantola, T., Baum, K.A. and Coulson, R.N. 2019. Modeling fall migration pathways and spatially identifying potential migratory hazards for the eastern monarch butterfly. *Landscape Ecology*, 34(2): 443-458.

- Tracy J.L., and Coulson R.N. 2019. *Eastern Monarch Butterfly Fall Migratory Roadkill Distribution and Hotspot Regions within the Coastal and Central Migratory Funnels of Texas*. Texas A&M Department of Entomology/Texas Transportation Institute Project Final Report. TxDOT Environmental Affairs Division, Austin, Texas. 32 pp. Accessed at: [https://www.dropbox.com/s/an9wuzkyr54xdb0/TTI\\_TAMU%20Texas%20Monarch%20Roadkill%20Fall%202018%20Report.docx?dl=0](https://www.dropbox.com/s/an9wuzkyr54xdb0/TTI_TAMU%20Texas%20Monarch%20Roadkill%20Fall%202018%20Report.docx?dl=0)
- Troast, D., Suhling, F., Jinguji, H., Sahlén, G. and Ware, J. 2016. A global population genetic study of *Pantala flavescens*. *PloS one*, 11(3): e0148949.
- Vadivalagan, C., Gunasekaran, C. and Salahudeen, I. 2012. Molecular phylogeny of recurrent road killed butterflies in Nilgiri biosphere reserve, India, using CO1 gene marker. *African Journal Biotechnology*, 11(79): 14433-14439.
- Wang, H.Y. and Emmel, T.C. 1990. Migration and overwintering aggregations of nine danaine butterfly species in Taiwan (Nymphalidae). *Journal of Lepidopterists' Society*, 44: 216-228.
- Walker, T.J. 1978. Migration and re-migration of butterflies through north peninsular Florida: quantification with Malaise traps. *Journal of the Lepidopterists' Society*, 32(3): 178-190.
- Walker, T.J. 1991. Butterfly migration from and to peninsular Florida. *Ecological Entomology*, 16(2): 241-252.
- Walker, T.J. 2001. Butterfly migrations in Florida: seasonal patterns and long-term changes. *Environmental Entomology*, 30(6): 1052-1060.
- Wikelski, M., Moskowitz, D., Adelman, J.S., Cochran, J., Wilcove, D.S. and May, M.L. 2006. Simple rules guide dragonfly migration. *Biology Letters*, 2(3): 325-329.
- Williams, C.B. 1927. A study of butterfly migration in south India and Ceylon, based largely on records by Messrs. J. Evershed, EE Green, JCF Fryer and W. Ormiston. *Transactions of the Royal Entomological Society of London*, 75(1): 1-33.
- Williams, C.B. 1930. *The Migration of Butterflies*. Oliver & Boyd, London, United Kingdom.
- Williams, C.B., 1933. Further collected records relating to insect migration. *Transactions of the Royal Entomological Society of London*, 81(1): 103-116.
- Yamada, Y., Sasaki, H. and Harauchi, Y. 2010. Composition of road-killed insects on coastal roads around Lake Shikotsu in Hokkaido, Japan. *Journal Rakuno Gakuen University*, 34(2): 177-184.



Yata, O. 1995. A revision of the Old World species of the genus *Eurema* Hübner (Lepidoptera, Pieridae): Part V. Description of the *hecabe* group (part). *Bulletin Kitakyushu Museum Natural History*, 14: 1-54.

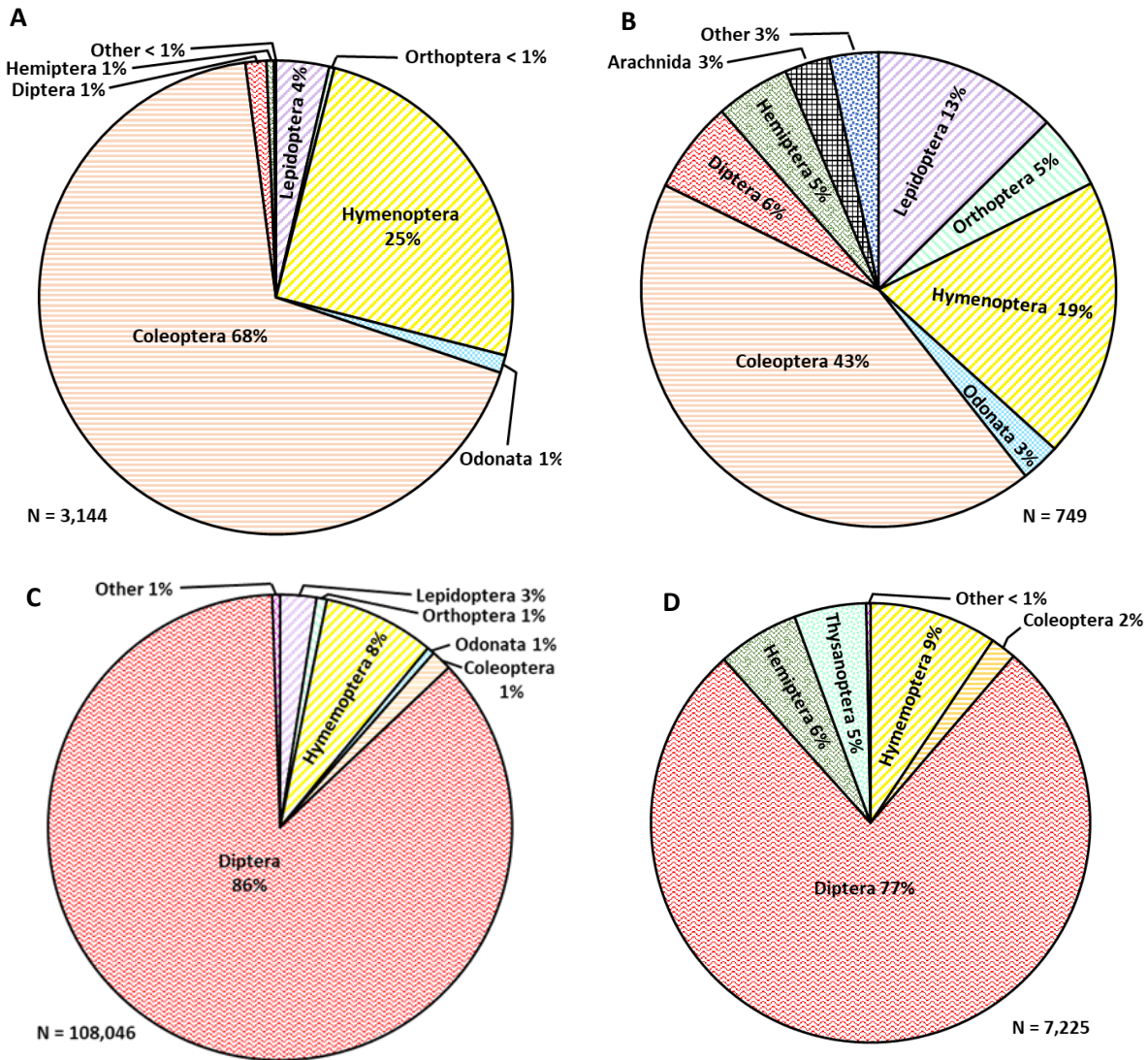
## Appendix

Roadkill on the south side of the roadway was lower than on the north side in transects for all arthropod taxa (Table A.1). Where roadkill counts were only made on the north side of the roadway ( $n = 61$  thinned transects), we estimated a lower count for the south side based on the lower percentage of 43% for monarchs, including data from previous studies (Kantola et al. 2019, Tracy and Coulson 2019). Lower percentages of 18% and 67% on the south side compared to the counted north side of the roadway were used for all other Lepidoptera and non-Lepidoptera arthropods, respectively (Table A.1). When counts were only made on the south side of the roadway ( $n = 18$  thinned transects), a conservative estimate of the same count was assigned to the north side of the roadway. When only the west or east side of road transect was counted in this study ( $n = 11$  and 30 thinned transects, respectively), the west side transect was estimated as the lower count side in the same manner as a south side transect, following the findings of Tracy and Coulson (2019) for monarchs (Table A.1). Texas fall monarch roadkill area estimates for 2016-2017 (Kantola et al. 2019) and 2018 (Tracy and Coulson 2019) were recalculated using the same methods in this study for comparative purposes, using a single average roadkill rate over all road types and omitting additional hotspot zone estimates.

**Table A.1. Arthropod roadkill totals for 100 m transects on different sides of the roadway within Texas central and coastal monarch migratory funnels from various studies.**

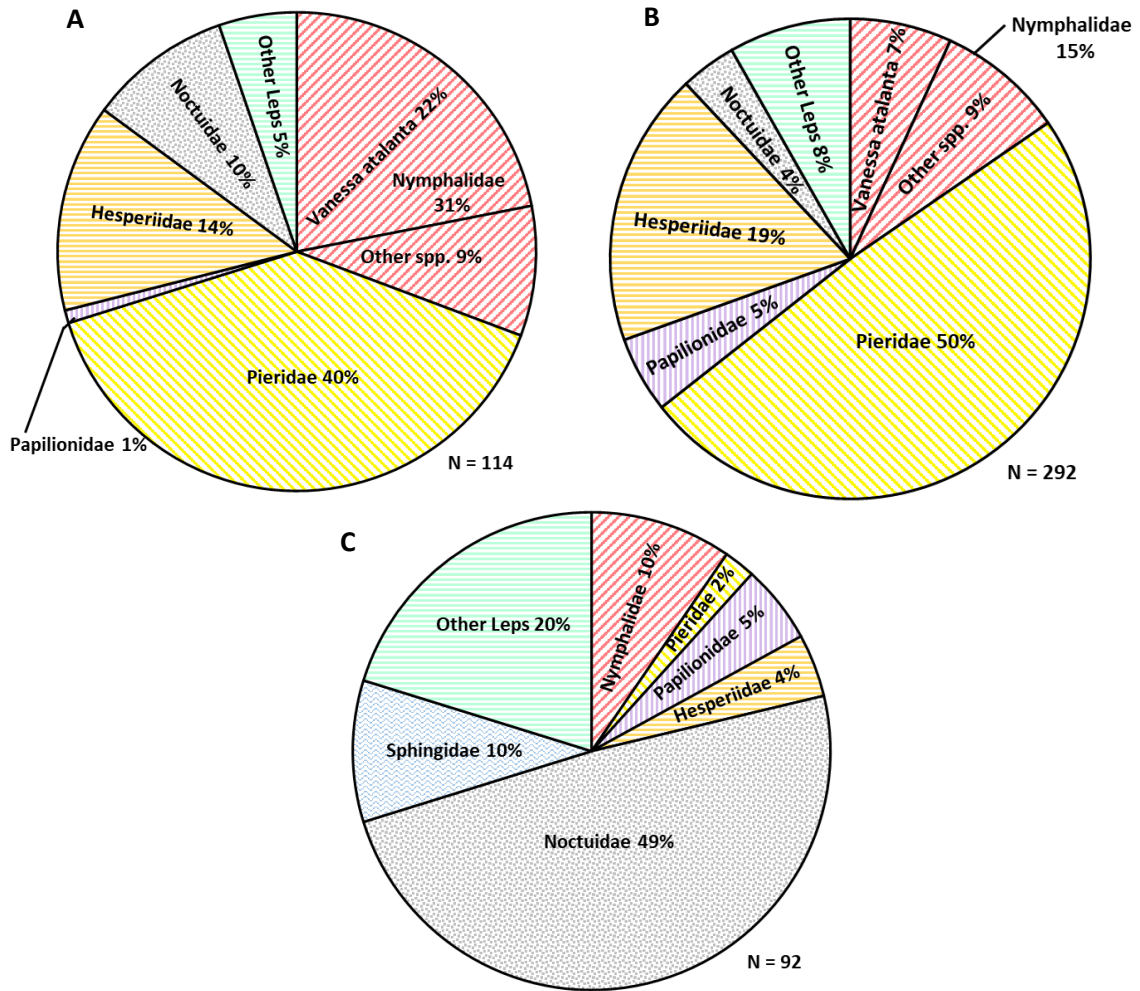
Taxa	Roadkill Counts Summed from Transects		
	North Side	South Side	Percent South of North Side
<i>This Study</i> (n = 38 transects <sup>a</sup> )			
<i>Lepidoptera</i>			
Monarch ( <i>Danaus plexippus</i> )	80	29	36%
Sulphurs ( <i>Colias</i> spp.)	43	9	21%
Gulf Fritillary ( <i>Agraulis vanillae</i> )	16	2	13%
Other Lepidoptera (excluding above taxa)	13	2	15%
Non-Monarch Lepidoptera	72	13	18%
<i>Arthropods Excluding Lepidoptera</i>	12	8	67%
<i>All Arthropods</i>	164	50	30%
<i>Monarch - Previous Studies</i>			
Central Funnel Fall 2016-2017 (Kantola et al. 2019) (n = 12 transects)	143	65	45%
Central and Coastal funnels Fall 2018 (Tracy and Coulson 2019) (n = 25 transects)	155	62	40%
<i>Monarch - Combined Studies</i>	433	188	44%
<i>Monarch - Previous Study</i>			
Central and Coastal funnels Fall 2018 (Tracy and Coulson 2019) (n =24 transects)	31	56	55%

<sup>a</sup>Transects not spatially thinned (includes six additional monarch roadkill hotspot transects).



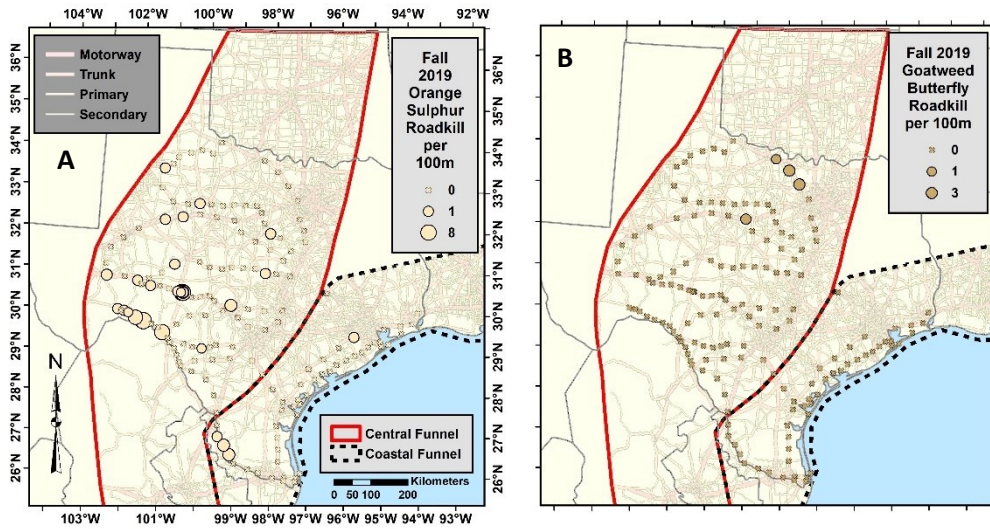
**Figure A.1. Percentage roadkill among roadside transects (A-C) or vehicle mounted sticky traps (D) for Arthropod taxa in North America: (A) lawn and (B) woodland roads in Delaware, Maryland, and Pennsylvania, Jun-Jul, 2015 (Keilsohn et al. 2018); (C) highway 69/100, forests/wetlands, Georgian Bay, Lake Huron, Ontario, Canada, May-Aug, 2013 (Baxter-Gilbert et al. 2015); (D) variety of rural roads, southeastern Ontario, Canada, Jun-Sep 2014 (Martin et al. 2018).**





**Figure A.2. Percentage roadkill among roadside transects for Lepidoptera taxa in North America: (A) lawn, (B) meadow, and (C) woodland roads in Delaware, Maryland, and Pennsylvania, Jun-Jul, 2015 (Keilsohn et al. 2018).**





**Figure A.4. Spatial distribution of roadkill per 100 m x 1 m transect (unthinned) for various lepidoptera taxa during the fall of 2019 within Texas monarch migratory funnels: (A) orange sulphur; (B) goatweed butterfly.**

## CHAPTER 3. SPRING 2020 MONARCH AND ARTHROPOD ROADKILL AND ROADSIDE MILKWEEDS AND NECTAR PLANTS

### Summary

Monarch roadkill in the monarch migratory Central Funnel and eastwards in Texas for spring 2020 was estimated at 190,240. This estimate is about 42% the 448,373 estimated Texas roadkill in the fall of 2019, and much lower than the 3.5 million estimated Texas roadkill for fall 2018. Negligible monarch roadkill was estimated in the only other spring roadkill survey in Texas in 2017. For all arthropod species in the spring of 2020, roadkill in the Texas Central Funnel and eastwards was estimated at about 14.5 million, much higher than the 1.9 million estimated for arthropods in the fall 2019 for the combined Central and Coastal funnels. Pollinators comprised 75% of the spring roadkill, including Lepidoptera (53%) and Hymenoptera (18%). Lepidoptera comprised a lower proportion of spring roadkill than seen with the 69% and 86% Lepidoptera roadkill for the fall 2019 Central and Coastal funnels, respectively. Lepidoptera roadkill was not significantly correlated with milkweed density or percent cover of monarch-preferred nectar plants. Monarchs composed only three percent of the spring Lepidoptera roadkill compared to 33% reported for fall 2019. Orange sulphur, painted lady, and buckeye butterflies comprised the majority of the spring Lepidoptera roadkill. Green antelopehorn comprised 56% of the spring 2020 milkweed roadside plants counted, and antelopehorns dominated 63% of the milkweed stems counted.. Several roadside milkweed hotspots ranging from 40 to 195 plants per 100 meters were found for the four major species, green antelopehorn, antelopehorns, zizotes milkweed, and broadleaf milkweed.. An estimated 22,177 ha of preferred monarch spring nectar plants occurred along major roadways of the study area, being recorded from 70% of 106 transects. Dominant nectar plants included widely distributed Texas vervain and regional stands of Lance leaved coreopsis and Engelmann daisy. Milkweeds were the only very high value monarch spring roadside nectar plants found. Fourteen percent (12) of the 69 transects with milkweed had from one to five monarch larvae, mostly on green antelopehorn and antelopehorns milkweeds. These data can inform regional planning of spring monarch roadside milkweed and nectar plant conservation activities as compensatory mitigation for monarch road mortality during the fall migration.

### Methods

Roadkill observations were made by a two-person team following the same protocol as Kantola et al. (2019), employing 100 x 1 meter *dispersed* transects that were spaced about every 80 km (50 mi), instead of 20-30 km, in order to cover a wider area during the spring migration. The spacing did not count km through urban areas. Transects were established by roadside milkweed stands, where feasible, in order to obtain information



on monarch larval abundance on roadside milkweeds and relative abundance of roadside milkweed species. The person not driving was the designated spotter for locating potential transect sites among roadside milkweed stands. A dispersed transect stop was required if not finding milkweed by 100 km (62 mi), to ensure transects were made at least every 100 km. Also, one or two extra *adventitious transects* were established per day between the 60-100 km dispersed transects, as time allowed, when spotting an unusually large milkweed patch or less common species of milkweed. The location of each transect was recorded as either the North, South, East, or West side of the road, depending on the orientation of the road. Around once a day, as time allowed, an additional *across road transect* was established on the opposite side of the road of a milkweed stand in order to look for patterns across roadway sides. Roadkill transects were counted over the four major Open Street Map road classes (Geofabrik 2017), which encompass the four main Federal Highway Administration (FHWA) road classes (USDOT-FHWA 2013, 2020), throughout the Texas portions of the monarch migratory Central Funnel and eastwards in Texas (Fig. 1, Table A1). Observations were made over trips every other week from 30 March to 28 May.

Each roadkill transect was associated with an overlapping 100 x 5 meter monarch/milkweed/nectar plant transect and a centrally located 5 x 50 m plant percent cover transect. The total number of milkweed plants of all species were counted in the 100 x 5 m transect, and at least six milkweeds, if available, were examined for monarch larvae and their number of stems and length of maximum stem was recorded. Within the central 5 x 50 m percent cover transect, percent cover was visually estimated for all plant species and ground covers (e.g., "bare ground") to within ca. 1%, including nectar plants that are preferred for nectar by monarchs. Percent cover values recorded as "<1%", and ">1%" were assigned values of "0.4%" and "1.4%" for analysis, respectively. Plants identified as monarch preferred nectar sources were primarily determined from a large regional list compiled by the USDA NRCS (2018) and supplemented with additional regional sources (Pollinator Partnership 2013, Ajilvsgi 2013). Nectar plants that were closely related congeners of monarch preferred nectar plant species in our roadside transects (e.g., *Cirsium* spp., *Centaurea* spp., *Verbena* spp., and *Solidago* spp.) were also regarded as preferred species (c.f., Ajilvsgi 2013). The presence and activity of live butterflies were also recorded within the transect.

Counts of roadkill and area of monarch-preferred nectar plants were extrapolated over total lengths of major OSM roadways (fclasses 1-4) in the study area. Transect placement was not random with respect to milkweeds for which searches were made every 100 km (100,000 m) units of roadway. Therefore, milkweed data was only used for relative abundance comparisons and extrapolations over roadways were not made.

Field assistants worked in pairs and wore class III safety vests, hard hats with reflective tape, and steel toed boots (Fig. 2A) for recording observations (Fig. 2B-F). Potential

differences in densities of arthropod roadkill and milkweed plants per 100 meters and nectar plant percent cover in 50 m x 5 m transects were tested for differences among OSM road classes using the non-parametric Kruskal-Wallis test. Roadkill estimates, milkweed numbers, and the area of monarch preferred nectar plants were extrapolated across the Texas Central Funnel and eastwards by multiplying numbers per km or areas from dispersed random transects with lengths of roadway or roadside area (e.g., McKenna et al. 2001, Kantola et al. 2019). Pairwise correlations by locations for roadkill per 100 m among Lepidoptera, and Lepidoptera with milkweed plant counts per 100 m and nectar plant percent cover per 50m x 5 m plot were tested among selected arthropod taxa using the Spearman rank order correlation ( $r_s$ ), with Holm's correction for multiple comparisons with the r psych package (for Excel spreadsheets and Google Earth kml files of spring 2020 roadkill and roadside data and Excel spreadsheets with charts, see <https://drive.google.com/drive/folders/1n812k0dsXlzvETuHAGSu99uulPD2Llm7?usp=sharing> )

## Results and Discussion

### *Arthropod Roadkill*

Estimated arthropod roadkill per transect was not significantly different among the four road classes examined in this study (Table 1). Consequently, data are pooled among highway types for comparisons and for estimating total roadkill. Estimated monarch roadkill of 190,240 in the spring (Table 2) represents about 42% of the estimated 448,373 monarch roadkill for the fall of 2019 in the Texas Central and Coastal funnels (Tracy et al. 2020a), and much less than the 3.5 million monarch roadkill similarly estimated for fall of 2018 (Tracy and Coulson 2019). Estimated total arthropod roadkill in the spring of 2020 for the Texas Central Funnel/East Texas region was 14.5 million (Table 2), which is much higher than the combined totals of 1.9 million from the Texas Central and Coastal funnels in the fall of 2019 (Tracy et al. 2020a). Texas Lepidoptera roadkill was estimated at 7.7 million for the spring (Table 2), compared to 1.4 million in the fall.

Monarchs comprised only 3% of the spring 2020 Lepidoptera roadkill (Table 2), compared to 32% of the fall 2019 roadkill (weighted average from Central and Coastal funnels; Tracy et al. 2020b). The 3% value for monarch spring roadkill is similar to lower percentages of Lepidoptera roadkill comprised of monarchs during the fall in Illinois (5%; McKenna et al. 2001) and from spring through fall in Florida (3%; Halbritter et al. 2015) (see Fig. 4 of Part III Chapter 2).

Lepidoptera made up about 53% of spring 2020 arthropod roadkill, compared to 69% in the fall of 2019 Central Funnel (Fig. 3A-B). The 53% spring Lepidoptera roadkill figure is a little larger than the 42% proportion for Lepidoptera roadkill in Belgium (Vercayie and Lambrechts 2017) (Fig. 3C), but much higher than the proportion of Lepidoptera roadkill

among arthropods found in several other studies in North America and Europe (Part III Chapter 2). Spring Lepidoptera roadkill counts per transect were much higher at 10.05 per 100 m (Table 2) than the 2.07 per 100 m observed in fall 2019 for the Central Funnel (Part III Chapter 2). Much greater proportions of Coleoptera and Hymenoptera with lower proportions of Orthoptera were found in spring roadkill compared to fall roadkill (Table 2, Fig. 3A).

Lepidoptera roadkill in the spring was dominated by Pieridae, especially orange sulphurs (Table 2, Figs. 3D, 4A), compared to the dominance by Nymphalidae, particularly monarchs, in the fall of 2019 (Part III Chapter 2). A greater number of species appeared in spring roadkill than in fall roadkill, particularly dominated by Nymphalidae, such as painted lady, buckeyes and variegated fritillary (Table 2, Figs. 3D, 4). Eight species of Pierids were found in spring roadkill, of which six were not seen in fall roadkill, including lyside sulphur and southern dogface (Fig. 4F-G). Greater numbers of Papilionidae and Lycaenidae roadkill were also seen in the spring. The high proportion of Lepidoptera roadkill comprised of Nymphalidae and Pieridae (Fig. 3D) is similar to what we observed in the fall of 2019 (Fig. 3E) and in some other studies in Europe and Asia (Part III Chapter 2). Barrows (2018) found an unusually high proportion of Nymphalidae (96%), roadkill along a gravel road in Kansas consisting mainly of male hackberry emperor butterflies that were part of an aggregation of thousands feeding on cattle dung (Fig. 3F).

Several large hotspots of Arthropod roadkill were found (Fig. 5), many of which were Lepidoptera roadkill hotspots (Fig. 5B), with a few prominent hotspots for Coleoptera and Hymenoptera (Fig. 5C-D). Lepidoptera roadkill was generally widely distributed across the Texas Central Funnel/East Texas region (Figs. 5B). The major Lepidoptera roadkill hotspots were located in Central and North Central Texas and comprised mainly of orange sulphur, painted lady, buckeye and variegated fritillary butterflies (Fig. 6A-D). Roadkill of most individual Lepidoptera species, including monarchs, was also widely distributed (Figs 6, A1), with the exception of lyside sulphur roadkill, which was restricted to the western portion of South Texas (Fig. 6E) where it is more commonly found (iNaturalist 2020). A maximum of four roadkill monarchs per transect were found in the spring, with no prominent hotspots (Fig. 6F). The two largest Lepidoptera roadkill hotspots were found northeast of Ranger (302 roadkill) (Fig. 7A), dominated by orange sulphur, buckeye, and painted lady butterflies, and south of Johnson City (114 roadkill) dominated by painted lady butterflies and including two monarchs (Fig. 7B). These two hotspots were not associated with high nectar plant densities from the percent cover transects, but the south of Johnson City roadkill was associated with an antelopehorns hotspot outside the percent cover plot (Fig. 12B) (for analyses showing lack of correlations of roadkill with milkweeds and percent cover of nectar plants, see Roadside Milkweeds and Roadside Monarch-Preferred Nectar Plants below).

The occurrence of monarch roadkill was significantly moderately correlated with roadkill of the four most common roadkill lepidopteran species, painted lady, buckeye, and orange sulphur, with  $r_s$  values ranging from 0.39 to 0.43 (Table 3). Overall correlation of monarch roadkill to roadkill of all other Lepidoptera was also significantly moderate, with  $r_s$  of 0.40 (Fig. 13).

The proportion of pollinator Hymenoptera roadkill in the spring (Table 2) was about double that observed in the fall, with several large roadkill hotspots in North Central and Eastern Texas (Fig. 8A). A few European honeybee roadkill hotspots were found in East Texas (Fig. 8B), and many widely distributed roadkill hotspots were found for native bees and wasps (Fig. 8C-D).

### Roadside Milkweeds

Numbers of milkweed plants per transect did not significantly differ among road classes and were pooled for comparisons and extrapolations (Table 1). Even though milkweed were searched for about every 80 km in the dispersed transects, only about 47% of the 106 dispersed random transects had milkweeds (Table 4), which is lower than the 71% of roadside plots with common milkweed (*A. syriaca*) in Iowa (Hartzler and Buhler 2000) and lower than 60% of roadside transects with milkweeds (97% *A. syriaca*) in the Upper Midwest (Kasten et al. 2016). The spring 2021 observations should include a sample of totally random milkweed-only surveys to assess the density of roadside milkweed.

The proportion of milkweed plants in all transects was dominated by green antelopehorn at 56%, followed by 30% antelopehorns, 10% zizotes milkweeds, 3% broadleaf milkweeds, and 1% other milkweeds (Table 4, Figs. 9A, 10). Other milkweeds found include green comet milkweed, whorled milkweed, longleaf milkweed, plains milkweed, Emory's milkweed, and butterflyweed (Table 4, Fig. 10). The mean stems per plant was greatest for antelopehorns (Table 4), giving it the highest proportion of 63% of all milkweed stems (Fig. 9B). There was no significant correlation between numbers of milkweed plants per transect and number of Lepidoptera roadkill (Fig. 13B).

Roadside milkweeds were found among transects throughout the survey area, but were least frequently encountered among transects in South Texas, with the largest densities in Central and Southeast Texas (Fig. 11A). The two dominant roadside milkweeds, green antelopehorn and antelopehorns, had the largest densities in the southeastern and central portions of the survey area, respectively (Fig. 11 B-C). Zizotes and broadleaf milkweeds were the most frequent roadside milkweeds in South and West Texas, respectively, being the only roadside milkweeds recorded in the extreme outer edges of these regions (Figs. 11D-E). Other species of milkweeds were scattered across roadsides of the survey area (Fig. 11F). The later season blooming broadleaf milkweed is expected to be more prominent in West Texas for the fall surveys once this data is further analyzed. Milkweeds were noted beyond the 5 m transect width away from the roadway



transect in several cases (exclusively for longleaf milkweed), and the fall 2020 and spring 2021 surveys will include separate milkweed counts along an additional inner 5 m x 100 m transect. Several hotspots of milkweed occurrence with more than 40 plants per transect were found among the top four milkweed species (Fig. 11B-E), some of which were along major US highways (Fig. 12).

### Roadside Monarch Preferred Nectar Plants

Percent cover for roadside monarch preferred nectar plant species within the 50 m x 5 m portions of transects did not significantly differ with road class (Table 1), and data were pooled across road classes for analysis (Table 2). Twenty-one species of monarch preferred April-May nectar plants were found in our primary dispersed transects, of which two were exotic (Maltese Star-thistle and Brazilian vervain) (Table 5, Fig. 14). Only the three major milkweed species (*A. viridis*, *A. asperula* ssp. *capricornu*, and *A. oenotheroides*) are rated as "Very High" value monarch nectar plants, with the rest being rated as "High" value (USDA NRCS 2018, Pollinator Partnership 2013, Ajilvsgi 2013) (Fig. 10A-C; Table 5). Three species generally comprised the greatest percentage of monarch preferred nectar plants across the transects using a variety of measures of percent frequency: Texas vervain, Lance-leaved coreopsis, and Engelmann daisy (Fig. 15). Other common nectar plants included Texas thistle and climbing milkweed vine (Fig. 15, Table 5). About 70% of the dispersed transects (74/106) had monarch preferred spring nectar plants and a total of 22,810 hectares of monarch preferred nectar plants was estimated across major highways from April-May in the Texas Central Funnel/East Texas region (Table 5). There was no significant correlation between percent cover of monarch-preferred nectar plants per transect and number of Lepidoptera roadkill (Fig. 13C).

Monarch preferred spring nectar plants were widely distributed throughout roadsides of the Texas Central Funnel/East Texas study area, with the exception of regional gaps in the northwestern area (Fig. 16A). Monarch spring nectar plant hotspots occurred in several mid-latitudes of the study area, and these were dominated by individual species, including lance leaved coreopsis (Fig. 16B), exotic Maltese star-thistle (Fig. 16C), and Engelmann daisy (Fig. 16D). Texas vervain and Texas thistle were the most widely distributed monarch nectar species in the study area (Fig. 16C, 16F). Several native species were regionally important as monarch nectar species, including lance leaved coreopsis in East Texas (Fig. 16B), Engelmann daisy to the West (Fig. 16E), lemon beebalm to the southeast and north (Fig. 17A), and climbing milkweed vine in South Texas (Fig. 17B). Immature fall monarch preferred nectar plants of annual sunflower and goldenrod were found in six transects, with hotspots for northern seaside goldenrods along the Texas coast (Fig. 18). Only three common monarch preferred nectar plants were found in fall 2019 transects: northern seaside goldenrod along the southeast coast, white heath aster (*Symphoricarpos ericoides*) in Central and Northwest Texas, and Gray Golden-aster (*Heterotheca canescens*) in the Northwest (for Spring 2020 Plant List in

transects, see excel file under

<https://drive.google.com/drive/folders/1n812k0dsXlzvETuHAGSu99uulPD2Llm7?usp=sharing> ).

### *Roadside Monarchs*

Fourteen percent (12) of the 69 transects with milkweeds (50 dispersed and 19 adventitious) had monarch larvae. Larvae were only found on three most common milkweeds of green antelopehorn, antelopehorns, and zizotes milkweed (Table 6). A total of 27 monarch larvae were found among the 12 transects with larvae, consisting of two first instars, one second instar, four third instars, seven fourth instars, and 13 fifth instars (Figs. 2E, 19; Table 6). Although the sample size of 27 larvae was small, the proportion of larvae per milkweed species (Fig. 20; Table 6) closely approximated the proportion of total plants per milkweed species found in the transects (Fig. 9A). The mean number of monarch larvae per plant for the three milkweed species with larvae ranged from 0.03 to 0.06, averaging 0.05 larvae per plant for all milkweed species (Table 6), which is greater than the 0.02 monarch larvae found per roadside milkweed plant in the Upper Midwest (Kasten et al. 2016). A fresh first-generation monarch was photographed nectaring on exotic Brazilian vervain north of Crockett, TX on 27 April (Fig. 2D). Additional spring data recorded on live monarchs and other butterflies in the transects and larval and live adult data from fall 2019 remains to be analyzed.

### *Conclusion*

An estimated 190,240 monarch roadkill occurred in the spring of 2020 throughout the Texas Central Funnel/East Texas survey area. Much higher estimated arthropod road mortality of 14.5 million was found in the spring compared to 1.9 million in the fall of 2019. Pollinators (Lepidoptera and Hymenoptera) represented 75% of the arthropod roadkill. Monarch roadkill represented only 3% of Lepidoptera roadkill in the spring of 2020 compared to 32% in the fall of 2019. We found no correlation between Lepidoptera roadkill and either numbers of milkweed per transect or percent cover of monarch-preferred nectar plants. Spring roadside milkweeds were dominated by green antelopehorn and antelopehorns, with zizotes and broadleaf milkweeds being regionally dominant. Milkweed roadside hotspots were found for all four of these species. Monarch preferred nectar plants in the spring were dominated by Texas vervain, Lance-leaved coreopsis, and Engelmann daisy, but the very high value monarch nectar species were represented only by the three major milkweeds, green antelopehorn, antelopehorns, and zizotes milkweed. Texas vervain and Texas thistle were the most widespread monarch nectar species. Several monarch nectar plants were important only in certain regions, such as lance leaved coreopsis, Engelmann daisy, and climbing milkweed vine. Information on the roadside distribution and relative abundance of milkweeds and nectar plant species is valuable in planning compensatory mitigation to benefit monarchs and other Texas pollinators.

## Tables

**Table 1. Arthropod roadkill, milkweed plants for 100 m x 5 m transects, percent cover of nectar plants for 50 m x 5 m transects, and kilometer roadway length by Open Street Map (OSM) road classes (with corresponding Federal Highway Administration, FHWA, road classifications) for April-May 2020 in Texas for monarch migratory Central Funnel and eastwards.**

Estimates per 100 m Transect (Mean $\pm$ SD) by OSM Road Classification (Major Corresponding FHWA Road Classes) <sup>a</sup>					
Unit	Motorway (60% Interstate; 26% Other Freeways and Expressways)	Trunk (83% Other Principal Arterials; 11% Minor Arterials)	Primary (43% Minor Arterials; 32% Other Principal Arterials)	Secondary (37% Major Collectors; 12% Minor Arterials;)	Overall
Arthropod Roadkill	33.05 $\pm$ 69.05 (20) <sup>a</sup>	17.71 $\pm$ 20.30 (54) <sup>a</sup>	16.60 $\pm$ 22.09 (41) <sup>a</sup>	8.15 $\pm$ 8.22 (10) <sup>a</sup>	19.03 $\pm$ 33.36 (125)
Milkweed Plants	25.45 $\pm$ 35.10 (20) <sup>a</sup>	15.65 $\pm$ 34.03 (54) <sup>a</sup>	7.59 $\pm$ 14.84 (41) <sup>a</sup>	35.3 $\pm$ 62.87 (10) <sup>a</sup>	16.14 $\pm$ 33.31 (125) <sup>b</sup>
Nectar Plant Percent Cover	2.83 $\pm$ 33.36 (19) <sup>a</sup>	2.92 $\pm$ 32.21 (40) <sup>a</sup>	1.73 $\pm$ 29.24 (9) <sup>a</sup>	3.13 $\pm$ 40.39 (53) <sup>a</sup>	2.84 $\pm$ 7.07 (125) <sup>b</sup>
Roadway Lengths (km)					
Roadways	7,372	11,358	23,340	34,026	76,096

<sup>a</sup>Means in the same row with the same letter are not significantly different ( $P < 0.05$ ; Kruskal-Wallis test) (For further details on correspondence of OSM and FHWA road classes, see Table A2).

<sup>b</sup>Overall values includes 19 non-random adventitious transects. Refer to Tables 3-4 for more representative estimates from only 106 dispersed random transects.

**Table 2. Arthropod 100 m x 1 m transect roadkill counts (includes extrapolations to uncounted sides) for various taxa in spring 2020 monarch migratory Central Funnel and eastwards.<sup>a</sup>**

Taxa/Species	Roadkill Counts (Percent of Taxa)	Roadkill per 100m x 2m Transect (Mean ± SD) (n = 124 transects)	Estimated Total Roadkill = (Estimated Roadkill per 100m x 2m) x 10 transects/km x Km Length Highways <sup>b</sup>
<i>Arthropods</i>	2,381	19.03 ± 33.36 (125)	14,483,139
Lepidoptera	1,259 (53%)	10.05 ± 26.60	7,651,179
Coleoptera	522 (22%)	4.17 ± 9.00	3,176,247
Hymenoptera	438 (18%)	3.50 ± 5.78	2,663,847
Odonata	68 (3%)	0.55 ± 1.57	416,580
Orthoptera	62 (3%)	0.50 ± 3.04	378,106
<i>Lepidoptera Taxa</i>			
<i>Nymphalidae</i>	586 (47%)	4.48 ± 14.79	3,408,918
Monarch ( <i>Danaus plexippus</i> )	32 (3%)	0.25 ± 0.78	190,240
Painted Lady ( <i>Vanessa cardui</i> )	134 (11%)	1.07 ± 5.68	817,575
Buckeye ( <i>Junonia coenia</i> )	120 (10%)	0.96 ± 4.74	728,939
Variegated Fritillary ( <i>Euptoieta claudia</i> )	106 (8%)	0.84 ± 2.57	642,981
Red Admiral ( <i>Vanessa atalanta</i> )	102 (8%)	0.81 ± 2.91	619,239
Question Mark ( <i>Polygonia interrogationis</i> )	33 (3%)	0.27 ± 1.04	203,450
Goatweed Butterfly ( <i>Anaea andria</i> )	16 (1%)	0.13 ± 0.64	97,890
Common Snout Butterfly ( <i>Libytheana carinenta</i> )	14 (1%)	0.11 ± 0.43	86,202
Tawny Emperor ( <i>Asterocampa clyton</i> )	12 (1%)	0.09 ± 0.57	70,739
Gulf Fritillary ( <i>Agraulis vanillae</i> )	11 (1%)	0.09 ± 0.35	67,451
Queen ( <i>Danaus gilippus</i> )	4 (0%)	0.03 ± 0.23	26,542
<i>Pieridae</i>	606 (48%)	4.85 ± 12.37a	3,689,743
Orange Sulphur ( <i>Colias eurytheme</i> )	489 (39%)	3.91 ± 11.39	2,977,241
Lyside Sulphurs ( <i>Kricogonia lyside</i> )	49 (4%)	0.39 ± 1.99	299,514
Southern Dogface ( <i>Zerene cesonia</i> )	37 (3%)	0.30 ± 1.13	225,609
Sleepy Orange ( <i>Abaeis nicippe</i> )	9 (1%)	0.07 ± 0.28	56,372
Little Yellow ( <i>Pyristia lisa</i> )	8 (1%)	0.06 ± 0.47	48,093
Cabbage White ( <i>Pieris rapae</i> )	6 (0%)	0.05 ± 0.28	35,917
Large Orange Sulphur ( <i>Phoebis agarithe</i> )	3 (0%)	0.03 ± 0.21	19,359
Colias sp. ( <i>Colias philodice</i> )	1 (0%)	0.01 ± 0.11	7,183
Other Pieridae (Pieridae spp.)	3 (0%)	0.03 ± 0.17	20,455
<i>Papilionidae</i>	26 (2%)	0.21 ± 0.62	160,349
Pipevine Swallowtail ( <i>Battus philenor</i> )	12 (1%)	0.10 ± 0.47	73,539
Black Swallowtail ( <i>Papilio polyxenes</i> )	9 (1%)	0.07 ± 0.34	55,276
Swallowtails ( <i>Papilio</i> sp.)	5 (0%)	0.04 ± 0.27	31,534
<i>Lycaenidae</i>	8 (1%)	0.07 ± 0.55	49,797
Reakirt's Blue ( <i>Echinargus isola</i> )	2 (0%)	0.02 ± 0.14	13,271



**Table 2. Arthropod 100 m x 1 m transect roadkill counts (includes extrapolations to uncounted sides) for various taxa in spring 2020 monarch migratory Central Funnel and eastwards.<sup>a</sup>**

Taxa/Species	Roadkill Counts (Percent of Taxa)	Roadkill per 100m x 2m Transect (Mean ± SD) (n = 124 transects)	Estimated Total Roadkill = (Estimated Roadkill per 100m x 2m) x 10 transects/km x Km Length Highways <sup>b</sup>
Hairstreaks (Theclinae)	6 (0%)	0.05 ± 0.54	36,526
<i>Hesperiidae</i> (Skippers)	5 (0%)	0.04 ± 0.20	27,638
<i>Sphingidae</i> (Sphinx Moths)	21 (2%)	0.16 ± 0.79	125,528
Other Heterocera (Moths)	7 (1%)	0.06 ± 0.29	43,101

<sup>a</sup>See text for ratios used to extrapolate roadkill counts on unsampled side of roadway from sampled side.

<sup>b</sup>Length of highways is 76,096 km from Table 1.

**Table 3. Lepidoptera roadkill spatial correlations ( $r_s$ ) for fall 2019 in monarch fall migratory Central and Coastal funnels of Texas for 100m transects spatially thinned to 10 km.<sup>a</sup>**

Species	Monarch	Painted Lady	Buckeye	Variegated Fritillary	Orange Sulphur
Monarch	1.00	0.40*	0.43*	0.39*	0.40*
Painted Lady		1.00	0.46*	0.28*	0.47*
Buckeye			1.00	0.26*	0.34*
Variegated Fritillary				1.00	0.54*
Orange Sulphur					1.00

<sup>a</sup>Asterisks indicate significant correlation ( $P < 0.05$ ; paired Spearman rank order correlations with Holm's correction for multiple comparisons).

**Table 4. Milkweed plant 100m x 5m transect counts in spring 2020 monarch migratory Central Funnel and eastwards.**

Species	Plant Counts (Percent of Taxa) (n = 2005 plants) <sup>a</sup>	Plants per 100m x 5m Transect (Mean ± SD) (n = 106 dispersed transects) <sup>b</sup>	Mean Stems per Plant (Mean ± SD) (n) <sup>a</sup>	Estimated Stems per Species = Plant Count x Mean Stems Per Plant (Percent of Taxa) (n = estimated 7,804 stems) <sup>a</sup>	Mean Length Longest Stems per Plant (cm) (Mean ± SD) (n) <sup>a</sup>
Green antelopehorn ( <i>Asclepias viridis</i> )	1,126 (56%)	6.71 ± 22.74	1.95 ± 1.63 (224)	2,192 (28%)	41.26 ± 15.12 (224)
Antelopehorns ( <i>A. asperula</i> ssp. <i>capricornu</i> )	592 (30%)	4.79 ± 17.75	8.33 ± 10.18 (209)	4,931 (63%)	37.7 ± 8.42 (209)
Zizotes Milkweed ( <i>A. oenotheroides</i> )	200 (10%)	1.5 ± 5.6	2.47 ± 1.63 (224)	495 (6%)	21.33 ± 8.93 (224)
Broadleaf Milkweed ( <i>A. latifolia</i> )	61 (3%)	0.08 ± 0.65	1.96 ± 1.3 (24)	119 (2%)	26.25 ± 9.19 (24)
Green Comet Milkweed ( <i>A. viridiflora</i> )	5 (<1%)	0.41 ± 4.2	1.43 ± 0.79 (7)	7 (0%)	29.2 ± 15.18 (7)
Other Milkweeds ( <i>Asclepias</i> spp.) <sup>d</sup>	15 (1%)	0.11 ± 0.34	3.29 ± 2.63 (7)	49 (1%)	42.71 ± 20.78 (7)
<b>Total</b>	<b>2005 (100%)</b>	<b>13.26 ± 28.46</b>		<b>7,804 (100%)</b>	

<sup>a</sup>From data of all 125 transects, including both 106 dispersed (85% spaced) and 19 adventitious (15% non-spaced) transects. Five (4%) of 125 transects counted on both sides of highway (counts halved). Total of 50 of 106 dispersed transects (47% of total) had milkweeds.

<sup>b</sup>From data of 106 dispersed transects only.

<sup>c</sup>Length of highways is 76,096 km from Table 1.

<sup>d</sup>Five other milkweed species: *A. verticillata* (whorled milkweed, adventitious transects only), *A. longifolia* (longleaf milkweed; outside of 5 m width only), *A. emoryi* (Emory's milkweed), *A. pumila* (plains milkweed), and *A. tuberosa* (butterflyweed, adventitious transect).

**Table 5. Monarch-preferred nectar plant 50 m x 5 m dispersed transect percent cover for various taxa in April-May 2020 monarch migratory Central Funnel and eastwards.<sup>a</sup>**

Species	Total Percent Cover (Percent of Species)	Percent Cover per 50m x 5m Transect (Mean ± SD) (n = 106 dispersed transects)	Estimated Total Area (Ha.) within 5 m Roadway = [(Percent Cover/(0.05 km x 0.005km) x 2 x 0.005 km x km Length Highways]*100 ha/sq km] <sup>b</sup>
Lance Leaved Coreopsis ( <i>Coreopsis lanceolata</i> )	12 (9%)	0.81 ± 5.9	6,373
Engelmann Daisy ( <i>Engelmannia peristenia</i> )	13 (9%)	0.44 ± 2.54	3,465
Texas Vervain ( <i>Verbena halei</i> )	33 (24%)	0.42 ± 1.24	3,345
Maltese Star Thistle ( <i>Centaurea melitensis</i> ) (Exotic)	2 (1%)	0.38 ± 3.08	3,013
Black Eyed Susan ( <i>Rudbeckia hirta</i> )	4 (3%)	0.1 ± 0.69	814
Blue Mealy Sage ( <i>Salvia farinacea</i> )	1 (1%)	0.1 ± 0.98	753
Wavy-leaf Thistle ( <i>Cirsium undulatum</i> )	1 (1%)	0.1 ± 0.98	753
Climbing Milkweed Vine ( <i>Funastrum cynanchoides</i> )	8 (6%)	0.08 ± 0.38	648
Lemon Beebalm ( <i>Monarda citriodora</i> )	9 (6%)	0.08 ± 0.38	633
Texas Thistle ( <i>Cirsium texanum</i> )	10 (7%)	0.07 ± 0.27	542
Bristle Thistle ( <i>Cirsium horridulum</i> )	9 (6%)	0.06 ± 0.31	467
Prairie Verbena ( <i>Glandularia bipinnatifida</i> )	6 (4%)	0.04 ± 0.2	301
Green Antelopehorn** ( <i>Asclepias viridis</i> )	7 (5%)	0.04 ± 0.16	--
Texas Sage ( <i>Salvia texana</i> )	4 (3%)	0.03 ± 0.2	271
Vervain sp. ( <i>Verbena</i> sp.)	3 (2%)	0.03 ± 0.2	241
Goldemane Tickseed ( <i>Coreopsis basalis</i> )	1 (1%)	0.03 ± 0.29	226
Brazilian Vervain ( <i>Verbena brasiliensis</i> ) (Exotic)	4 (3%)	0.02 ± 0.15	196
Zizotes Milkweed ( <i>Asclepias oenotheroides</i> )**	6 (4%)	0.02 ± 0.09	--
Antelopehorn Milkweed ( <i>Asclepias asperula</i> ssp. <i>capricornu</i> )**	4 (3%)	0.02 ± 0.12	--
Zexmenia ( <i>Wedelia acapulcensis</i> var. <i>hispida</i> )	1 (1%)	0.01 ± 0.14	105
Spotted Beebalm ( <i>Monarda fruticosa</i> )	1 (1%)	0 ± 0.04	30
<b>Total</b>			<b>22,177</b>

<sup>a</sup>Plots are biased towards milkweed for which searches were made over 100 km units. Includes two exotic species out of 21 species total (noted in parentheses). Plants with two bold asterisks (\*\*) are rated "Very High Value" for monarchs, while other plants are "High Value" (USDA NRCS 2018, Pollinator Partnership 2013, Ajilvsgi 2013). Other minor species found in the few dispersed transects on other side of road that were not included in this table include blue mistflower (*Conoclinium coelestinum*), broadleaf milkweed (*Asclepias latifolia*), and downy paintbrush (*Castilleja purpurea*).

<sup>b</sup>Length of highways is 76,096 km from Table 1. Milkweed values were not extrapolated since plots were biased towards presence of milkweed.

**Table 6. Monarch larvae per milkweed plant for roadside transects.<sup>a</sup>**

Statistic	Green Antelopehorn	Antelopehorns	Zizotes Milkweed	All Milkweeds <sup>b</sup>
<i>Monarch Larvae per Milkweed Plant</i>				
Total Larvae	14	10	3	27
Mean Larvae ±	0.06 ± 0.43a	0.05 ± 0.24a	0.03 ± 0.28a	0.05 ± 0.33
SD (n) [Range]	(224) [0-5]	(209) [0-2]	(118) [0-3]	(551) [0-5]

<sup>a</sup>Data summed over all transects. Up to six milkweed plants per species were examined for larvae in each 100m x 5m roadside transect. Means in the same row with the same letter are not significantly different (P < 0.05; Kruskal-Wallis Test).

<sup>b</sup>Nine percent of 106 dispersed transects (10) had monarch larvae and 11% of 19 adventitious transects (2) had monarch larvae.



Figures

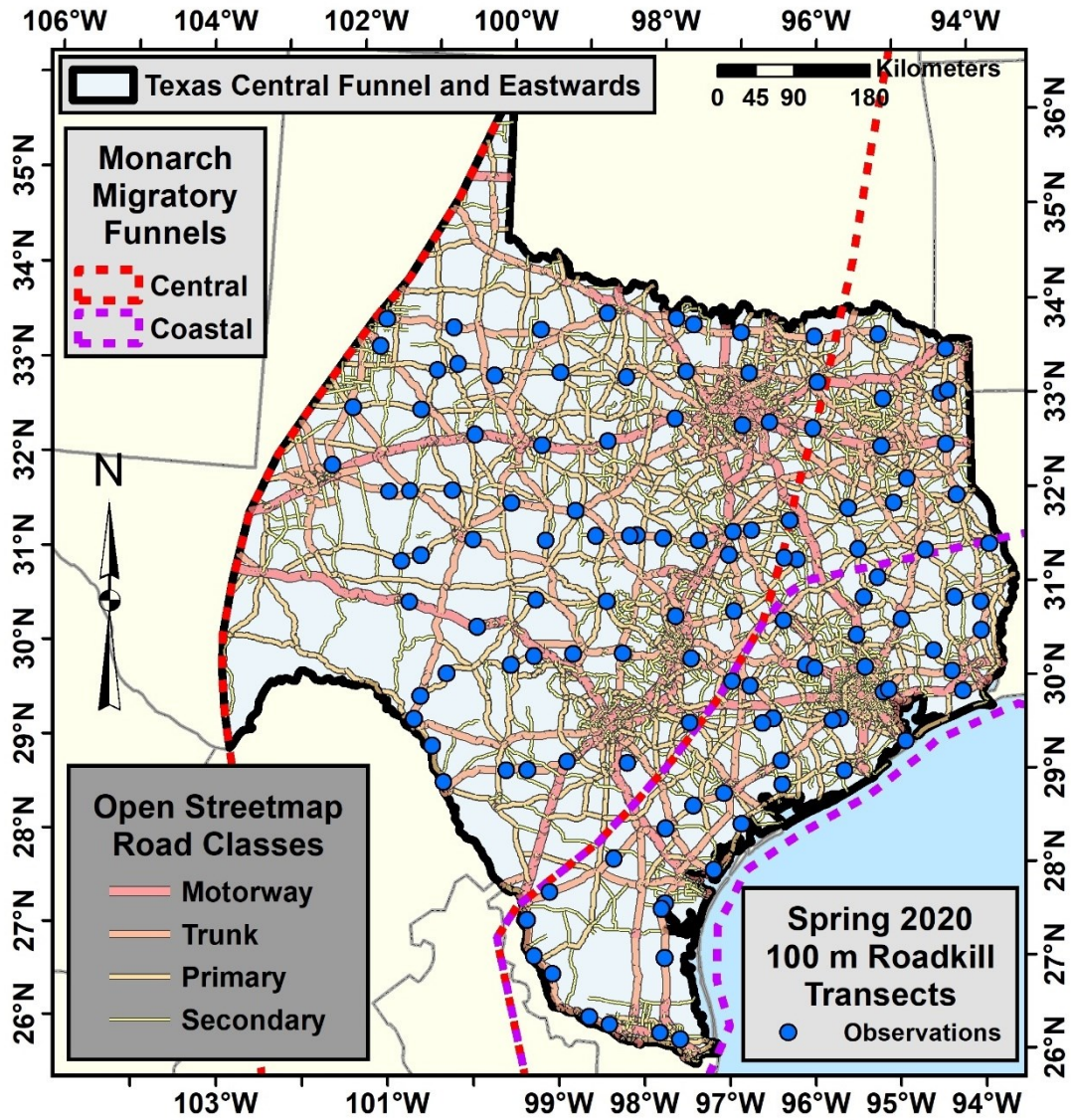


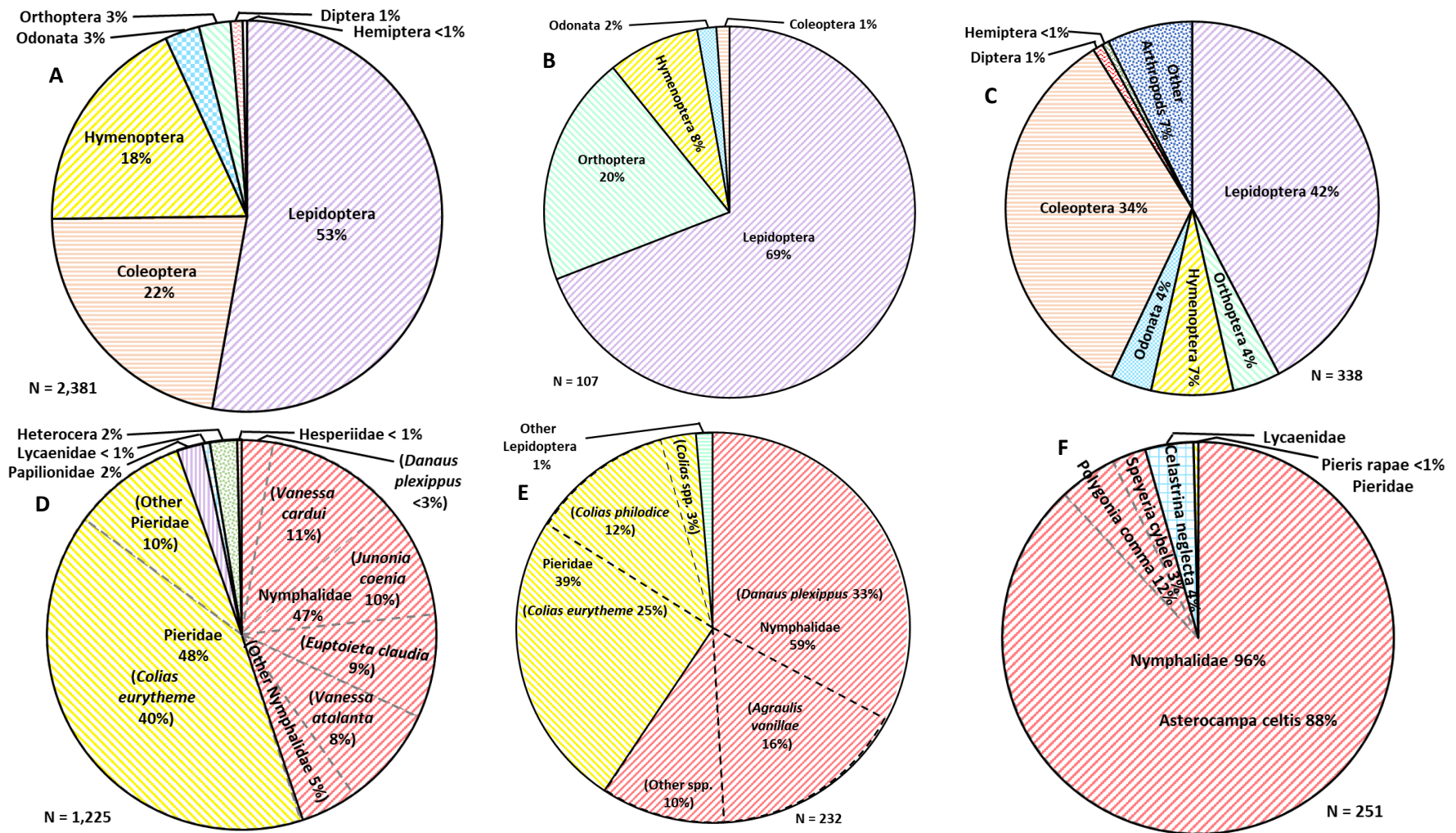
Figure 1. Distribution of spring 2020 100m x 1m roadkill transects over Texas roadways within the monarch migratory Central Funnel and eastwards.





**Figure 2. (A) Spring 2020 field assistants Jasper Klein (left) and Anna Capri Perez (right) measuring milkweed in a 100m x 5 m transect; (B) Antelopehorns, 10 km west of Mountain Home on Texas State Highway 41 (4/15/20); (C) Antelopehorns, 34 km north of Del Rio on edge of US Highway 277 (4/15/20) ; (D) First generation monarch nectaring on Brazilian vervain (exotic), 4 km north of Crockett along US Highway 277 (4/27/20); (E) Fifth instar monarch larvae on antelopehorn, 25 km west of Mason along US Highway 377 (4/30/20); (F) Roadkilled monarch, West Point on Texas State Highway 71 (4/16/20).**





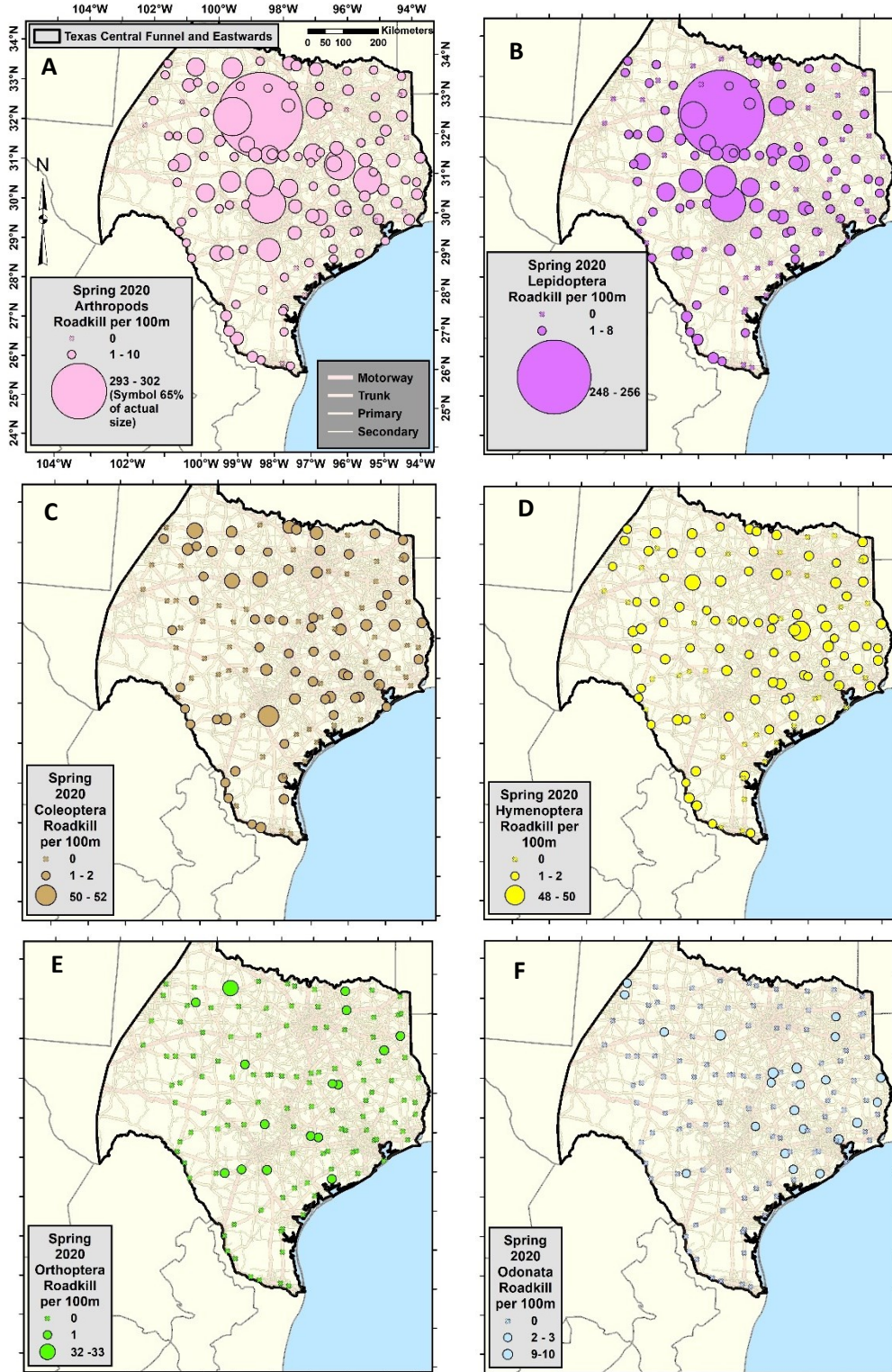
**Figure 3. Percentage roadkill among roadside transects for arthropod (A-C) and lepidoptera (D-F) taxa in North America and Europe: (A,D) Central Funnel and Eastwards in Texas, Apr-May 2020 (Table 2), (B,E) Texas Central Funnel, Sep-Dec 2019 (Tracy et al. 2020); (C) roadways in Flanders, Belgium, Oct 2013-Feb 2017 (Vercayie and Lambrechts 2017); (F) forest/farmland gravel roads, Douglas and Jefferson Counties, Northeast Kansas, 5-8 June 2015 (Barrows 2018).**





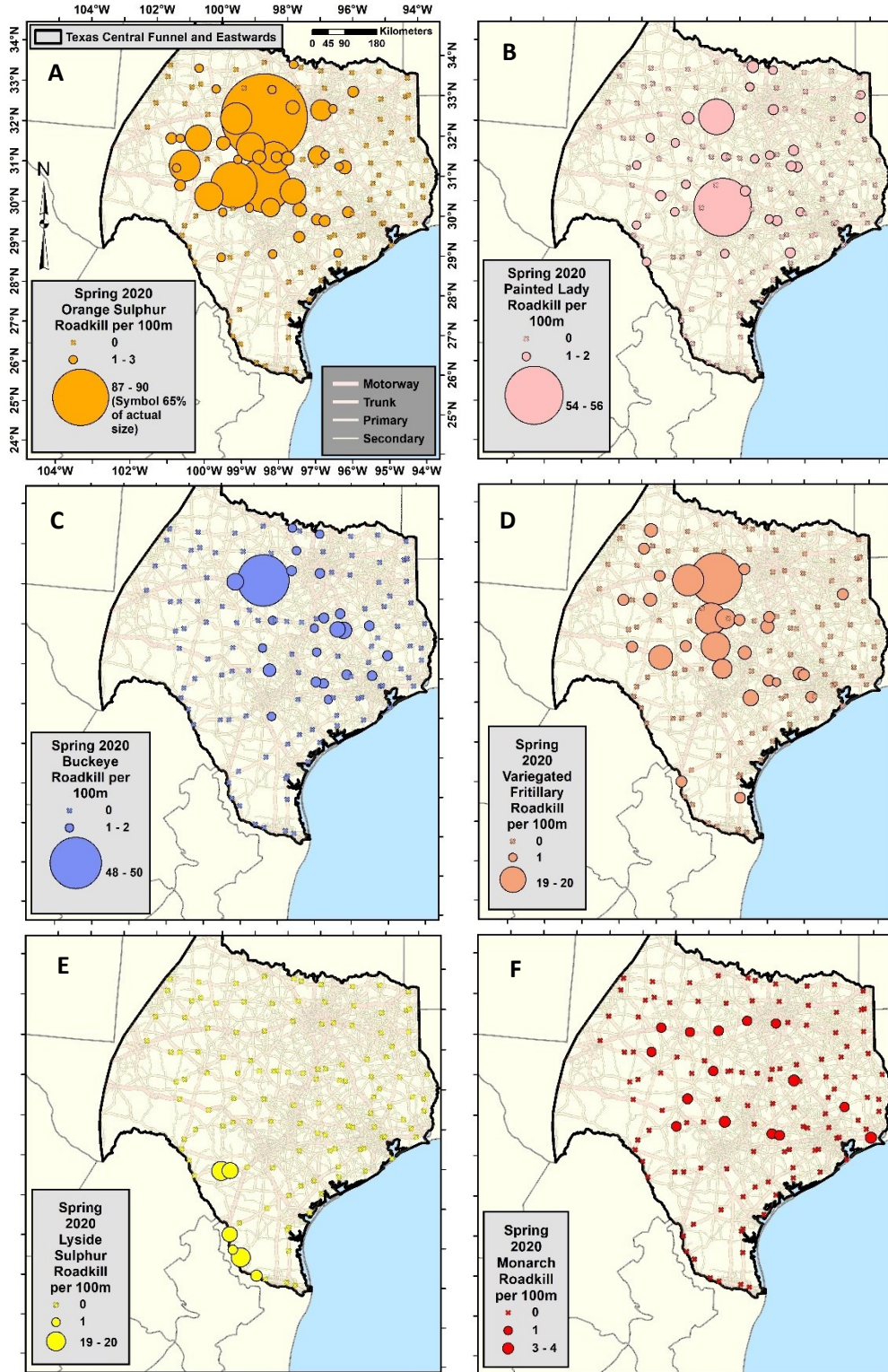
**Figure 4. Most common butterfly species in spring 2020 Texas roadkill: (A) orange sulphur, *Colias eurytheme*; (B) painted lady, *Vanessa cardui*; (C) buckeye, *Junonia coenia*; (D) variegated fritillary, *Euptoieta claudia*; (E) red admiral, *Vanessa atalanta*; (F) lyside sulphur, *Kricogonia lyside*; (G) southern dogface, *Zerene cesonia*; and (H) question mark, *Polygonia interrogationis* (images, iNaturalist 2020 and BugGuide.Net 2020).**



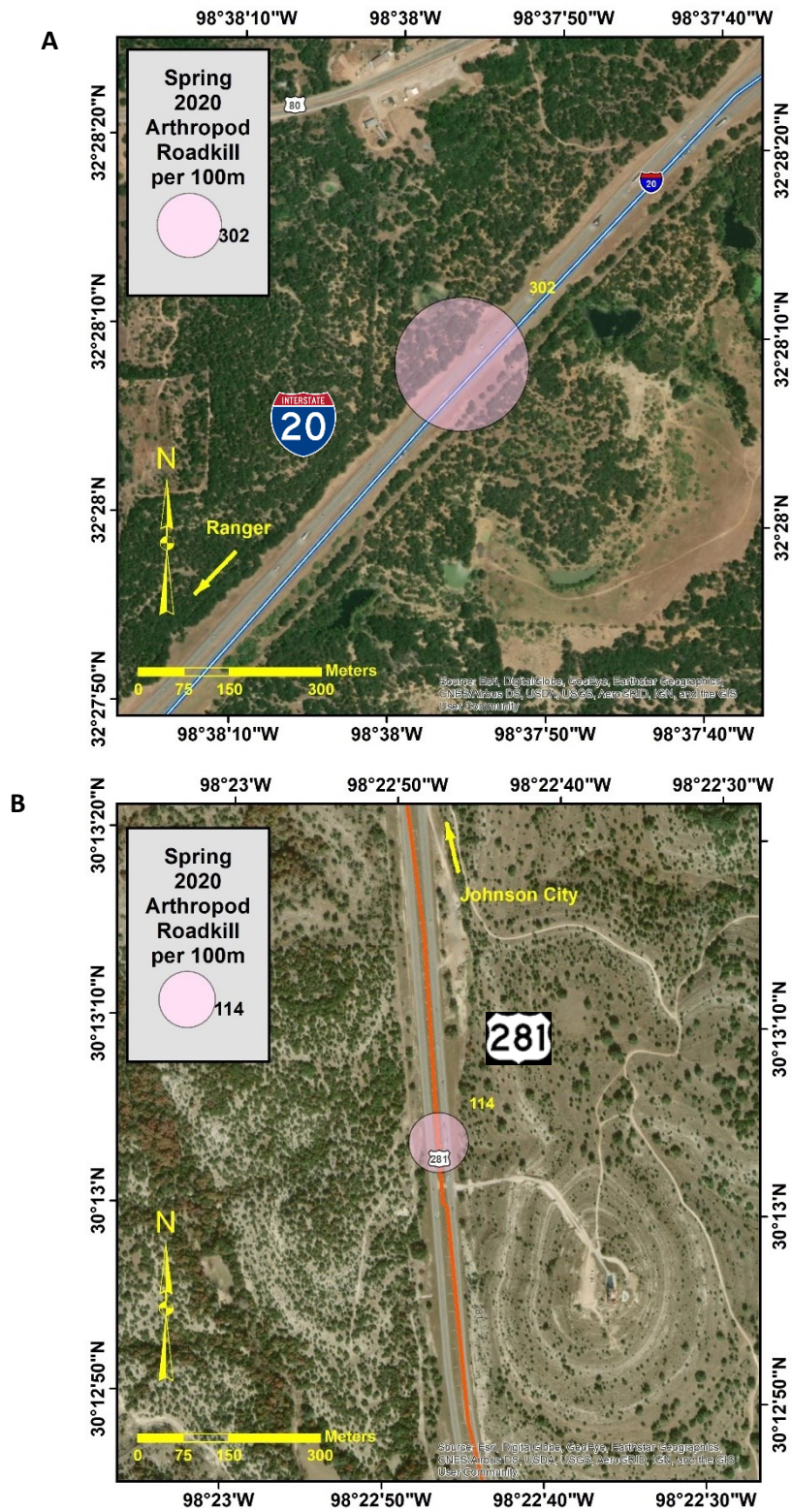


**Figure 5. Distribution of spring 2020 roadkill per 100m x 1m transect (unthinned) for various arthropod taxa in Texas monarch migratory Central Funnel and eastwards: (A) Arthropods; (B) Lepidoptera; (C) Coleoptera; (D) Hymenoptera; (E) Orthoptera; and (F) Odonata (symbols ca. proportional among taxa).**



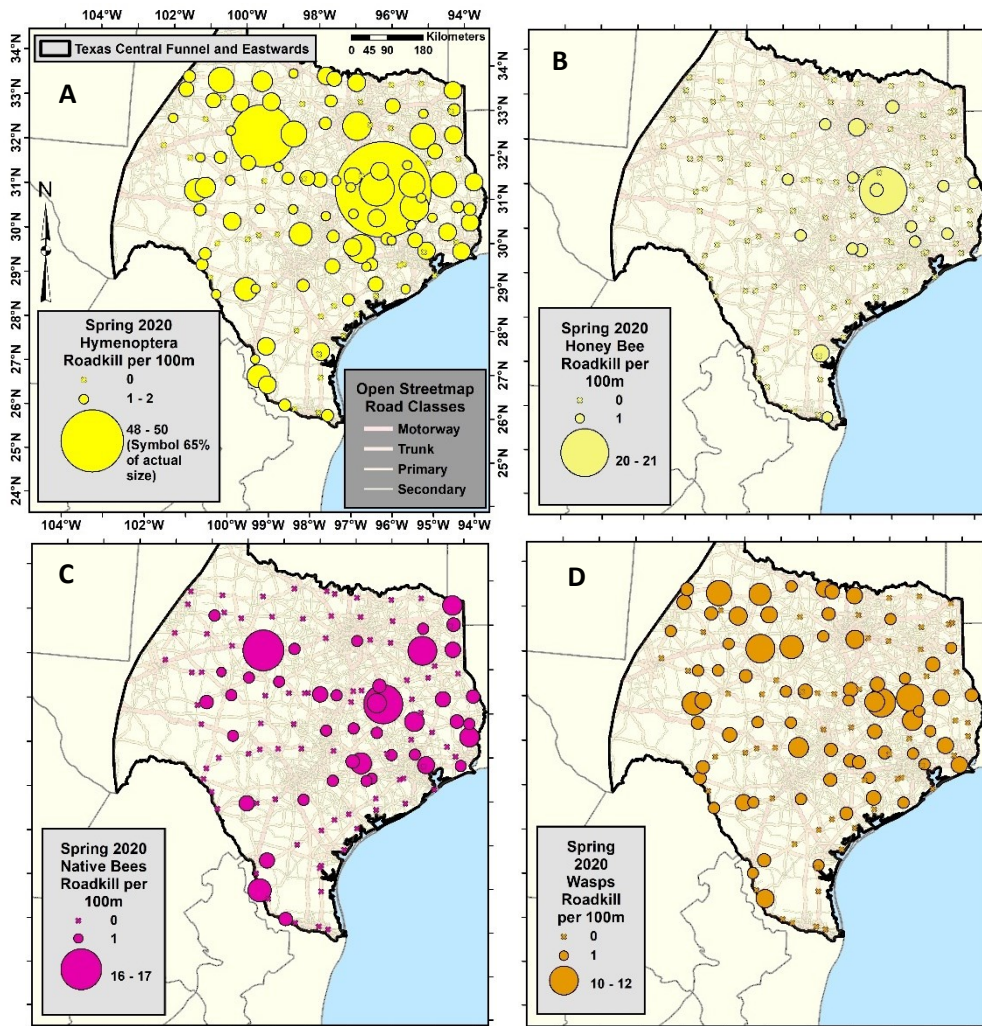


**Figure 6. Distribution of spring 2020 roadkill per 100m x 1m transect (unthinned) for Lepidoptera taxa in Texas monarch migratory Central Funnel and eastwards: (A) Orange Sulphur; (B) Painted Lady; (C) Buckeye; (D) Variegated Fritillary; (E) Lyside Sulphur; and (F) Monarch (symbols ca. proportional among taxa).**

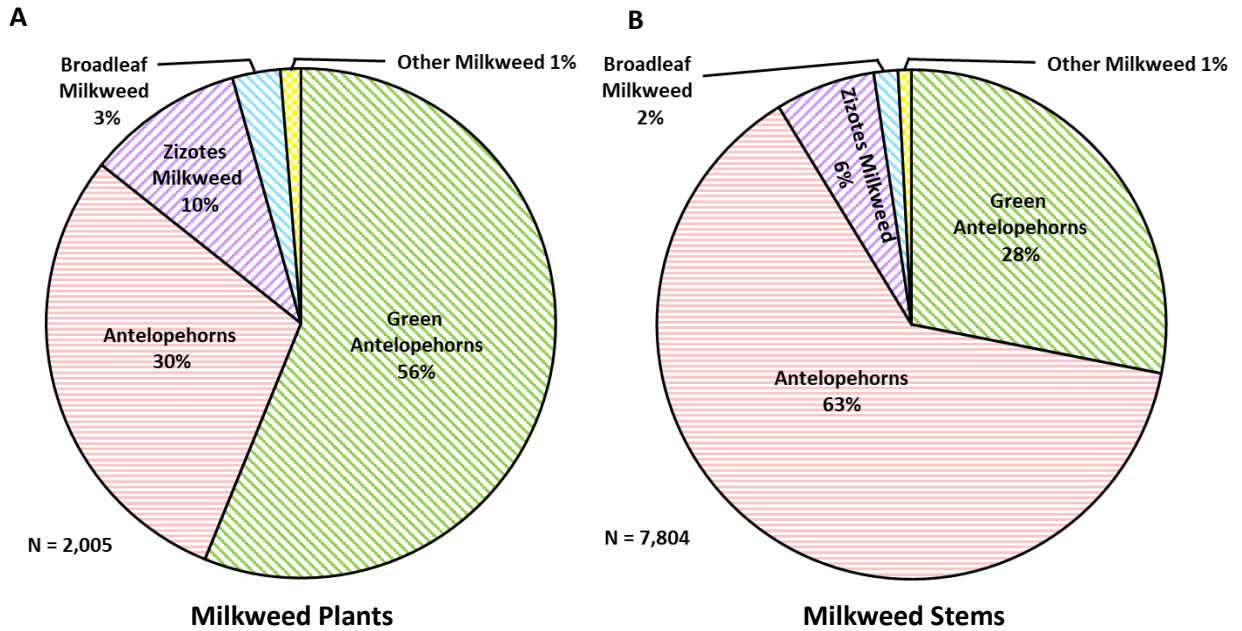


**Figure 7. Arthropod roadkill hotspot zones (A) 4 km northeast of Ranger along Interstate Highway 20 on 13 May, 2020; and (B) 6.4 km south of Johnson City along US Highway 281 on 16 April, 2020 (see also Fig. 12B).**





**Figure 8. Distribution of spring 2020 roadkill per 100m x 1m transect (unthinned) for Hymenoptera taxa in Texas monarch migratory Central Funnel and eastwards: (A) Hymenoptera; (B) European Honey Bees; (C) Native Bees; and (D) Wasps (symbols ca. proportional among taxa).**

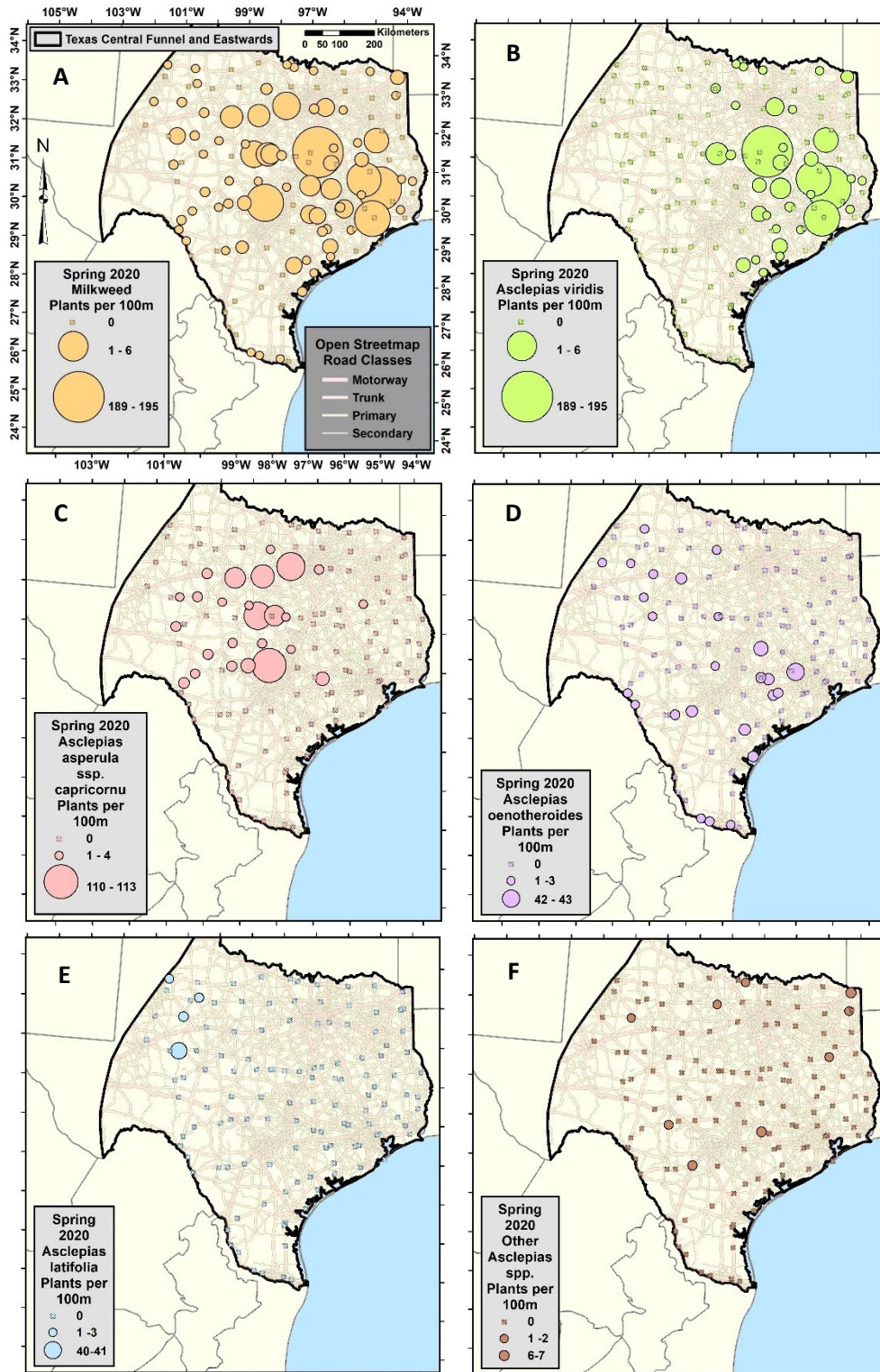


**Figure 9. Percentage (A) milkweed plants and (B) estimated milkweed stems along roadside transects for Central Funnel and Eastwards in Texas, Apr-May 2020 (see Table 3 for data and species of other milkweeds).**



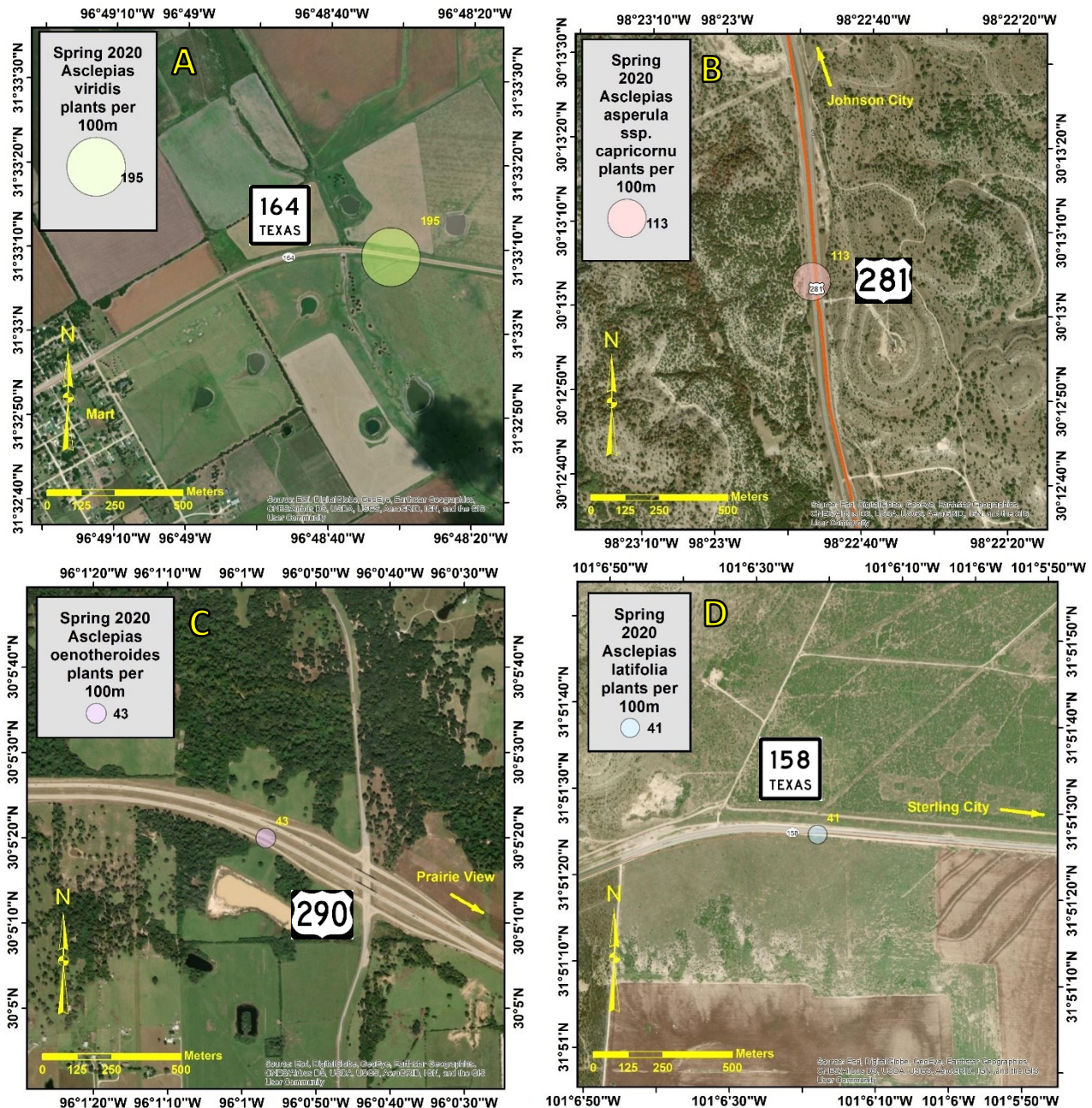
**Figure 10. Most common milkweed species in spring 2020 Texas transects: (A) Green antelopehorn, *Asclepias viridis*; (B) Antelopehorns, *A. asperula* ssp. *capricornu*; (C) Zizotes milkweed, *A. oenotheroides*; (D) Broadleaf milkweed, *A. latifolia*; (E) Green comet milkweed, *A. viridiflora*, and (F) Whorled milkweed, *A. verticillata* (images, iNaturalist 2020).**



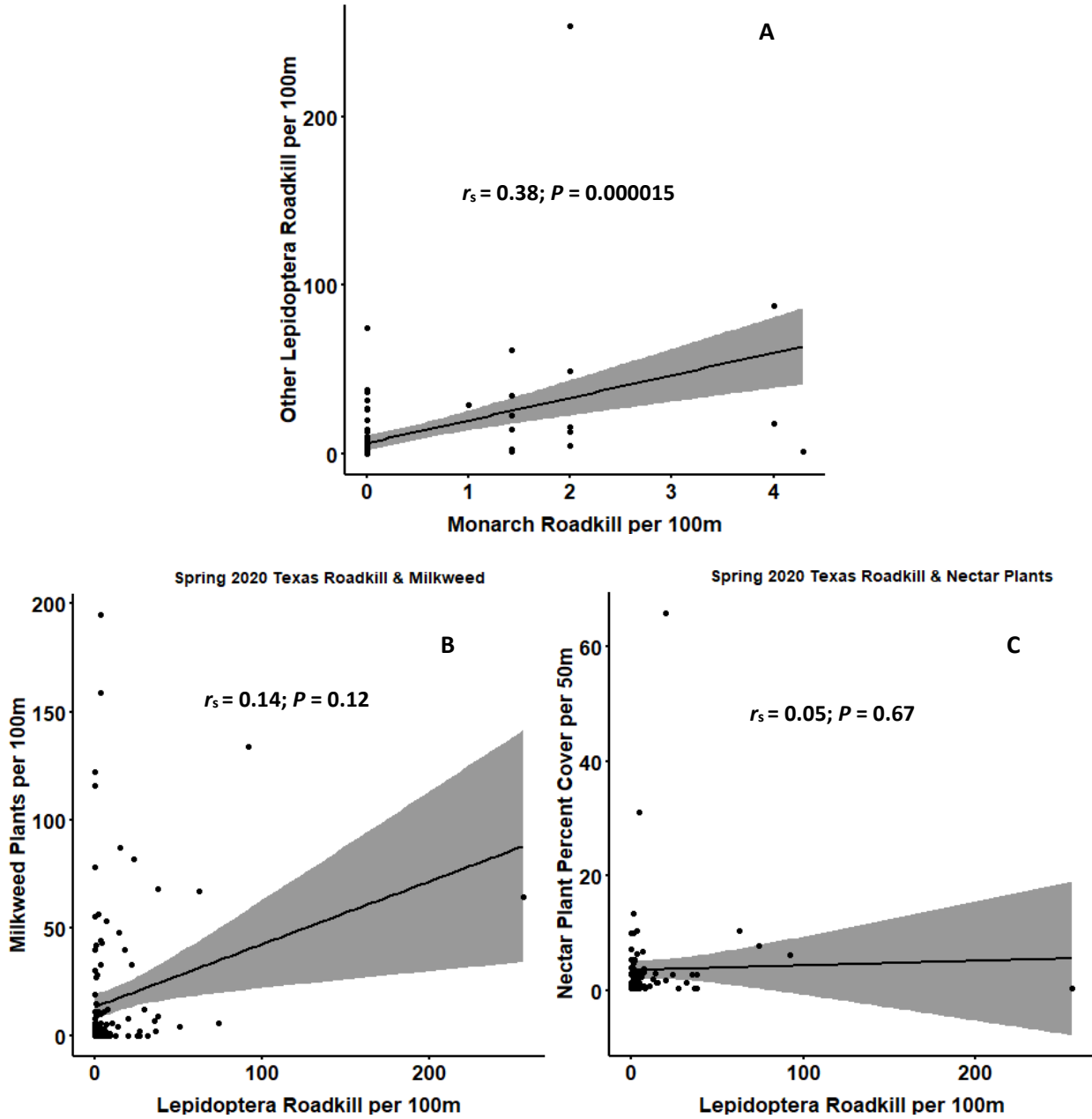


**Figure 11. Distribution of spring 2020 milkweed plants per 100m x 5 m transect (unthinned) in Texas monarch migratory Central Funnel and eastwards: (A) All milkweeds; (B) Green antelopehorn; (C) Antelopehorns; (D) Zizotes milkweed; (E) Broadleaf milkweed; and (F) Other milkweeds (symbols ca. proportional among taxa).**





**Figure 12. Milkweed plant hotspots for (A) Green antelopehorn, 1.2 km east of Mart along Texas State Highway 164 on 11 May, 2020 (adventitious transect); (B) Antelopehorns, 6.4 km south of Johnson City along US Highway 281 on 16 April, 2020 (dispersed transect); (C) Zizotes milkweed, 2.7 km west of Prairie View along US Highway 290 on 1 May 2020 (dispersed transect); and (D) Broadleaf milkweed, 11 km northwest Sterling City along Texas State Highway 158 on 14 May, 2020 (adventitious transect).**



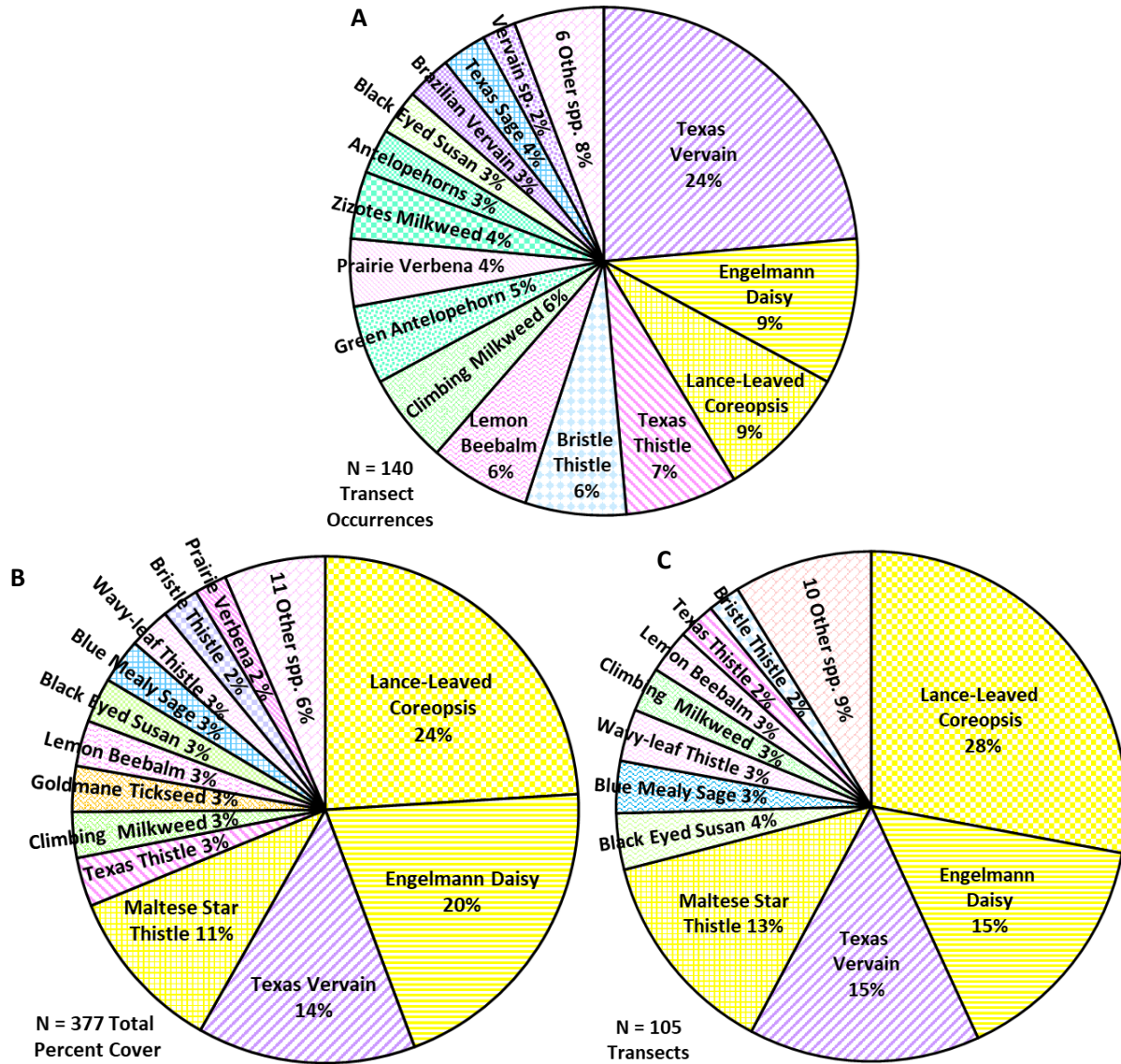
**Figure 13. Spearman’s rank order correlation ( $r_s$ ) between (A) monarch roadkill per 100m x 5m roadside transect and other Lepidoptera roadkill per transect; and all Lepidoptera roadkill per transect and (B) milkweed plants per transect; or (C) percent cover monarch-preferred nectar plants per 50 m x 5 m plot within transect.**



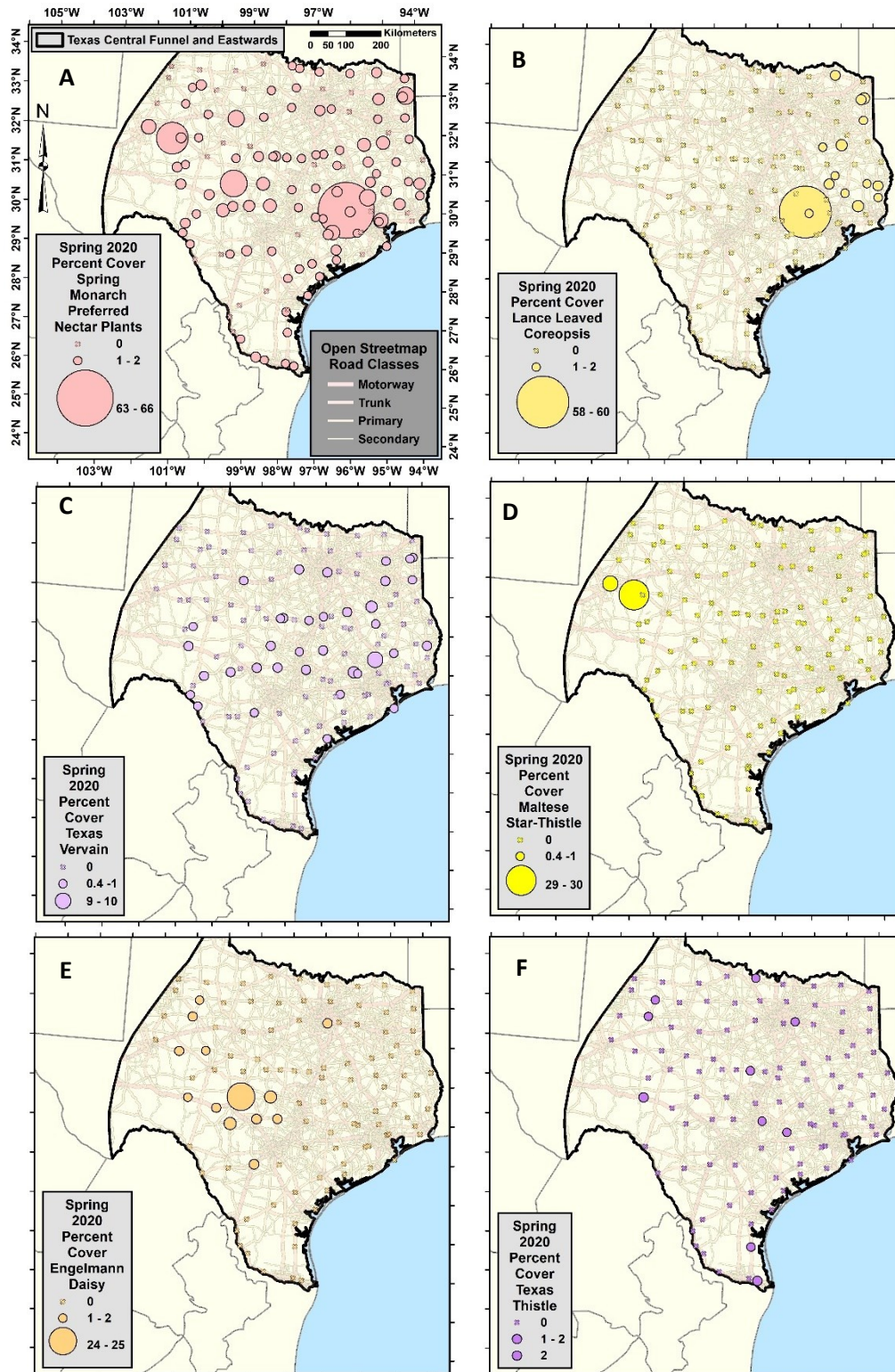


**Figure 14. Major native roadside monarch preferred nectar plants (in addition to top three milkweeds, Fig. 10A-C) in Texas for April-May 2020: (A) Texas vervain, *Verbena halei*; (B) Engelmann daisy, *Engelmanna peristenia*, (C) Lance leaved coreopsis, *Coreopsis lanceolata*, (D) Texas thistle, *Cirsium texanum*; (E) Bristle thistle, *Cirsium horridulum*; (F) Lemon beebalm, *Monarda citriodora*; (G) Climbing milkweed vine, *Funastrum cynanchoides*; (F) Prairie verbena, *Glandularia bipinnatifida*; (I) Black-eyed susan, *Rudbeckia hirta*; and (J) Texas sage, *Salvia texana* (images, iNaturalist 2020).**



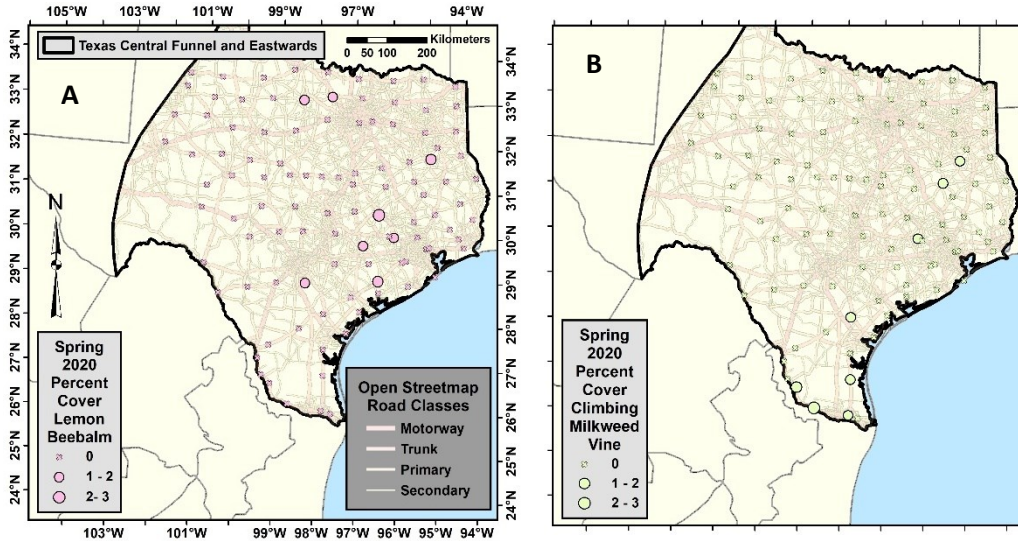


**Figure 15. Percentages of monarch preferred spring nectar plants along 50 m x 5 m roadside dispersed transects for Central Funnel and Eastwards in Texas, Apr-May 2020: (A) Percent of transect plant occurrence records; (B) Percent of total percent covers across all transects; and (C) Percent of total mean percent covers per transect.**

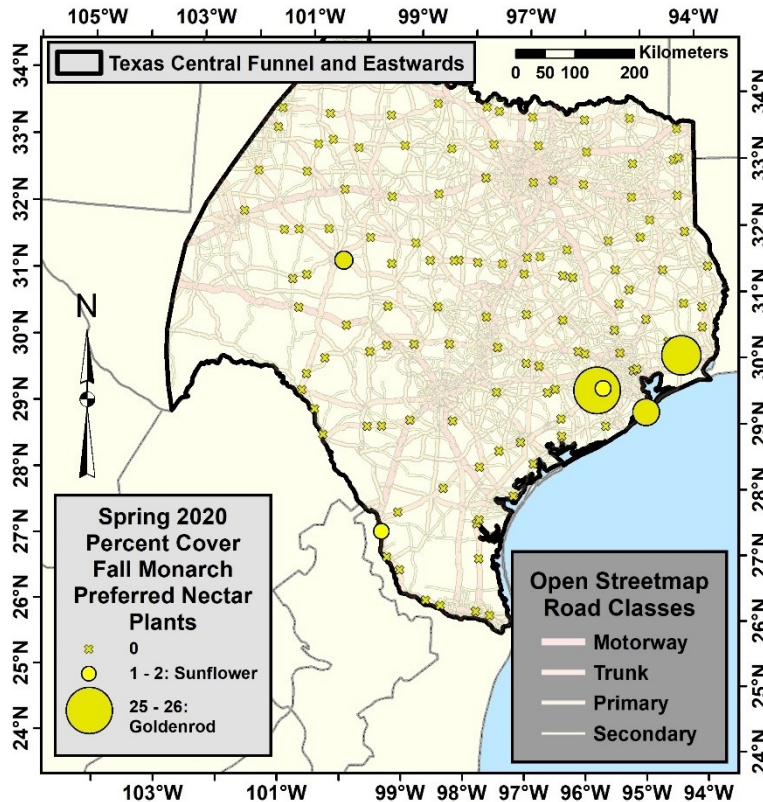


**Figure 16. Spring 2020 percent cover of monarch-preferred nectar plants per 50m x 5m transect (unthinned) in Texas monarch migratory Central Funnel and eastwards for (A) All species (70%, 74 of 106 dispersed transects with nectar plants); (B) Lance leaved coreopsis; (C) Texas vervain; (D) Maltese star-thistle (exotic); (E) Engelmann daisy; and (F) Texas thistle (symbols ca. proportional among taxa).**

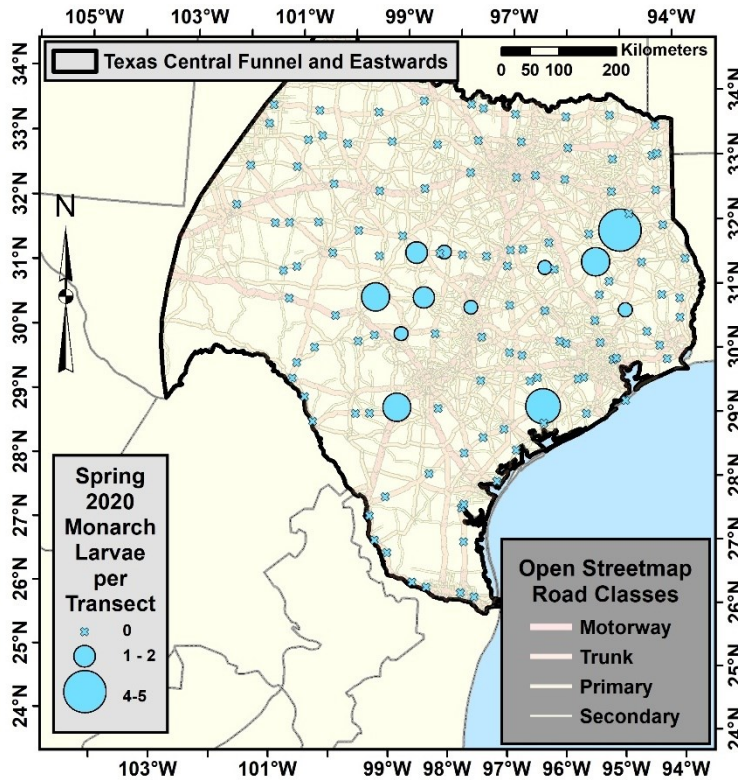




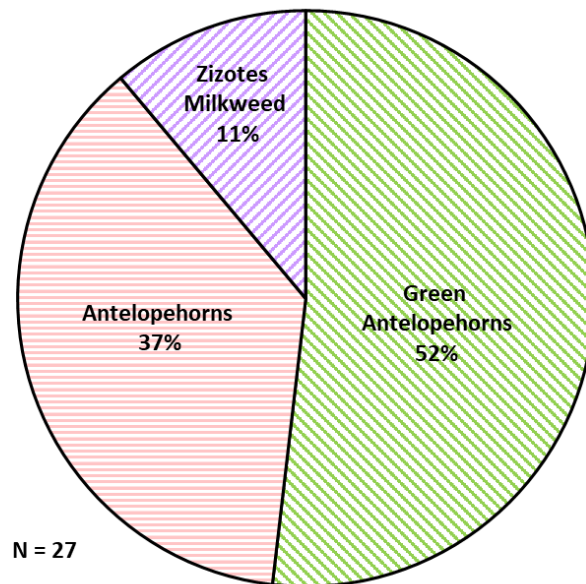
**Figure 17. Distribution of spring 2020 percent cover of preferred monarch nectar plants per 50m x 5m transect (unthinned) in Texas monarch migratory Central Funnel and eastwards for (A) Lemon beebalm; and (B) Climbing milkweed vine (symbols ca. proportional among taxa).**



**Figure 18. Distribution of spring 2020 percent cover of immature fall preferred monarch nectar plants per 50m x 5m transect (unthinned) in Texas monarch migratory Central Funnel and eastwards for annual sunflower and goldenrods.**



**Figure 19. Distribution of spring 2020 numbers of monarch larvae in 12 of 125 total 100 x 5 m transects (unthinned) for Texas monarch migratory Central Funnel and eastwards. Larvae found on six transects from *Asclepias viridis*, five transects from *A. asperula*, and 1 transect from *A. oenotheroides*. Ten (9%) of 106 dispersed transects had monarch larvae.**



**Figure 20. Percentage monarch larvae among different milkweed species along roadside transects for Central Funnel and Eastwards in Texas, Apr-May 2020.**



## References

- Ajilvsgi, G. 2013. *Butterfly Gardening for Texas* (No. 46). Texas A&M University Press. Available at: [https://books.google.com/books?id=IWhdACADM58C&printsec=frontcover&source=gbs\\_ge\\_summary\\_r&cad=0#v=onepage&q=monarch&f=false](https://books.google.com/books?id=IWhdACADM58C&printsec=frontcover&source=gbs_ge_summary_r&cad=0#v=onepage&q=monarch&f=false)
- Barrows, E.M. 2018. A Huge 2015 butterfly feeding aggregation in Northeastern Kansas, USA, with comparative notes (Lepidoptera: Lycaenidae, Nymphalidae, Pieridae). *Journal of the Kansas Entomological Society*, 91(2):133-143.
- Baum, K.A. and Mueller, E.K. 2015. Grassland and roadside management practices affect milkweed abundance and opportunities for monarch recruitment. In: Oberhauser, K.S., Nail, K.R., and Altizer, S. (eds.), *Monarchs in a Changing World: Biology and Conservation of an Iconic Butterfly*, Cornell University Press, Ithaca, New York, pp.197-202.
- Geofabrik (2017) OpenStreetMap Data Extracts. Accessed at: <http://download.geofabrik.de/>
- Halbritter, D.A., Daniels, J.C., Whitaker, D.C. and Huang, L. 2015. Reducing mowing frequency increases floral resource and butterfly (Lepidoptera: Hesperioidea and Papilionoidea) abundance in managed roadside margins. *Florida Entomologist*, 98(4):1081-1092.
- Hartzler, R. G., and Buhler, D. D. 2000. Occurrence of common milkweed (*Asclepias syriaca*) in cropland and adjacent areas. *Crop Protection*, 19(5):363-366.
- iNaturalist. 2020. *Observations*. Accessed at: <https://www.inaturalist.org/observations/>
- Kantola, T., Tracy, J.L., Baum, K.A., Quinn, M.A., and Coulson, R.N. 2019. Spatial risk assessment of eastern monarch butterfly road mortality during autumn migration within the southern corridor. *Biological Conservation*, 231:150-160.
- Kasten, K., Stenoien, C., Caldwell, W. and Oberhauser, K.S. 2016. Can roadside habitat lead monarchs on a route to recovery?. *Journal of Insect Conservation*, 20(6):1047-1057.
- McKenna, D.D., McKenna, K.M., Malcom, S.B., and Berenbaum, M.R. 2001. Mortality of Lepidoptera along roadways in central Illinois. *Journal of Lepidopterists' Society*, 55 (2): 63-68.
- Pollinator Partnership. 2013. *Monarch Habitat Development on Utilities Rights of Way*. 32 pp. Available at: <https://www.pollinator.org/pollinator.org/assets/generalFiles/Monarch.Habitat.Manual.ROW.SouthEast.ver3.pdf>

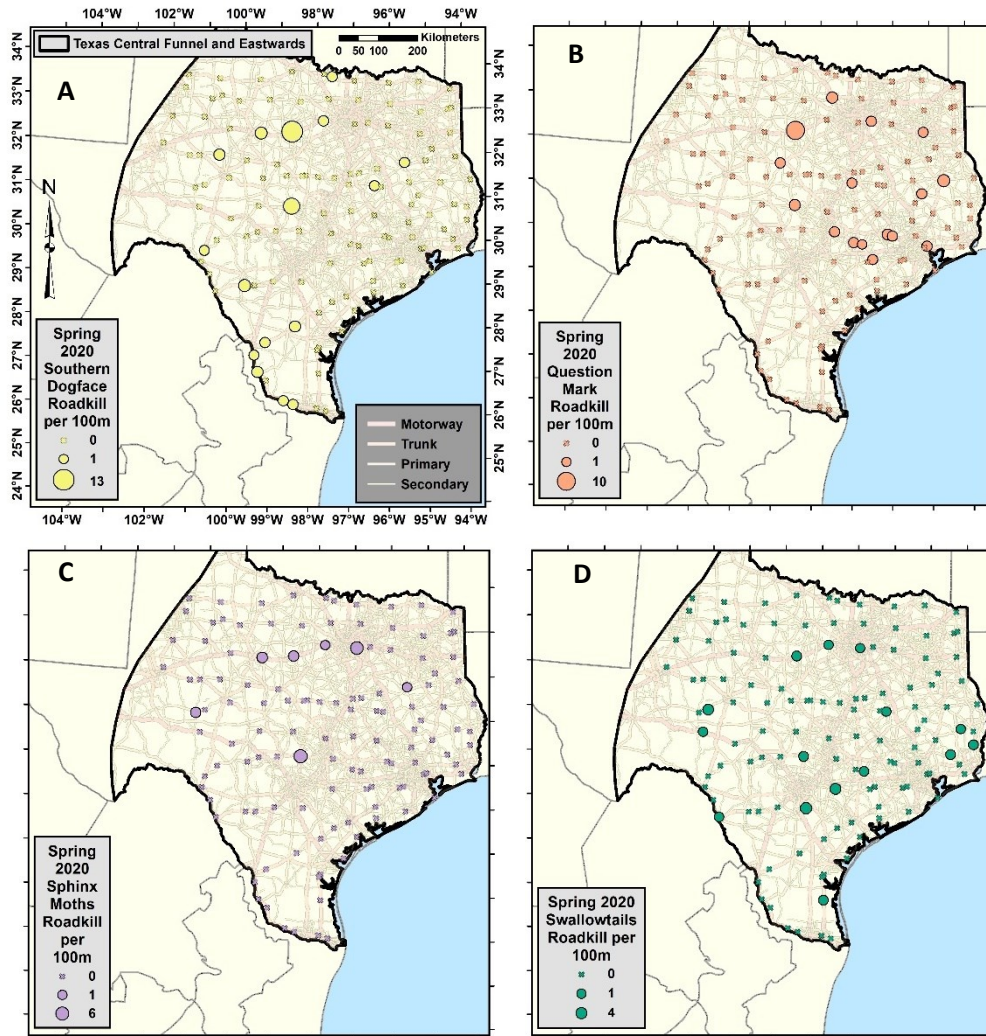
- Tracy J.L., and Coulson R.N. 2019. *Eastern Monarch Butterfly Fall Migratory Roadkill Distribution and Hotspot Regions within the Coastal and Central Migratory Funnels of Texas*. Texas A&M Department of Entomology/Texas Transportation Institute Project Final Report. TxDOT Environmental Affairs Division, Austin, Texas. 32 pp. Available at:  
[https://www.dropbox.com/s/an9wuzkyr54xdb0/TTI\\_TAMU%20Texas%20Monarch%20Roadkill%20Fall%202018%20Report.docx?dl=0](https://www.dropbox.com/s/an9wuzkyr54xdb0/TTI_TAMU%20Texas%20Monarch%20Roadkill%20Fall%202018%20Report.docx?dl=0)
- US Department of Agriculture NRCS. 2018. *Important Plants of the Monarch Butterfly, Southern Great Plains: Staff Guide*. Monarch butterflies plant lists: Southern plains; Kansas, Oklahoma, and Texas. 100 pp Available at:  
[https://www.nrcs.usda.gov/wps/PA\\_NRCSCconsumption/download?cid=nrcseprd772806&ext=pdf](https://www.nrcs.usda.gov/wps/PA_NRCSCconsumption/download?cid=nrcseprd772806&ext=pdf)
- US Department of Transportation, Federal Highway Administration (USDOT-FHWA). 2013. *Highway Functional Classification Concepts, Criteria and Procedures*. Accessed at:  
[https://www.fhwa.dot.gov/planning/processes/statewide/related/highway\\_functional\\_classifications/fcauab.pdf](https://www.fhwa.dot.gov/planning/processes/statewide/related/highway_functional_classifications/fcauab.pdf)
- USDOT-FHWA. 2020. *HPMS [Highway Monitoring Performance System] Public Release of Geospatial Data in Shapefile Format*. Polyline shapefiles for US states for 2017 including AADT and Traffic Speed. Accessed at:  
<https://www.fhwa.dot.gov/policyinformation/hpms/shapefiles.cfm>
- Vercayie, D. and Lambrechts, J. 2017. *Inventory and Evaluation of the Impact of Traffic on Wild Animals in Flanders*. Animals Under the Wheels 2.0, Final Report, Report Natuurpunt Study 2017/8, Mechelen, Belgium [In Dutch]. Accessed at:  
<https://omgeving.vlaanderen.be/sites/default/files/atoms/files/DierenonderdeWiel en Eindrapport 2017-min.pdf>

## Appendix

**Table A1. Correspondence of four highest Open Street Map road classes with nearby Federal Highway Administration (FHWA) road classes in Texas.**

FHWA Road Classification System (USDOT-FHWA 2013, 2020; SystemClass)	OSM Road Class (Geofabrik 2017; fClass) (Column Percent) [Row Percent]				Row Totals
	Motorway	Trunk	Primary	Secondary	
Unassigned	155 (11%) [7%]	50 (3%) [2%]	160 (6%) [8%]	1,738 (42%) [83%]	2,103
<b>Arterials</b>					
<i>Principal Arterials</i>					
<i>-Full Control</i>					
Interstate	873 (60%) [99%]	0 (0%) [0%]	5 (0%) [1%]	5 (0%) [1%]	883
Other Freeways and Expressways	374 (26%) [91%]	22 (1%) [5%]	1 (0%) [0%]	12 (0%) [3%]	409
<i>-Partial/Uncontrolled</i>					
Other Principal Arterials	40 (3%) [2%]	1,279 (83%) [53%]	932 (32%) [39%]	157 (4%) [7%]	2,408
<i>Minor Arterials</i>					
Minor Arterial	2 (0%) [0%]	170 (11%) [9%]	1,240 (43%) [65%]	496 (12%) [26%]	1,908
<b>Non-Arterials</b>					
<i>Collectors</i>					
Major Collector	4 (0%) [0%]	19 (1%) [1%]	539 (1%) [26%]	1,535 (37%) [73%]	2,097
Minor Collector	0 (0%) [0%]	2 (0%) [1%]	1 (0%) [1%]	187 (5%) [98%]	190
<i>Local</i>					
Local	0 (0%) [0%]	0 (0%) [0%]	0 (0%) [0%]	2 (0%) [100%]	2
Column Totals	1,448	1,542	2,878	4,132	

<sup>a</sup> Rasterized top four OSM road classes (30 m resolution) were matched with values of overlapping rasterized FHWA classes where possible. Where OSM road pixels did not overlap with FHWA roads, an algorithm was developed to match OSM road pixels with values of the nearest FHWA road class in a 3 x 3 cell neighborhood that did not differ by more than two hierarchical class levels (e.g., Primary could not be matched to Interstate as differ by more than two hierarchical class levels).



**Figure A1. Distribution of spring 2020 roadkill per 100m x 1m transect (unthinned) for various Lepidoptera taxa in Texas monarch migratory Central Funnel and eastwards: (A) Southern Dogface; (B) Question Mark; (C) Sphinx Moths; and (D) Swallowtails (symbols ca. proportional among taxa).**



## CHAPTER 4. FALL 2020 MONARCH AND ARTHROPOD ROADKILL AND ROADSIDE MILKWEEDS AND NECTAR PLANTS

### Summary

Fall 2020 monarch roadkill was estimated at 1.1 million for the monarch migratory Texas Central Funnel. This Texas monarch roadkill represented about 2.5% of the monarch overwintering population, similar to Texas roadkill representing 2.6% of the overwintering population in 2016 and 2018. Total fall 2020 arthropod roadkill of 19 million for Texas was higher than the 14.5 and 2 million roadkill estimated for spring 2020 and fall 2019, respectively. Pollinators (Lepidoptera and Hymenoptera) comprised 70-78% of all fall 2020 arthropod roadkill in the Texas Central and Coastal funnels. In both the fall of 2020 and 2019, monarchs were the dominant Lepidoptera roadkill for the Central Funnel, while pierids dominated Lepidoptera roadkill in the Coastal Funnel. Several species of migratory butterflies were abundant in fall 2020 roadkill that were rare or absent in fall 2019 roadkill, including American snout, large orange sulphur, southern dogface, and variegated fritillary. A weak but significant correlation was found between monarch roadkill and counts of both milkweed and non-milkweed monarch-preferred nectar plants. This correlation may not be causal, and it could have resulted from monarchs migrating through areas with higher milkweed and nectar plant populations in general. Dominant roadside milkweeds were antelopehorns and zizotes milkweed in the Central and Coastal Funnel respectively, followed by green antelopehorns. Both broadleaf and zizotes milkweeds were more abundant in the fall 2020 compared to spring 2020, and these milkweeds were the only species from which the few found roadside monarch larvae were reported. Milkweed populations were similar within 5 m of the road edge and from 5-10 m away from the road edge. Some milkweeds had greater stem length or stem numbers away from the road, indicating potentially more favorable growing conditions. The largest roadside milkweed hotspots were mostly of antelopehorns and green antelopehorns in the northeastern portion of the Central Funnel. The most abundant roadside monarch-preferred nectar plants were Engelmann daisy, Spanish gold, green antelopehorn, heath aster, antelopehorns, and zexmenia in the Central Funnel. In the Coastal Funnel, the dominant nectar plants were camphor daisy, seaside goldenrod, climbing milkweed vine, and Texas vervain. These data can guide conservation strategies for reducing monarch and pollinator roadkill and using roadside habitats to support monarch and pollinator populations.

## Methods

Fall 2020 arthropod roadkill and roadside monarch-preferred nectar plant observations along roadside transects were made by a two-person team following a similar protocol as used in the spring (Part II Chapter 3). Transects were spaced more closely than in the spring in order to concentrate more observations within the monarch Central and Coastal funnel migration pathways (Fig. 1). Transects were divided into three types related to their spacing and selection: (1) **random dispersed transects** every 80 km (50 mi) for assessing milkweed plant densities only (no roadkill; used for first time in this study); (2) **dispersed transects** every 25-50 km (average 38 km; 15-31mi, average 23 mi) that are ideally placed in areas where spotting milkweed, but not more than 50 km distant, used for assessing roadkill, roadside vegetation, and monarch larvae; (3) **adventitious transects** are transects made when time allows within large patches of milkweeds that are spotted between the dispersed transects, used for same purpose as dispersed transects. Transects were not placed within urban centers and the transect spacing did not include distance through urban areas. Dispersed and adventitious transects were established by roadside milkweed stands, where feasible, in order to obtain information on monarch larval abundance on roadside milkweeds and relative abundance of roadside milkweed species. The random dispersed transects were designed to provide an unbiased assessment of overall roadside milkweed density. A designated spotter located potential transect sites among roadside milkweed stands. The location of each transect was recorded as either the North, South, East, or West side of the road, depending on the orientation of the road. Around once a day, as time allowed, an additional *across road transect* was established on the opposite side of the road of a milkweed stand in order to look for patterns across roadway sides. Roadkill transects were counted over the four major Open Street Map road classes (Geofabrik 2017), which encompass the four main Federal Highway Administration (FHWA) road classes (USDOT-FHWA 2013, 2020), throughout the Texas portions of the monarch migratory Central and Coastal funnels (Fig. 1, Table 1). Observations were made over five weekly trips about every other week from 12 October to 11 December, 2020.

Three overlapping roadside data transects were employed: (1) **100 m x 1 m roadkill transects** for collecting data on roadkill of monarchs, other arthropods, and vertebrates; (2) **two 100 m x 5 m roadside vegetation transects** (both inner and outer) for collecting counts of milkweeds, monarch-preferred nectar plants, and monarch larvae; and (3) **50 m x 5 m plant percent cover transect** in the center of the inner 100 m x 5 m roadside vegetation transect for obtaining percent cover of dominant vegetation, milkweeds, and monarch-preferred nectar plants (Figs. 2-4). The outer 100 x 5 m roadside vegetation transect was added in this study to allow comparison between roadside plants adjacent to and away from the road edge. Field assistants followed

safety protocols given in Part II Chapter 3. Additional details on transect data collection are found in Part II Chapter 3.

Counts of roadkill and area of monarch-preferred nectar plants were extrapolated over total lengths of major OSM roadways (fclasses 1-4) in the study area. Potential differences in densities of arthropod roadkill and milkweed plants per 100 meters and nectar plant percent cover in 50 m x 5 m transects were tested among OSM road classes using the non-parametric Kruskal-Wallis test. Roadkill estimates, milkweed numbers, and the area of monarch preferred nectar plants were extrapolated across the Texas Central Funnel and eastwards by multiplying numbers per km or areas from dispersed random transects with lengths of roadway or roadside area (e.g., McKenna et al. 2001, Kantola et al. 2019). Pairwise correlations by locations for roadkill per 100 m among selected arthropod taxa and arthropods with milkweed plant counts were tested using the Spearman rank order correlation ( $r_s$ ), with Holm's correction for multiple comparisons using the *r* psych package (for Excel spreadsheets and Google Earth kml files of fall 2020 roadkill and roadside data and Excel spreadsheets with charts, see [https://drive.google.com/drive/folders/1cOB6sY4LfpSdl3JZS\\_MExlCBk\\_Faq2mU?usp=sharing](https://drive.google.com/drive/folders/1cOB6sY4LfpSdl3JZS_MExlCBk_Faq2mU?usp=sharing) )

## Results and Discussion

### *Arthropod Roadkill*

Similar to the spring 2020 study, estimated arthropod roadkill per transect was not significantly different among the four examined road classes (Table 1). Consequently, data are pooled among highway types for comparisons and for estimating total roadkill. Fall 2020 arthropod roadkill was dominated by Lepidoptera in both the Central and Coastal funnels, similar to results from fall 2019 (Table 2, Fig. 5). We observed greater Lepidoptera roadkill than seen in previous studies from other regions (Fig. 5F; see also Part III Chapter 2, Fig. 10). Total Texas fall 2020 arthropod roadkill totaled over 19 million (Table 2) and was higher compared to that of spring 2020, which totaled 14 million (Part II Chapter 3), and much higher than the 2 million for fall 2019 (Tracy et al. 2020a). Greater Orthoptera and Odonata roadkill were seen in the fall of 2020 compared to spring 2020 for the Central and Coastal funnels, respectively (Fig. 5). Monarchs comprised the greatest proportion of roadkill in the Central Funnel in both fall 2020 and 2019, but monarch roadkill was less than that of certain pierids in the Coastal Funnel for both fall 2020 and 2019 (Table 2, Fig. 6).

In the Central Funnel, monarch roadkill was significantly moderately correlated with that of orange sulphur roadkill, significantly weakly correlated with southern dogface roadkill, and not significantly correlated with large orange sulphur or American snout

roadkill (Table 3, Fig. 7). Monarch roadkill was significantly weakly correlated with milkweed and non-milkweed roadside nectar plant counts in the Central Funnel (Table 3, Fig. 7). These weak significant correlations between monarch roadkill and roadside nectar plants do not indicate causation. The weak correlations may be the result of an overall higher population of migrating monarchs in areas with higher milkweed and nectar plant populations in both roadside and non-roadside habitats.

Uncollected November 9 monarch roadkill observations at four transects within the Lavaca Bay Causeway hotspot zone were on average 7% lower than roadkill collected 13 days later on 22 November (Table 4). The monarch roadkill either persisted for the 13 days, or new roadkill replaced any lost roadkill. Further study with marked roadkill is needed to determine which was the case.

Several butterflies dominated fall 2020 roadkill that were not present or common in fall 2019 roadkill, including large orange sulphur, southern dogface, variegated fritillary, and American snout (Figs. 6, 8). All of these species are migratory (Scott 1992), as are many of the other butterflies dominating fall Texas Lepidoptera roadkill (see Part III Chapter 2). Variegated fritillary and orange sulphur were common in both spring 2020 and Central Funnel fall 2020 roadkill (Fig. 6), but generally the dominant butterfly roadkill species differed. The gulf fritillary, which was common in fall 2019 Central Funnel and Gainesville, Florida roadkill, was much less common in fall 2020 Texas Central Funnel roadkill (Fig. 6). Queen roadkill was common in the Coastal Funnel for both fall 2020 and 2019. Hymenoptera roadkill were dominated by wasps in both fall 2020 and spring 2020, and native bees were less abundant in fall compared to spring roadkill (Table 2, Fig. 9). A significant weak correlation was found between native bee roadkill and roadside milkweed counts (Table A1, Fig. A3).

The largest arthropod roadkill hotspots were in the southern portions of the Central and Coastal funnel, and they were dominated by Lepidoptera (Fig. 10). Coleoptera were prominent in one hotspot south of Sarita, Texas in the southern Coastal Funnel (Figs. 10C, 4A). Orthoptera dominated some northern Central Funnel hotspots (Fig. 10E). Maximum roadkill densities in hotspots of several butterflies were larger than that of monarchs, including for American snout, orange sulphur, and southern dogface (Figs. 11-12). Roadkill hotspots for Hymenoptera were dominated mostly by wasps, and they were largest in the northern Central Funnel. The largest native bee roadkill hotspots were in the Coastal Funnel (Fig. 13).

The great majority of monarch roadkill hotspots and hotspot zones were found in the same two Hotspot Regions as in previous years (Part III Chapter 3): (1) the Central Funnel Junction-Sheffield-Eagle Pass Monarch Roadkill Hotspot Region; and (2) the Coastal Funnel Point Comfort/Corpus Christi Causeways Monarch Roadkill Hotspot Region (Fig. 11C). As observed in the fall of 2016 (Part III Chapter 3), many of the Central



Funnel monarch roadkill hotspots were in close proximity to draws, such as in the Howard/Eureka Draw Hotspot Zone and Sonora Hotspot Zone, which included the Granger Draw Hotspot (Fig. 14). Additional transects at the Threemile Draw Hotspot north of Sanderson probably would have revealed another hotspot zone. The Coastal Funnel hotspots were restricted to causeways, in particular the Lavaca Bay Causeway Hotspot Zone and the Lyndon B Johnson Causeway Hotspot Zone (Fig. 15). Multiple transects at two primary hotspot zones (average transect counts greater than 12) per funnel yielded 17,898 and 1,651 monarch roadkill in the Central and Coastal funnels, respectively (Table 4).

Fall 2020 monarch roadkill was estimated at 1.1 and 0.5 million in the Texas Central and Coastal funnels, respectively (Table 2). Fall 2020 roadkill in the Texas Central Funnel represented about 2.5% of the overwintering monarch population, which was very similar to the 2.6% observed in 2016 and 2018. The fall 2017 and 2019 Texas Central Funnel roadkill represented only 0.9% and 0.7% of the monarch overwintering population. These results revealed five year pattern of alternating even numbered years of higher roadkill and odd numbered years of lower roadkill in relation to the overwintering population from 2016 to 2020 (Table 5). A corresponding pattern was seen in the fall monarch roadkill for the Texas Coastal Funnel, with roadkill at 0.1-0.2% of the overwintering population in 2018 and 2020, and only 0.06% of the overwintering population in 2019 (Table 5). The proportion of fall 2020 Texas Central Funnel monarch roadkill occurring in hotspot zones, 1.64%, was higher than seen from 2017-2019, but lower than the 6.15% seen in fall 2016 (Table 5). The 3% of Texas Coastal Funnel roadkill occurring in hotspots was similar to that seen in 2018 (Table 5).

### *Roadside Milkweeds*

Numbers of fall 2020 roadside milkweed plants per transect did not significantly differ among road classes and were pooled for comparisons and extrapolations (Table 1). Numbers of milkweed plants per transect type also did not significantly differ for milkweeds, but did differ for non-milkweeds (Table 6). Significantly more antelopehorns occurred in the Central Funnel compared to the Coastal Funnel (Table 7). We found no significant difference in the number of milkweeds counted within 5 m of the road edge versus 5-10 m away from the road edge. Green antelopehorn had higher stem counts and zizotes milkweed had longer stems away from the road edge (Table 7). Greater milkweed stem numbers and length away from the road edge may reflect potentially more favorable higher soil depth or moisture conditions.

Fall roadside milkweeds were dominated by antelopehorns in the Central Funnel and zizotes milkweed in the Coastal Funnel (Fig. 16). In contrast, green antelopehorns dominated spring 2020 roadsides. Green antelopehorns had a higher proportion of

stems compared to plants in the fall of 2020 and antelopehorns had a higher proportion of stems compared to plants in the spring of 2020 (Fig. 16). Also, antelopehorns had higher stems per plant in the spring compared to green antelopehorns (Part II Chapter 3), and green antelopehorns tended to have higher stems per plant than antelopehorns in the fall when away from the road (Table 7). Broadleaf and zizotes milkweeds were relatively more abundant, and green antelopehorns were less abundant in the fall of 2020 compared to the spring of 2020 (Table 7). In addition, zizotes and broadleaf milkweed plant counts per transect tended to be higher in fall 2020 (Table 7) compared to spring 2020 (Table 4 of Part II Chapter 3). Roadside counts of antelopehorns and green antelopehorns were similar between spring and fall. Slim milkweed was found in one roadside transect northeast of Decatur, Texas (Fig. 17).

Roadside milkweed hotspots were largest and most concentrated in the northeastern portion of the Central Funnel, and were dominated by antelopehorns and green antelopehorns. The largest broadleaf and zizotes milkweed hotspots were seen in the western Central Funnel and southern Coastal Funnel, respectively (Fig. 18).

### *Roadside Monarch Preferred Nectar Plants*

Percent cover for roadside monarch preferred nectar plant species within the 50 m x 5 m portions of transects did not significantly differ with road class (Table 1), and data were pooled across road classes for analysis (Tables 6, 8). Plant counts per 100 x 10 m transects did not differ among Dispersed and Adventitious transects among pooled non-milkweed nectar plants (Table 6). Seventeen and six species of monarch-preferred nectar plants were found in the Central and Coastal funnels, respectively (Table 8, Fig. 19). We estimated a total of 6,458 hectares of fall 2020 monarch preferred roadside nectar plants over both funnels (Table 8). The most abundant fall 2020 nectar plants in the Central Funnel in terms of both percent cover and plant counts included Englemann daisy, Spanish gold, green antelopehorn, heath aster, antelopehorns, and zexmenia (Fig. 20A,D). Dominant nectar plants in the Coastal funnel included camphor daisy, seaside goldenrod, climbing milkweed vine, and Texas vervain (Fig. 20B,E). Englemann daisy, Texas vervain, and climbing milkweed vine were also common spring 2020 roadside monarch-preferred nectar plants (Fig. 20C). Monarch-preferred nectar plant hotspots occurred for Englemann daisy in the central and southern Central Funnel, heath aster in the northern Central and Coastal funnels, Spanish gold in the western Central Funnel, Texas vervain in the northern Coastal Funnel, seaside goldenrod in the northern Coastal Funnel, and climbing milkweed vine in the southern Coastal Funnel (Fig. 21).

### *Roadside Monarchs*

Fifth instar monarch larvae were found in only two fall 2020 transects, one dead larva on broadleaf milkweed in the Central Funnel and four live larvae on zizotes milkweed in the

Coastal Funnel (Table 9; Fig. 22A). In contrast, 14 transects had monarch larvae in the spring 2020 survey (Fig. 22B) on four different species of milkweed. Further analysis of previous fall observation data from 2019 and 2018 is planned for comparison.

## Conclusion

Texas fall 2020 arthropod roadkill was estimated at over 19 million, including over 1 million monarch roadkill, representing 2.5% of the Mexican overwintering monarch population. Similarly, 2.6% of the Mexican overwintering population was lost to roadkill in the Texas Central Funnel in 2016 and 2018, establishing a pattern of higher monarch roadkill every other even numbered year. A similar pattern of higher roadkill representing from 0.1-0.2% of the overwintering population was seen in 2018 and 2020 for the Texas Coastal Funnel. Monarchs comprised the greatest portion of Central Funnel roadkill in both fall 2020 and fall 2019. As observed in some prior years, monarch hotspots in the Central Funnel were often associated with draws, and Coastal Funnel hotspots were restricted to causeways. Further analysis of the correlation between monarch primary and superhotspots with NHDPlus stream flowlines is planned. Several species of migratory butterflies dominated fall 2020 roadkill that were rare or absent in fall 2019 roadkill, including American snouts, southern dogface, large orange sulphur, and variegated fritillary. Monarch roadkill was significantly weakly correlated with counts of roadside milkweeds and nectar plants, but the relationship is not necessarily causal.

The same four species of milkweeds were the most common in both fall and spring of 2020, including antelopehorns, green antelopehorn, zizotes milkweed, and broadleaf milkweed. Zizotes and broadleaf milkweeds were more abundant in the fall than the spring. Dominant roadside monarch-preferred nectar plants included Engelmann daisy, green antelopehorn, heath aster, antelopehorns, zexmenia, camphor daisy, seaside goldenrod, Texas vervain, and climbing milkweed vine. Three species were also common along spring 2020 roadsides, Englemann daisy, Texas vervain, and climbing milkweed vine. Plant counts for milkweed and non-milkweed nectar plants did not differ between transect types, but random dispersed transects should be maintained to examine and reduce sample bias. In addition, we plan to include non-milkweed monarch-preferred nectar plants with milkweeds in the spring random dispersed transect counts. Only two roadside transects had fall 2020 monarch larvae, and these were on broadleaf and zizotes milkweeds.

These data can be used to better understand the annual variability in the distribution and density of monarch and pollinator roadkill and roadside nectar and host plant resources in order to guide more effective conservation strategies for reducing roadkill and using roadside habitats to support monarch and other pollinator populations.

## Tables

**Table 1. Arthropod roadkill, nectar plant counts, percent cover of nectar plants, and kilometer roadway length by Open Street Map (OSM) road classes (with corresponding Federal Highway Administration, FHWA, road classifications) for Oct-Dec 2020 in Texas for monarch migratory Central and Coastal funnels.**

Unit	Estimates per Transect (Mean ± SD) <sup>a</sup>				Overall
	Motorway (60% Interstate; 26% Other Freeways and Expressways)	Trunk (83% Other Principal Arterials; 11% Minor Arterials)	Primary (43% Minor Arterials; 32% Other Principal Arterials)	Secondary (37% Major Collectors; 12% Minor Arterials;)	
<i>Arthropod Roadkill</i> (100m x 1m transects, unthinned data) <sup>a</sup>					
Central	33.51 ± 48.04	31.81 ± 22.98	31.35 ± 44.11	16.57 ± 15.91	30.56 ± 40.25
Funnel	(29)a	(20)a	(55)a	(11)a	(115)
Coastal	6.83 ± 8.27	37.85 ± 60.02	9.5 ± 11.08	62.98 ± 110.38	24.41 ± 53.14
Funnel	(8)a	(17)a	(24)a	(7)a	(56)a
<i>Milkweed Plant Counts</i> (100m x 5m transects) <sup>b</sup>					
Central	9.19 ± 16.20				
Funnel	(26)a	6.36 ± 7.13 (14)a	13.97 ± 19.1 (31)a	12.25 ± 8.58 (4)a	10.8 ± 16.05 (75)
Coastal					
Funnel	15.00 ± 0.00 (1)	6.00 ± 6.78 (6)a	10.57 ± 15.5 (7)a	1.00 ± 0.00 (1)	8.4 ± 11.46 (15)
<i>Other Nectar Plant Counts</i> (100m x 5 m transects) <sup>c</sup>					
Central	72.34 ± 94.65	48.35 ± 68.24	32.29 ± 53.58	62.91 ± 68.44	48.11 ± 70.98
Funnel	(29)a	(20)a	(55)a	(11)a	(115)
Coastal			33.54 ± 79.31	135.14 ± 293.75	59.72 ± 150.92
Funnel	42 ± 65.58 (9)a	75 ± 179.52 (17)a	(24)a	(7)a	(57)
<i>Milkweed Percent Cover</i> (50m x 1m transects) <sup>c</sup>					
Central					
Funnel	0.07 ± 0.37 (29)a	0.3 ± 0.57 (20)a	0.09 ± 0.29 (55)a	0.18 ± 0.4 (11)a	0.13 ± 0.39 (115)
Coastal					
Funnel	0.00 ± 0.00 (9)	0.00 ± 0.00 (17)	0.00 ± 0.00 (24)	0.00 ± 0.00 (7)	0.00 ± 0.00 (57)
<i>Other Nectar Plant Percent Cover</i> (50m x 1m transects) <sup>c</sup>					
Central					
Funnel	0.41 ± 0.87 (29)a	0.2 ± 0.41 (20)a	0.45 ± 0.86 (55)a	1.36 ± 1.75 (11)a	0.49 ± 0.96 (115)
Coastal					
Funnel	0.44 ± 0.88 (9)a	0.41 ± 0.71 (17)a	1.71 ± 6.14 (24)a	1.57 ± 3.74 (7)a	1.11 ± 4.20 (57)
<b>Open Street Map Motorway/Trunk/Primary/Secondary Roadway Lengths (km)</b>					
<b>Central Funnel</b>					
Texas	4,844	6,413	14,309	19,661	45,227
Entire	9,293	10,538	26,366	39,105	85,302
<b>Coastal Funnel</b>					
Texas	2,004	3,299	5,456	11,120	21,879
Entire	4,043	5,466	10,705	26,917	47,131

<sup>a</sup>Means in the same row with the same letter are not significantly different (P < 0.05; Pairwise Wilcoxon test with Holm's correction for P-value, preceded by Kruskal-Wallis test) (For further details on correspondence of OSM and FHWA road classes, see Part II Chapter 3, Table A1).

<sup>b</sup>From all transects (dispersed, adventitious, and random dispersed).



---

**Table 1. Arthropod roadkill, nectar plant counts, percent cover of nectar plants, and kilometer roadway length by Open Street Map (OSM) road classes (with corresponding Federal Highway Administration, FHWA, road classifications) for Oct-Dec 2020 in Texas for monarch migratory Central and Coastal funnels.**

---

<sup>c</sup>From dispersed and adventitious transects.

**Table 2. Arthropod 100 x 1 m roadkill transect counts (includes extrapolations to uncounted sides) by various taxa for fall 2020 in monarch fall migratory Central and Coastal funnels of Texas for 100m transects spatially thinned to 10 km.<sup>a</sup>**

Taxa/Species	Roadkill Counts (Percent of Taxa) – Sum from Thinned Transects		Roadkill per 100 m Transect (Mean ± SD) <sup>b</sup>		Estimated Total Roadkill = (Estimated Roadkill per 100 m x 10) * Km Length Highways <sup>c</sup>			
	Central Funnel	Coastal Funnel	Central Funnel (n = 107)	Coastal Funnel (n = 43)	Central Funnel	Coastal Funnel	Texas Central Funnel	Texas Coastal Funnel
<i>Arthropods</i>	3115 (72%)	1207 (28%)	29.11 ± 39.75a	28.08 ± 59.85a	24,832,130	13,234,714	13,165,960	6,143,776
Lepidoptera	2233 (72%)	800 (66%)	20.86 ± 38.25a	18.61 ± 48.92a	17,797,904	8,772,833	9,436,423	4,072,496
Orthoptera	385 (12%)	9 (1%)	3.6 ± 8.98a	0.21 ± 0.59b	3,067,683	98,756	1,626,481	45,844
Coleoptera	146 (5%)	130 (11%)	1.37 ± 3.43a	3.02 ± 14.81a	1,165,767	1,425,548	618,088	661,763
Hymenoptera	192 (6%)	49 (4%)	1.79 ± 3.5a	1.15 ± 1.78a	1,531,131	540,362	811,804	250,845
Odonata	150 (5%)	215 (18%)	1.4 ± 3.92a	5.01 ± 8.3a	1,192,474	2,360,605	632,248	1,095,833
Hemiptera	10 (0%)	3 (0%)	0.09 ± 0.38	0.08 ± 0.36	77,170	36,609	40,916	16,994
<i>Lepidoptera Taxa</i>								
<i>Nymphalidae</i>	1116 (43%)	320 (33%)	10.43 ± 16.05a	7.44 ± 16.86a	8,894,288	3,504,464	4,715,739	1,626,831
American Snout ( <i>Libytheana carinenta</i> )	424 (19%)	124 (15%)	3.96 ± 10.81a	2.88 ± 10.59a	3,379,554	1,355,181	1,791,835	629,098
Monarch ( <i>Danaus plexippus</i> )	257 (12%)	9 (1%)	2.41 ± 6.44a	0.21 ± 0.62a	2,052,430	100,290	1,088,195	46,556
Variegated Fritillary ( <i>Euptoieta claudia</i> )	165 (7%)	9 (1%)	1.54 ± 4.98a	0.2 ± 0.73a	1,313,172	95,577	696,242	44,369
Queen ( <i>Danaus gilippus</i> )	109 (5%)	74 (9%)	1.02 ± 1.4a	1.73 ± 3.22a	871,834	813,065	462,245	377,438
Painted Lady ( <i>Vanessa cardui</i> )	48 (2%)	0 (0%)	0.44 ± 1.59a	0.00 ± 0.00b	378,837	-	200,859	-
Gulf Fritillary ( <i>Agraulis vanillae</i> )	58 (3%)	58 (7%)	0.54 ± 1.15a	1.36 ± 2.59a	461,906	638,789	244,902	296,537
Goatweed Butterfly ( <i>Anaea andria</i> )	28 (1%)	36 (4%)	0.26 ± 0.68a	0.83 ± 1.61a	222,901	389,105	118,182	180,629
Red Admiral ( <i>Vanessa atalanta</i> )	11 (0%)	1 (0%)	0.1 ± 0.42	0.03 ± 0.18	85,461	12,934	45,312	6,004
Buckeye ( <i>Junonia coenia</i> )	12 (1%)	8 (1%)	0.11 ± 0.49	0.18 ± 0.54	94,869	86,590	50,299	40,196
Viceroy ( <i>Limenitis archippus</i> )	2 (0%)	1 (0%)	0.02 ± 0.15	0.03 ± 0.18	17,379	12,934	9,214	6,004
Hackberry Emperor ( <i>Asterocampus celtis</i> )	2 (0%)	0 (0%)	0.02 ± 0.19	0.00 ± 0.00	15,944	-	8,454	-
<i>Pieridae</i>	1116 (43%)	320 (33%)	10.43 ± 16.05a	7.44 ± 16.86a	8,894,288	3,504,464	4,715,739	1,626,831
Orange Sulphur ( <i>Colias eurytheme</i> )	407 (18%)	4 (0%)	3.81 ± 9.83a	0.08 ± 0.4b	3,247,216	38,801	1,721,669	18,012
Large Orange Sulphur ( <i>Phoebis agarithe</i> )	359 (16%)	231 (29%)	3.36 ± 16.43a	5.36 ± 17.07a	2,863,277	2,528,195	1,518,106	1,173,630
Southern Dogface ( <i>Zerene cesonia</i> )	270 (12%)	205 (26%)	2.53 ± 7.65a	4.77 ± 19.27a	2,155,510	2,246,505	1,142,848	1,042,865

**Table 2. Arthropod 100 x 1 m roadkill transect counts (includes extrapolations to uncounted sides) by various taxa for fall 2020 in monarch fall migratory Central and Coastal funnels of Texas for 100m transects spatially thinned to 10 km.<sup>a</sup>**

Taxa/Species	Roadkill Counts (Percent of Taxa) – Sum from Thinned Transects		Roadkill per 100 m Transect (Mean ± SD) <sup>b</sup>		Estimated Total Roadkill = (Estimated Roadkill per 100 m x 10) * Km Length Highways <sup>c</sup>			
	Central Funnel	Coastal Funnel	Central Funnel (n = 107)	Coastal Funnel (n = 43)	Central Funnel	Coastal Funnel	Texas Central Funnel	Texas Coastal Funnel

**Table 2 (cont.). Arthropod 100 x 1 m roadkill transect counts roadkill counts (includes extrapolations to uncounted sides) by various taxa for fall 2020 in monarch fall migratory Central and Coastal funnels of Texas for 100m transects spatially thinned to 10 km.<sup>a</sup>**

Taxa/Species	Roadkill Counts (Percent of Taxa) – Sum from Thinned Transects		Roadkill per 100 m Transect (Mean ± SD) <sup>b</sup>		Estimated Total Roadkill = (Estimated Roadkill per 100 m x 10) * Km Length Highways <sup>c</sup>			
	Central Funnel	Coastal Funnel	Central Funnel (n = 107)	Coastal Funnel (n = 43)	Central Funnel	Coastal Funnel	Texas Central Funnel	Texas Coastal Funnel
	<i>Pieridae</i> (cont.)							
Clouded Sulphur ( <i>Colias philodice</i> )	13 (1%)	3 (0%)	0.12 ± 0.69	0.07 ± 0.35	103,479	34,855	54,864	16,180
Dainty Sulphur ( <i>Nathalis iole</i> )	5 (0%)	0 (0%)	0.04 ± 0.46	0.00 ± 0.00	37,629	-	19,951	-
Little Yellow ( <i>Pyrisitia lisa</i> )	2 (0%)	11 (1%)	0.02 ± 0.16	0.27 ± 0.65	18,814	125,390	9,975	58,208
Lyside Sulphurs ( <i>Kricogonia lyside</i> )	1 (0%)	5 (1%)	0.01 ± 0.1	0.11 ± 0.43	7,972	51,734	4,227	24,016
Sleepy Orange ( <i>Abaeis nicippe</i> )	1 (0%)	0 (0%)	0.01 ± 0.11	0.00 ± 0.00	9,407	-	4,988	-
Cloudless Sulphur ( <i>Phoebis sennae</i> )	0 (0%)	9 (1%)	0.00 ± 0.00	0.2 ± 0.78	-	95,577	-	44,369
Colias Sulphur ( <i>Colias</i> sp.)	0 (0%)	1 (0%)	0.00 ± 0.00	0.03 ± 0.18	-	12,934	-	6,004
Other Pieridae	0 (0%)	5 (1%)	0.00 ± 0.00	0.12 ± 0.63	-	56,776	-	26,357
<i>Papilionidae</i> (Swallowtails)	20 (1%)	2 (0%)	0.18 ± 0.54a	0.05 ± 0.36a	157,051	25,867	83,268	12,008
Pipevine Swallowtail ( <i>Battus philenor</i> )	17 (1%)	1 (0%)	0.16 ± 0.52	0.03 ± 0.18	138,237	12,934	73,293	6,004
Black Swallowtail ( <i>Papilio polyxenes</i> )	1 (0%)	0 (0%)	0.01 ± 0.11	0.00 ± 0.00	9,407	-	4,988	-
Other Swallowtails ( <i>Papilio</i> sp.)	1 (0%)	1 (0%)	0.01 ± 0.11	0.03 ± 0.18	9,407	12,934	4,988	6,004
<i>Lycaenidae</i> (Blues)	2 (0%)	2 (0%)	0.02 ± 0.16a	0.05 ± 0.25a	18,814	25,867	9,975	12,008
Reakirt's Blue ( <i>Echinargus isola</i> )	0 (0%)	1 (0%)	0.00 ± 0.00	0.03 ± 0.18	-	12,934	-	6,004
Hairstreaks (Theclinae)	2 (0%)	1 (0%)	0.02 ± 0.16	0.03 ± 0.18	18,814	12,934	9,975	6,004

**Table 2. Arthropod 100 x 1 m roadkill transect counts (includes extrapolations to uncounted sides) by various taxa for fall 2020 in monarch fall migratory Central and Coastal funnels of Texas for 100m transects spatially thinned to 10 km.<sup>a</sup>**

Taxa/Species	Roadkill Counts (Percent of Taxa) – Sum from Thinned Transects		Roadkill per 100 m Transect (Mean ± SD) <sup>b</sup>		Estimated Total Roadkill = (Estimated Roadkill per 100 m x 10) * Km Length Highways <sup>c</sup>			
	Central Funnel	Coastal Funnel	Central Funnel (n = 107)	Coastal Funnel (n = 43)	Central Funnel	Coastal Funnel	Texas Central Funnel	Texas Coastal Funnel
	<i>Other Heterocera (Moths)</i>	22 (1%)	0 (0%)	0.2 ± 1.39	0.00 ± 0.00	174,431	-	92,483
<i>Hesperiidae (Skippers)</i>	14 (1%)	1 (0%)	0.13 ± 0.64	0.03 ± 0.18	110,016	12,934	58,330	6,004
<i>Sphingidae (Sphinx Moths)</i>	0 (0%)	1 (0%)	0.00 ± 0.00	0.03 ± 0.18	-	12,934	-	6,004
<i>Hymenoptera Taxa</i>								
Honey Bee ( <i>Apis mellifera</i> )	11 (6%)	1 (2%)	0.1 ± 0.71a	0.03 ± 0.18a	84,664	12,934	44,889	6,004
Native Bees	16 (8%)	8 (17%)	0.15 ± 0.47a	0.19 ± 0.81a	128,830	90,535	68,305	42,028
Wasps	165 (86%)	40 (81%)	1.54 ± 2.97a	0.93 ± 1.29a	1,317,637	436,893	698,609	202,813

<sup>a</sup>Adventitious transects within prior monarch roadkill hotspot areas also removed. See text for ratios used to extrapolate roadkill counts on unsampled side of road.

<sup>b</sup>Paired mean roadkill counts for a given butterfly taxon for either single or both roadsides with the same letter are not significantly different ( $P < 0.05$ ; Welch's t-test with Bonferroni correction for multiple comparisons). Bonferroni correction was applied across various groups of taxa: (1) all taxa above family level (orders and phylum); (2) Lepidoptera family level taxa; (3) Hymenoptera group level taxa; and (4) selected Lepidoptera species taxa with occurrences of at least 6% in one funnel.

<sup>c</sup>Length of highways from Table 1.



**Table 3. Lepidoptera roadkill spatial correlations ( $r_s$ ) for fall 2020 in monarch fall migratory Central and Coastal funnels of Texas for 100m transects (unthinned data).<sup>a</sup>**

Species Roadkill	Central Funnel (n = 115)	Coastal Funnel (n = 55)
<i>Correlation with Monarch Roadkill<sup>b</sup></i>		
American Snout	0.10	-0.14
Queen	--	-0.02
Orange Sulphur	0.43*	--
Large Orange Sulphur	0.05	-0.01
Southern Dogface	0.24*	-0.17
<i>Correlation with Milkweed Plant Count in 100 x 10 m transects<sup>c</sup></i>		
Monarch	0.23*	0.11
Other Lepidoptera	0.07	-0.01
<i>Correlation with Non-Milkweed Nectar Plant Count in 100 x 10 m transects<sup>b</sup></i>		
Monarch	0.24*	0.08
Other Lepidoptera	-0.06	-0.04

<sup>a</sup>Asterisks indicate significant correlation ( $P < 0.05$ ; paired Spearman rank order correlations with Holm’s correction for multiple comparisons per migratory funnel and correlation group subheading) (See Figure 7 for graphs of significant correlations; see Table A1 and Fig. A3 for other correlations).

<sup>b</sup>Includes dispersed and adventitious transects.

<sup>c</sup>Includes dispersed, adventitious, and random dispersed transects.

**Table 4. Monarch roadkill persistence at SH-35 Lavaca Bay Causeway, peninsula west of Point Comfort, Texas in November 2020.**

Date	Number Roadkill Monarchs (Raw Total) per ESCT Transects				Mean ± SD
	1	2	3	4	
9 November 2020 (uncollected)	1	7	10	25	10.75 ± 10
22 November 2020 (collected)	0	6	14	26	11.5 ± 11
<i>Difference (13 days)</i>	-1	-1	4	1	0.75 ± 2
<i>% Difference</i>					7% ± 22%

**Table 5. Monarch roadkill counts and total estimates for primary hotspot zones in the Texas portions of the Central and Coastal funnels for the fall of 2020.<sup>a</sup>**

Location	Roadkill per 100 m Transect Mean ± SD (n) [range]	Length (km) <sup>b</sup>	Estimated Total Roadkill = (Estimated Roadkill per 100 m x 10) * Km Length Highways
<i>Fall 2020 Central Funnel Primary Hotspot Zones</i>			
Howard/Eureka Draw Hotspot Zone, IH-10	39.33 ± 3.06 (3) [36-42]	19	7,473
Sonora Hotspot Zone, 29 km east to 24 km west	19.67 ± 7.51		
Sonora along IH-10	(3) [12-20]	53	10,425
<b>Total</b>			<b>17,898</b>
<i>Fall 2020 Coastal Funnel Primary Hotspot Zones</i>			
Lavaca Bay Causeway Hotspot Zone, SH-35	23.93 ± 20.99 (4) [7.15-52]	5	1,197
Lyndon B Johnson Causeway Hotspot Zone, SH-35	11.95 ± 8.62 (3) [2.86-20]	3.8	454
<b>Total</b>			<b>1,651</b>

<sup>a</sup>Primary hotspot zones have an average of at least 12 roadkill per 100 m (Part III Chapter 3) over their entire length.

<sup>b</sup>Lengths of highways from Figs. 13-14.

**Table 5. Estimated fall monarch roadkill over portions of migratory funnels in relation to overwintering estimates.**

Year/ Locati on	Average Thinned Presence/ Absence Roadkill per 100m <sup>a</sup>	Estimated Roadkill			Hotspot Zone Roadkill as Percent of Total for Texas	Area Monarchs Over- wintering in Mexico (Ha) (Monarch Watch 2021)	Estimated Over- wintering (millions) <sup>d</sup>	Roadkill as Percent Overwintering Population	
		Hotspot Zone Areas <sup>b</sup>	Entire Funnel <sup>c</sup> (millions)	Texas Portion <sup>c</sup> (millions)				Entire Funnel	Texas Portion
<i>Central Funnel</i>									
2016	2.7127	75,691	2.82	1.57	6.15%	2.91	61.401	4.60%	2.55%
2017	0.7737	0	0.81	0.45	0.00%	2.48	52.328	1.54%	0.85%
2018	5.7256	1,370	5.96	3.31	0.05%	6.05	127.655	4.67%	2.59%
2019	0.7091	299	0.74	0.41	0.09%	2.83	59.713	1.24%	0.69%
2020	2.4061	17,898	2.05	1.09	1.64%	2.10	44.31	4.62%	2.46%
<i>Coastal Funnel</i>									
2018	0.7245	4,478	0.41	0.22	2.80%	6.05	127.655	0.32%	0.17%
2019	0.1304	0	0.07	0.04	0.00%	2.83	59.713	0.12%	0.06%
2020	0.2128	1,651	0.10	0.05	3.30%	2.10	44.31	0.23%	0.11%

<sup>a</sup>Data of 2016-2019 for thinned data from in Part III Chapter 2. Data from 2020 thinned to 10 km with adventitious transects in potential monarch roadkill hotspots removed.

<sup>b</sup>Hotspot data of 2016-2019 from Table 4 of Part III Chapter 2. Hotspot data of 2020 from Table 4.

<sup>c</sup>Represents 10 x Thinned Presence/Absence Roadkill per 100 m x road lengths in Table 1. Roadkill from hotspot zones are excluded from totals, but are mostly implicitly represented by transect data from hotspots that were included in calculating the average thinned presence/absence roadkill per 100 m.

<sup>d</sup>Hectares monarchs x 21.1 million monarchs/ha, following Thogmartin et al. (2017).



**Table 6. Texas fall 2020 roadside monarch preferred nectar plants per 100 m x 10 m for different transect types.<sup>a</sup>**

Monarch-Preferred Nectar Plants	Plant Counts per 100 m x 10 m Transect Type		
	Random Dispersed <sup>b</sup> (53)	Dispersed (156)	Adventitious (16)
Milkweeds ( <i>Asclepias</i> spp.)	1.79 ± 5.2 [0 – 35; 36%]a	4.94 ± 12.54 [0 – 88; 40%]a	4.44 ± 6.47 [0 – 18; 50%]a
Non-Milkweeds	--	44.62 ± 88.98 [0 – 788; 65%]b	133.00 ± 183.34 [0 – 560; 69%]a

<sup>a</sup>Means in the same row with the same letter are not significantly different ( $P < 0.05$ ; Kruskal-Wallis Test followed by Wilcoxon Rank Sum Test with Holms correction). Data combined for Central and Coastal funnels.

<sup>b</sup>Only milkweed plants counted for Random Dispersed transects.

**Table 7. Milkweed plant transect counts in fall 2020 monarch migratory Central and Coastal funnels.**

Species	Plant Counts per Combined Inner and Outer 50m x 10m Transects (Percent of Taxa) (n) <sup>a</sup>		Plants per Combined Inner and Outer 50m x 10m Transects (Mean ± SD) (n) <sup>a</sup>		Plants per 50m x 10m Transect where at Least one Transect Occupied (Mean ± SD) (n) [% Inner vs Outer Transect] <sup>a</sup>		Mean Stems per Plant in all 50m x 10m Transects (Mean ± SD) (n) <sup>b</sup>		Estimated Stems per Species in Occupied 50m x 10m Transects (Percent of Taxa) <sup>b,c</sup>		Mean Length Longest Stems per Plant (cm) (Mean ± SD) (n) <sup>b</sup>	
	Central Funnel (810)	Coastal Funnel (126)	Central Funnel (149)	Coastal Funnel (76)	Inner Transect < 5 m from Road Edge	Outer Transect 5 – 10 m from Road Edge	Inner Transect < 5 m from Road Edge	Outer Transect 5 – 10 m from Road Edge	Central Funnel	Coastal Funnel	Inner Transect < 5 m from Road Edge	Outer Transect 5 – 10 m from Road Edge
	Antelopehorns ( <i>A. asperula</i> ssp. <i>capricornu</i> ) Green antelopehorn ( <i>Asclepias viridis</i> ) Zizotes Milkweed ( <i>A. oenotheroides</i> ) Broadleaf Milkweed ( <i>A. latifolia</i> ) Slim Milkweed ( <i>A. linearis</i> ) Green Comet Milkweed ( <i>A. viridiflora</i> ) Spider Milkweed ( <i>A. asperula</i> ssp. <i>asperula</i> )	354 (44%)	0	2.38 ± 9.3a	0.0 ± 0.0b	4.73 ± 10.43 (37) [49%]a	4.84 ± 10.06 (37) [51%]a	2.97 ± 2.45 (87)a	4.32 ± 4.33 (65)a	1,295 (41%)	0 (0%)	23.77 ± 27.79 (87)a
antelopehorn ( <i>Asclepias viridis</i> ) Zizotes Milkweed ( <i>A. oenotheroides</i> ) Broadleaf Milkweed ( <i>A. latifolia</i> ) Slim Milkweed ( <i>A. linearis</i> ) Green Comet Milkweed ( <i>A. viridiflora</i> ) Spider Milkweed ( <i>A. asperula</i> ssp. <i>asperula</i> )	225 (28%)	50 (40%)	1.51 ± 7.96a	0.66 ± 2.91a	4.86 ± 5.85 (21) [37%]a	8.24 ± 17.24 (21) [63%]a	1.46 ± 0.89 (56)a	8.94 ± 12.43 (50)b	1,389 (44%)	309 (62%)	25.41 ± 10.68 (56)a	20.1 ± 17.03 (50)a
antelopehorn ( <i>Asclepias viridis</i> ) Zizotes Milkweed ( <i>A. oenotheroides</i> ) Broadleaf Milkweed ( <i>A. latifolia</i> ) Slim Milkweed ( <i>A. linearis</i> ) Green Comet Milkweed ( <i>A. viridiflora</i> ) Spider Milkweed ( <i>A. asperula</i> ssp. <i>asperula</i> )	118 (15%)	76 (60%)	0.79 ± 2.18a	1 ± 5.36a	3.08 ± 4.29 (40) [64%]a	1.73 ± 4.05 (40) [36%]a	2.31 ± 1.82 (87)a	2.8 ± 2.49 (35)a	293 (9%)	189 (38%)	14.37 ± 6.65 (87)a	19.34 ± 6.82 (35)b
antelopehorn ( <i>Asclepias viridis</i> ) Zizotes Milkweed ( <i>A. oenotheroides</i> ) Broadleaf Milkweed ( <i>A. latifolia</i> ) Slim Milkweed ( <i>A. linearis</i> ) Green Comet Milkweed ( <i>A. viridiflora</i> ) Spider Milkweed ( <i>A. asperula</i> ssp. <i>asperula</i> )	81 (10%)	0	0.54 ± 2.43a	0.0 ± 0.0a	2.3 ± 3.74 (10) [28%]a	5.8 ± 5.18 (10) [72%]a	1.63 ± 1.13 (24)	1.67 ± 1.14 (49)	134 (4%)	0 (0%)	23.04 ± 10.55 (24)a	28.67 ± 14.85 (49)a
antelopehorn ( <i>Asclepias viridis</i> ) Zizotes Milkweed ( <i>A. oenotheroides</i> ) Broadleaf Milkweed ( <i>A. latifolia</i> ) Slim Milkweed ( <i>A. linearis</i> ) Green Comet Milkweed ( <i>A. viridiflora</i> ) Spider Milkweed ( <i>A. asperula</i> ssp. <i>asperula</i> )	17 (2%)	0	0.11 ± 1.39	0.0 ± 0.0	5 ± 0 (1) [29%]	12 ± 0 (1) [71%]	1.75 ± 0.5 (4)	1.33 ± 0.58 (3)	25 (1%)	0 (0%)	27.5 ± 9.98 (4)	22 ± 1.73 (3)
antelopehorn ( <i>Asclepias viridis</i> ) Zizotes Milkweed ( <i>A. oenotheroides</i> ) Broadleaf Milkweed ( <i>A. latifolia</i> ) Slim Milkweed ( <i>A. linearis</i> ) Green Comet Milkweed ( <i>A. viridiflora</i> ) Spider Milkweed ( <i>A. asperula</i> ssp. <i>asperula</i> )	12 (1%)	0	0.08 ± 0.39	0.0 ± 0.0	1 ± 0.82 (7) [58%]	0.71 ± 1.25 (7) [42%]	1 ± 0.63 (6)	1 ± 0 (5)	12 (<1%)	0 (0%)	17.5 ± 15.08 (6)	23.8 ± 1.64 (5)
antelopehorn ( <i>Asclepias viridis</i> ) Zizotes Milkweed ( <i>A. oenotheroides</i> ) Broadleaf Milkweed ( <i>A. latifolia</i> ) Slim Milkweed ( <i>A. linearis</i> ) Green Comet Milkweed ( <i>A. viridiflora</i> ) Spider Milkweed ( <i>A. asperula</i> ssp. <i>asperula</i> )	3 (<1%)	0	0.02 ± 0.18	0.0 ± 0.0	1 ± 1.41 (2) [67%]	0.5 ± 0.71 (2) [33%]	2.5 ± 2.12 (2)	--	8 (<1%)	0 (0%)	25 ± 2.83 (2)	--
<b>Total</b>	<b>810 (100%)</b>	<b>126 (100%)</b>	<b>4.47 ± 11.74a</b>	<b>1.66 ± 5.99b</b>					<b>3,156 (100%)</b>	<b>498 (100%)</b>		

<sup>a</sup>From data of all transects, including both dispersed, adventitious, and random dispersed transects.

<sup>b</sup>From data of dispersed and adventitious transects only.

<sup>c</sup>Plant Counts x Mean Stems Per Plant in Inner and Outer Transects Weighted by % Plants in Inner and Outer Transects

**Table 8. Monarch-preferred nectar plant 50 m x 5 m dispersed transect percent cover for various taxa in fall 2020 monarch migratory Central and Coastal funnels<sup>a</sup>**

Species	Percent Cover per 50m x 5m Transect, Mean ± SD (% of Species)			Texas Estimated Total Area (Ha.) within 5 m Roadway <sup>b</sup>
	Dispersed Transects (107)	Adventitious Transects (8)	All Transects (115)	
<i>Central Funnel</i>				
Engelmann Daisy ( <i>Engelmannia peristenia</i> )	0.21 ± 0.69 (27%)	0.38 ± 0.74 (43%)	0.23 ± 0.69 (29%)	1,023
Spanish Gold ( <i>Grindelia ciliata</i> )	0.15 ± 0.67 (19%)	0 ± 0 (0%)	0.14 ± 0.65 (18%)	629
Green Antelopehorns ( <i>Asclepias viridis</i> )	0.05 ± 0.25 (6%)	0.13 ± 0.35 (14%)	0.05 ± 0.26 (7%)	236
Dotted Blazing Star ( <i>Liatriis punctata</i> )	0.06 ± 0.49 (7%)	0.00 ± 0.00 (0%)	0.05 ± 0.47 (7%)	236
Heath Aster ( <i>Symphyotrichum ericoides</i> )	0.06 ± 0.27 (7%)	0.00 ± 0.00 (0%)	0.05 ± 0.26 (7%)	236
Antelopehorns ( <i>Asclepias asperula</i> )	0.05 ± 0.25 (6%)	0.00 ± 0.00 (0%)	0.04 ± 0.24 (5%)	197
Zexmenia ( <i>Wedelia acapulcensis</i> var. <i>hispidia</i> )	0.05 ± 0.32 (6%)	0.00 ± 0.00 (0%)	0.04 ± 0.31 (5%)	197
Zizotes Milkweed ( <i>Asclepias oenotheroides</i> )	0.04 ± 0.19 (5%)	0.00 ± 0.00 (0%)	0.03 ± 0.18 (4%)	157
Annual Sunflower ( <i>Helianthus annuus</i> )	0.04 ± 0.3 (5%)	0.00 ± 0.00 (0%)	0.03 ± 0.29 (4%)	157
Bitter Sneezeweed ( <i>Helenium amarum</i> )	0.03 ± 0.29 (4%)	0.00 ± 0.00 (0%)	0.03 ± 0.28 (3%)	118
Maximilian Sunflower ( <i>Helianthus maximiliani</i> )	0.03 ± 0.29 (4%)	0.00 ± 0.00 (0%)	0.03 ± 0.28 (3%)	118
Texas Vervain ( <i>Verbena halei</i> )	0.02 ± 0.14 (2%)	0.00 ± 0.00 (0%)	0.02 ± 0.13 (2%)	79
Broadleaf Milkweed ( <i>Asclepias latifolia</i> )	0 ± 0 (0%)	0.13 ± 0.35 (14%)	0.01 ± 0.09 (1%)	39
Slim Milkweed ( <i>Asclepias linearis</i> )	0.01 ± 0.1 (1%)	0.00 ± 0.00 (0%)	0.01 ± 0.09 (1%)	39
Lyreleaf Greeneyes ( <i>Berlandiera lyrata</i> )	0.01 ± 0.1 (1%)	0.00 ± 0.00 (0%)	0.01 ± 0.09 (1%)	39
Prairie Sunflower ( <i>Helianthus petiolaris</i> )	0 ± 0 (0%)	0.13 ± 0.35 (14%)	0.01 ± 0.09 (1%)	39
Golden Crownbeard ( <i>Verbesina encelioides</i> )	0 ± 0 (0%)	0.13 ± 0.35 (14%)	0.01 ± 0.09 (1%)	39
<i>Total</i>				3,579
<i>Coastal Funnel</i>				
Camphor Daisy ( <i>Heterotheca subaxillaris</i> )	0.1 ± 0.72 (17%)	3.67 ± 9.92 (72%)	0.67 ± 4.03 (51%)	1,459
Climbing Milkweed Vine ( <i>Funastrum cynanchoides</i> )	0.29 ± 1.47 (48%)	0.00 ± 0.00 (0%)	0.25 ± 1.35 (19%)	537

**Table 8 (cont.). Monarch-preferred nectar plant 50 m x 5 m dispersed transect percent cover for various taxa in fall 2020 monarch migratory Central and Coastal funnels<sup>a</sup>**

Species	Percent Cover per 50m x 5m Transect, Mean ± SD (% of Species)			Texas Estimated Total Area (Ha.) within 5 m Roadway <sup>b</sup>
	Dispersed Transects	Adventitious Transects	All Transects	
	(107)	(8)	(115)	
<i>Coastal Funnel (cont.)</i>				
Seaside Goldenrod ( <i>Solidago sempervirens</i> )	0.08 ± 0.35 (14%)	0.89 ± 1.69 (17%)	0.21 ± 0.77 (16%)	461
Texas Vervain ( <i>Verbena halei</i> )	0.08 ± 0.35 (14%)	0.56 ± 1.67 (11%)	0.16 ± 0.73 (12%)	345
Coreopsis ( <i>Coreopsis</i> sp.)	0.02 ± 0.14 (3%)	0.00 ± 0.00 (0%)	0.02 ± 0.13 (1%)	38
Lantana ( <i>Lantana</i> sp.)	0.02 ± 0.14 (3%)	0.00 ± 0.00 (0%)	0.02 ± 0.13 (1%)	38
<i>Total</i>				<i>2,879</i>

<sup>a</sup>Plots are biased towards milkweed and some other monarch nectar plants, for which searches were made over 50 km units.

<sup>b</sup>Mean percent cover for all transects multiplied by area (ha) to 5 m on either side of highway using highway lengths from Table 1 (452, 270 ha for Central Funnel; 218,790 ha for Coastal Funnel). Plots were biased towards presence of milkweed and some other common nectar plants.



**Table 9. Monarch larvae (5<sup>th</sup> instars) per milkweed plant for roadside transects.<sup>a</sup>**

Statistic	Monarch Larvae (5 <sup>th</sup> instars) per 100 m x 10 m Transect				
	Mean ± SD (Range) [Total Larvae]				
	Green Antelopehorn	Antelopehorns	Zizotes Milkweed	Broadleaf Milkweed	All Milkweeds
Central Funnel (n = 115)	0.00 ± 0.00a (0-0) [0]	0.00 ± 0.00a (0-0) [0]	0.00 ± 0.00a (0-0) [0]	0.01 ± 0.09a (0-1) [1]	0.00 ± 0.00a (0-0) [0]
Coastal Funnel (n = 58)	0.00 ± 0.00a (0-0) [0]	0.00 ± 0.00a (0-0) [0]	0.07 ± 0.53a (0-4) [4]	0.00 ± 0.00a (0-0) [0]	0.00 ± 0.00a (0-0) [0]

<sup>a</sup>Includes all disperse and adventitious transects where up to six milkweed plants per species were examined for larvae in both inner and outer 100m x 5m roadside transects. Means in the same row with the same letter are not significantly different (P < 0.05; Kruskal-Wallis Test).

Figures

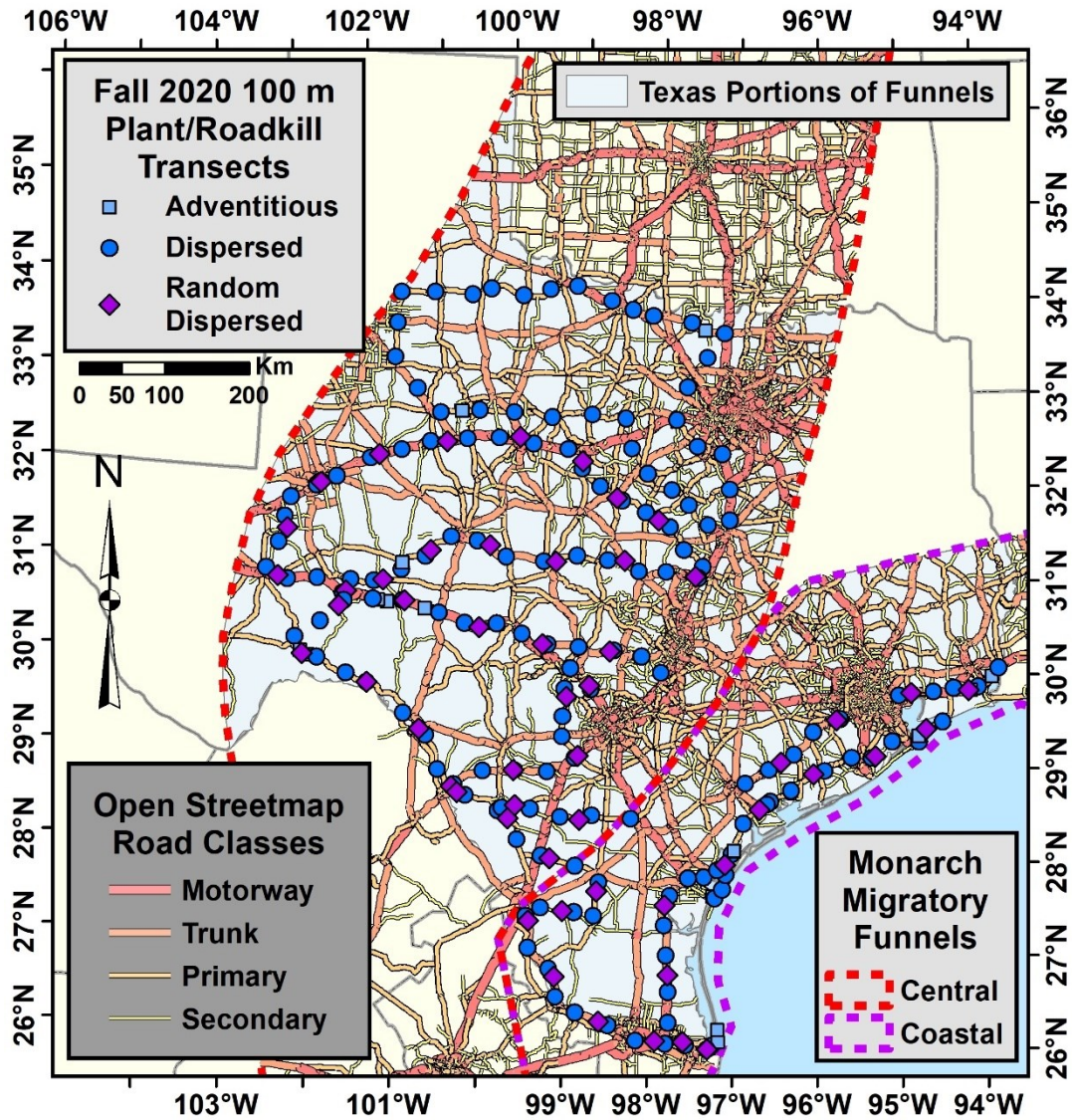
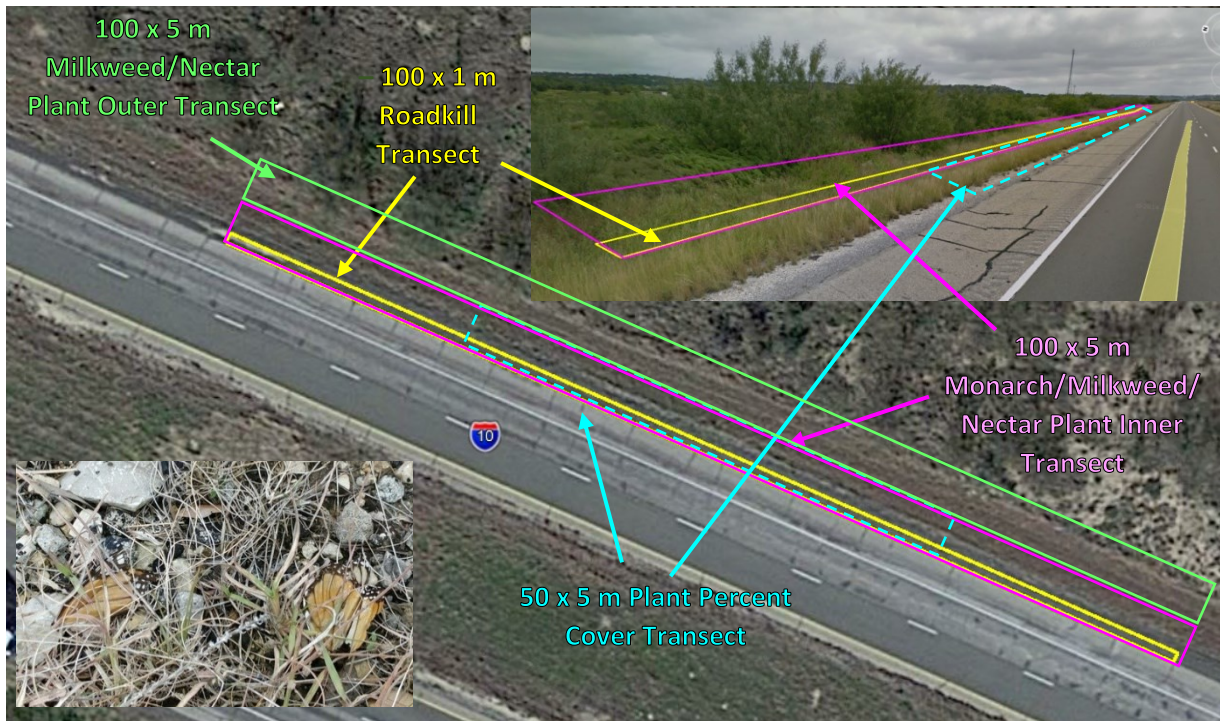


Figure 1. Distribution of fall 2020 roadkill and roadside vegetation transects over Texas roadways within the monarch migratory Central and Coastal funnels (Random Dispersed transects only for milkweeds).



**Figure 2. Layout of 100m x 1 m roadkill transect (yellow), Inner 100 x 5 m monarch/milkweed transect (pink), Outer 100m x 5 m milkweed/nectar plant transect (green), and 50 x 5 m plant percent cover transect (blue dashed).**





**Figure 3. (A-B) One of four fifth instar monarch larvae found on *Asclepias oenotheroides* in transect ESCT 08 at SH-361 Redfish Bay Causeway, 4.4 km south of Aransas Pass, Texas (10/27/2020); and (B-C) roadkill monarchs from transect NCNT 25 at US-180, 3.8 km west Roby, Texas, where 10 roadkill monarchs found**

(10/15/2020)



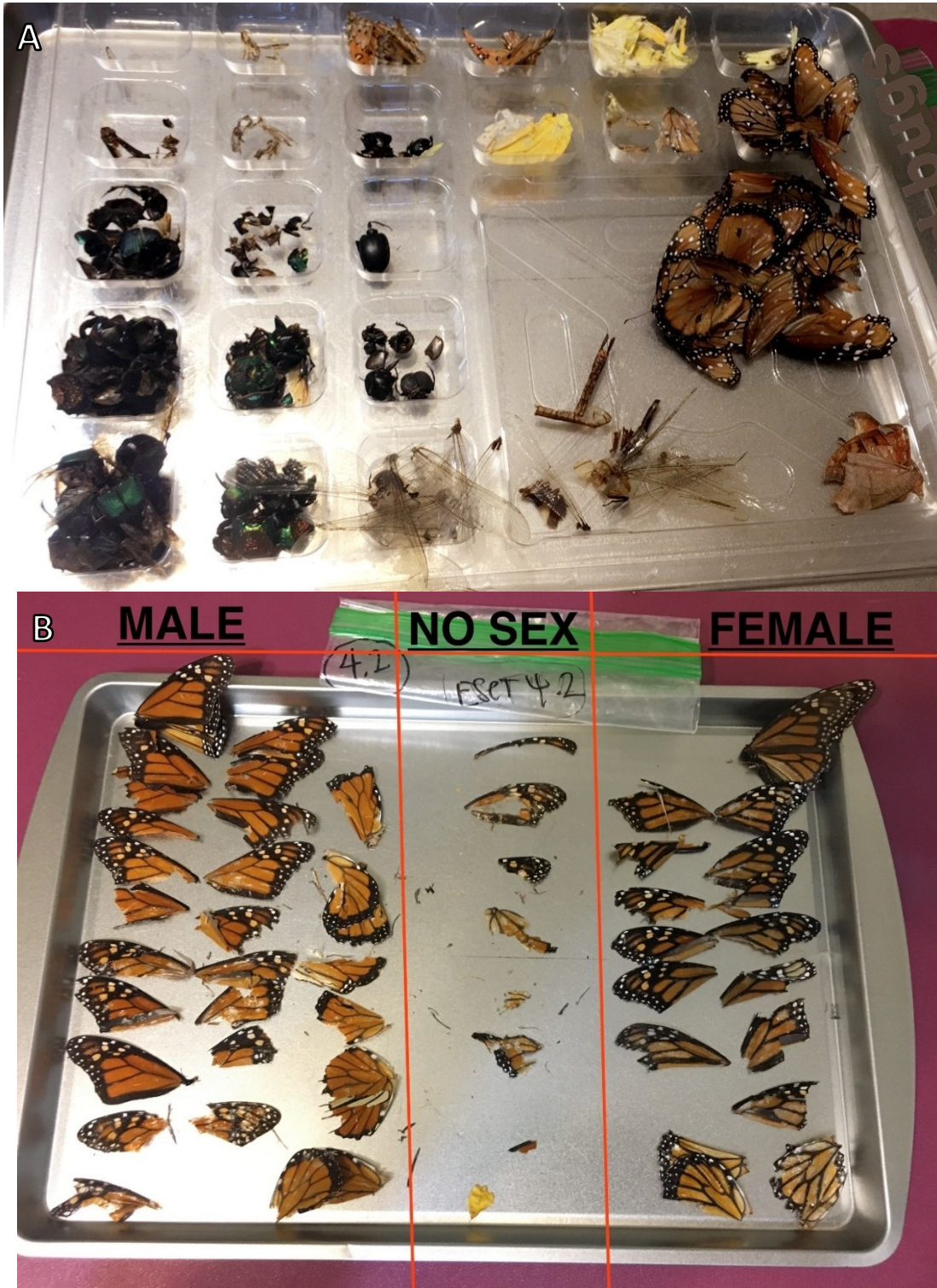
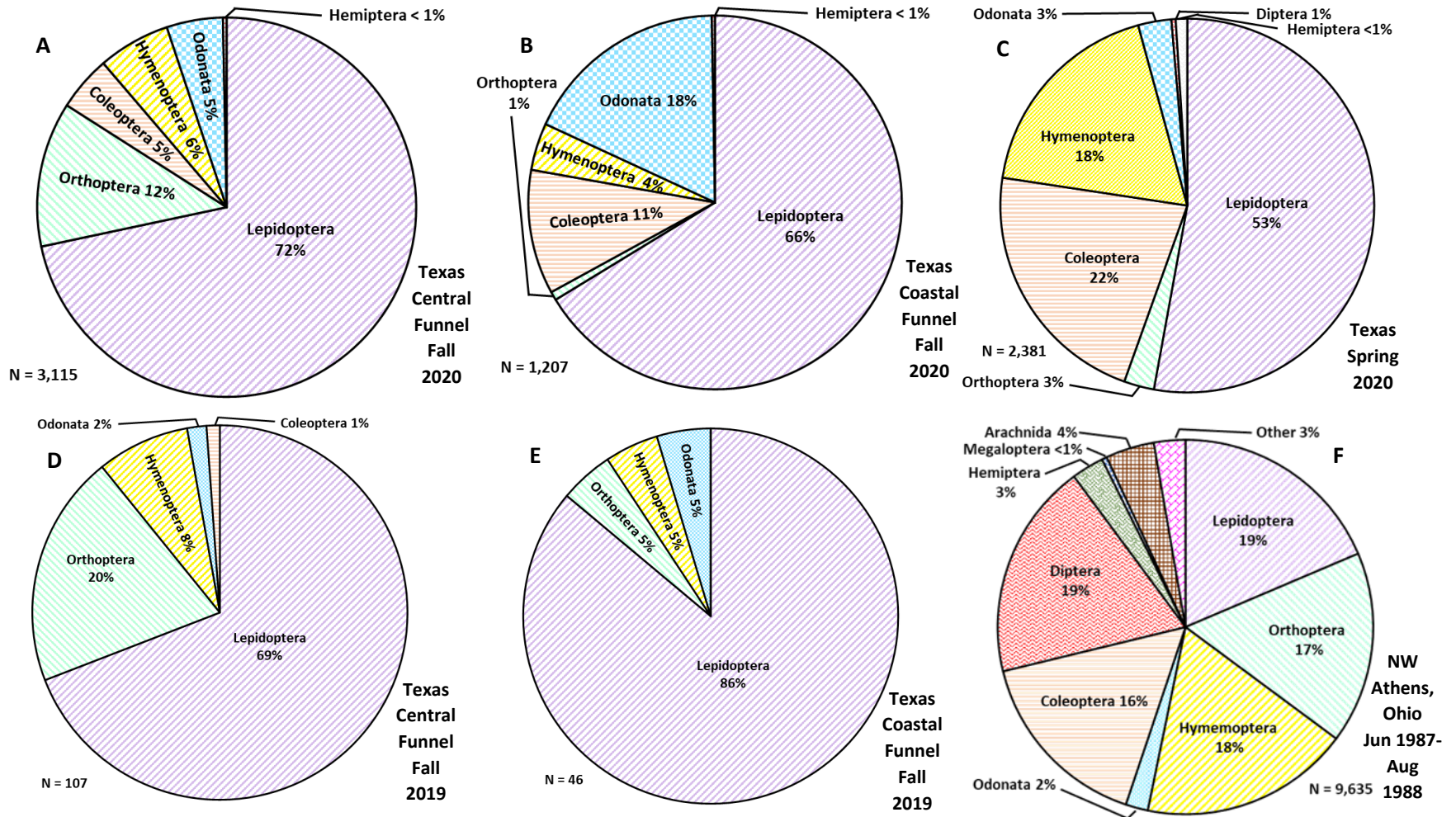
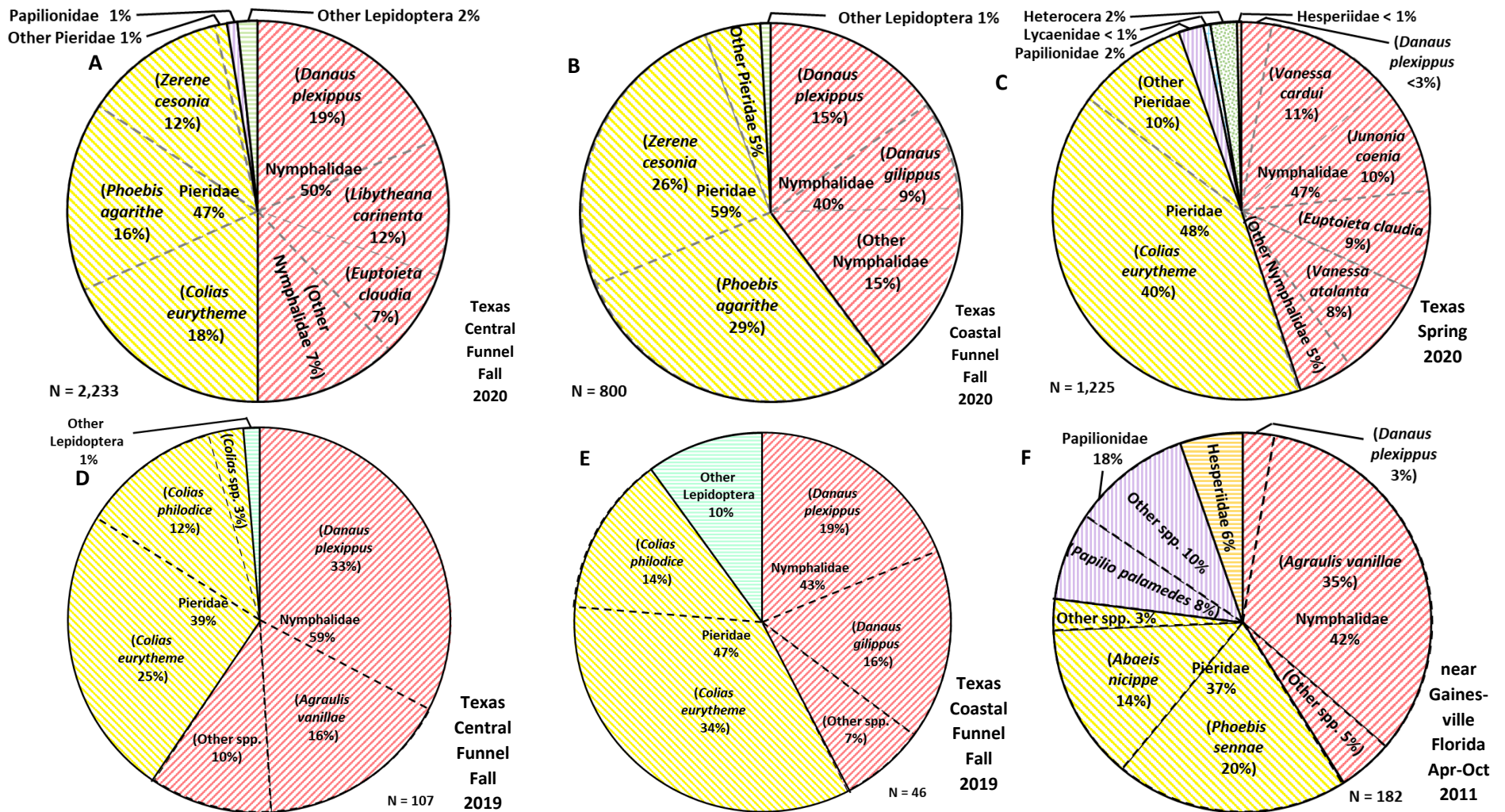


Figure 4. (A) Sorted roadkill insects, including 30 queen butterflies (middle right) and 48 beetles (left), from transect WSCT 04 at US-77, 23 km south Sarita, Texas (12/7/2020); (B) sorted roadkill monarch by sex from transect ESCT 04.2 at SH-35 Lavaca Bay Causeway peninsula 1.5 km west Point Comfort, Texas (11/22/2020).



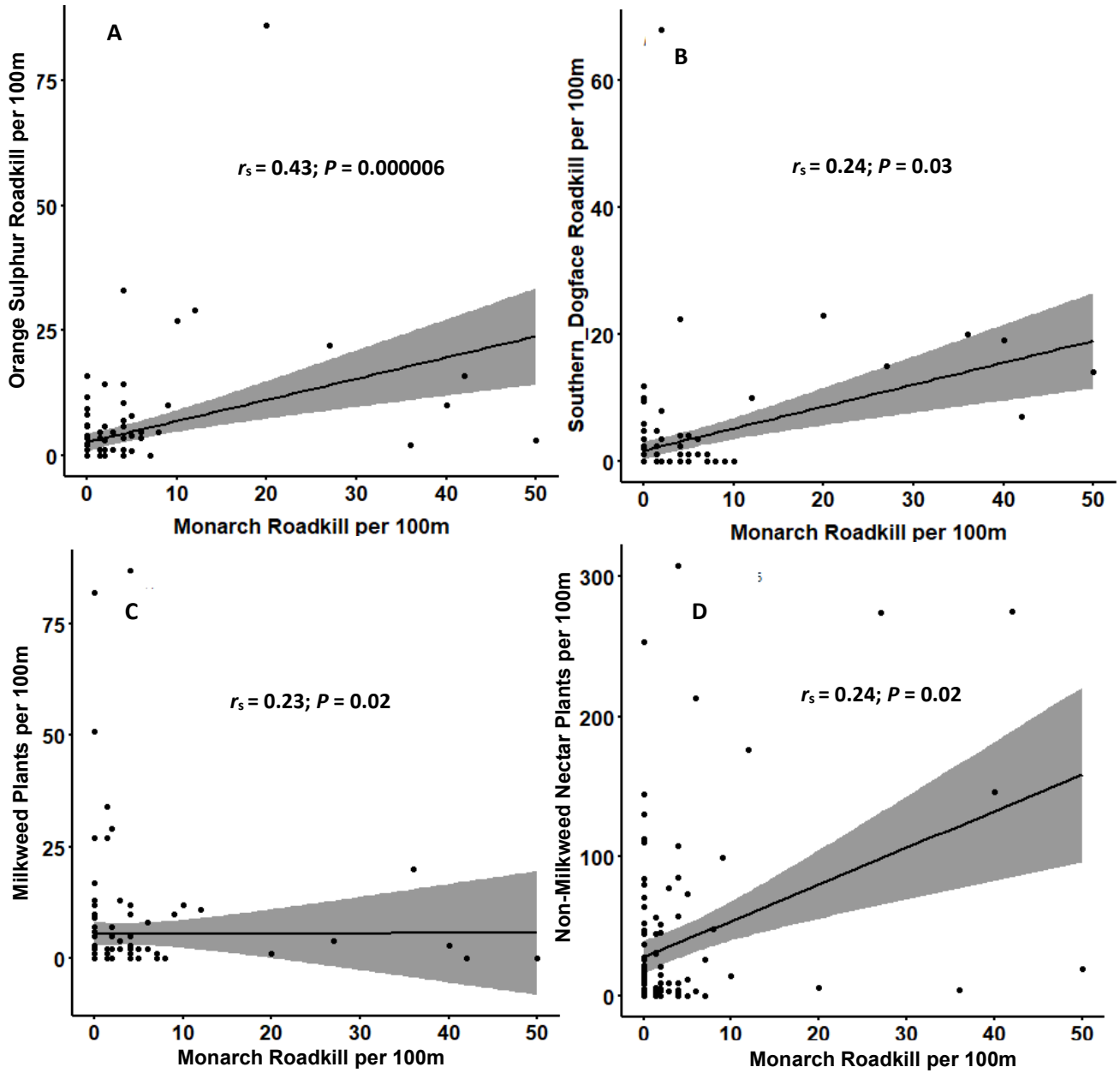


**Figure 5. Percentage roadkill among roadside transects for arthropod taxa in Texas (A-E) and Ohio (F): (A-B) Texas Central (A) and Coastal (B) funnels, Oct-Dec 2020 (Table 2); (C) Texas Central Funnel and eastwards, Apr-May 2020 (Tracy et al. 2020c); (D-E) Texas Central (D) and Coastal (E) funnels, Oct-Nov 2019 (Tracy et al. 2020a); (F) US highway 33, forest, Hocking River, Northwest Athens, Ohio, Jun 1987–Aug 1988 (Seibert and Conover 1991).**



**Figure 6. Percentage roadkill among roadside transects for Lepidoptera taxa in Texas (A-E) and Florida (F): (A-B) Texas Central (A) and Coastal (B) funnels, Oct-Dec 2020 (Table 2); (C) Texas Central Funnel and eastwards, Apr-May 2020 (Tracy et al. 2020c); (D-E) Texas Central (D) and Coastal (E) funnels, Oct-Nov 2019 (Tracy et al. 2020a); (F) Divided highways near Gainesville, Florida, Apr-Oct 2011 (Halbritter et al. 2015).**



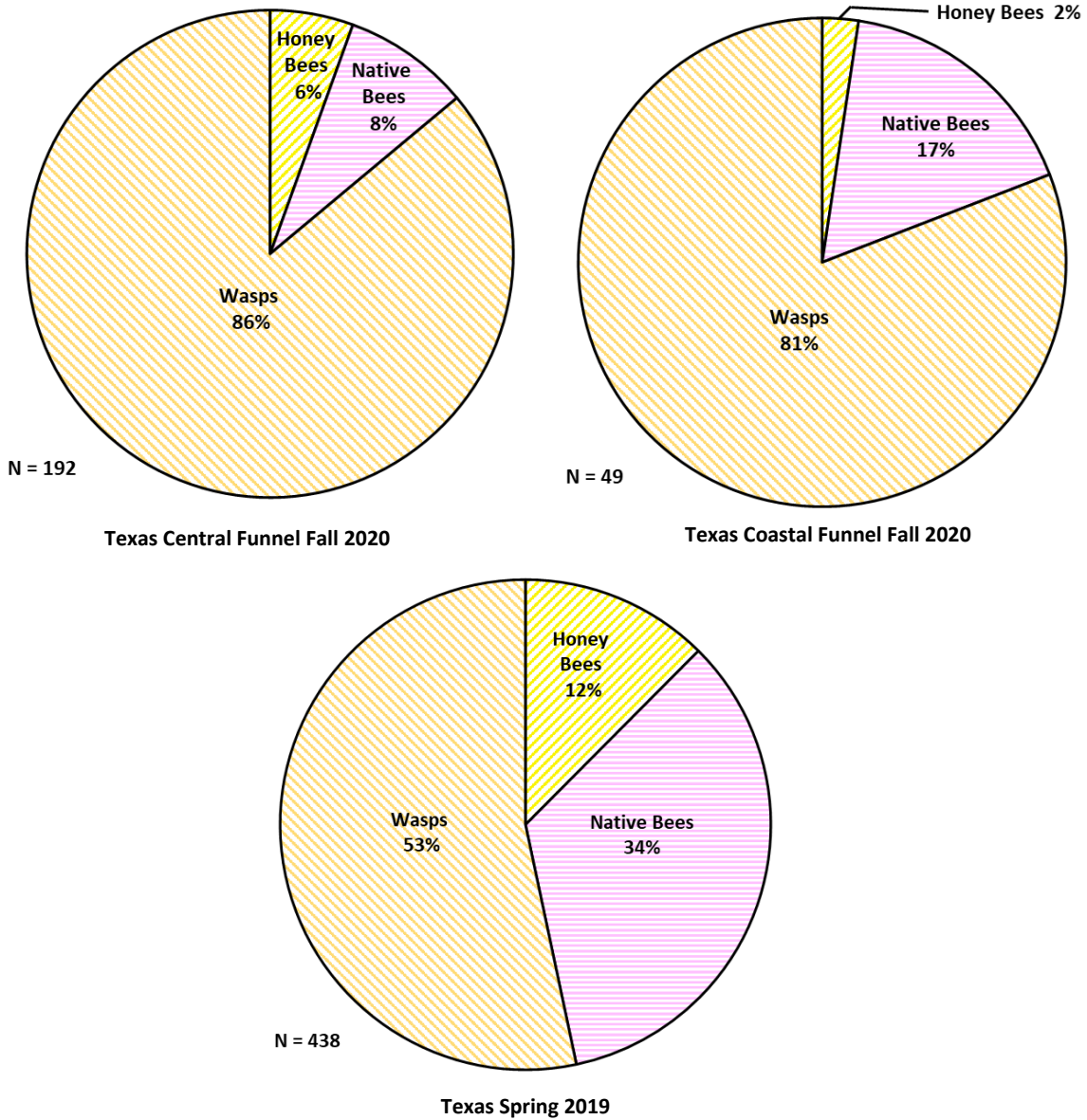


**Figure 7. Spearman’s rank order correlation ( $r_s$ ) between Central Funnel monarch roadkill and (A) orange sulphur roadkill; (B) southern dogface roadkill; (C) milkweed plants; and (D) non-milkweed monarch nectar plants (Holm’s adjusted  $P$ -values; see Table 3; see Fig. A2 for additional correlations).**

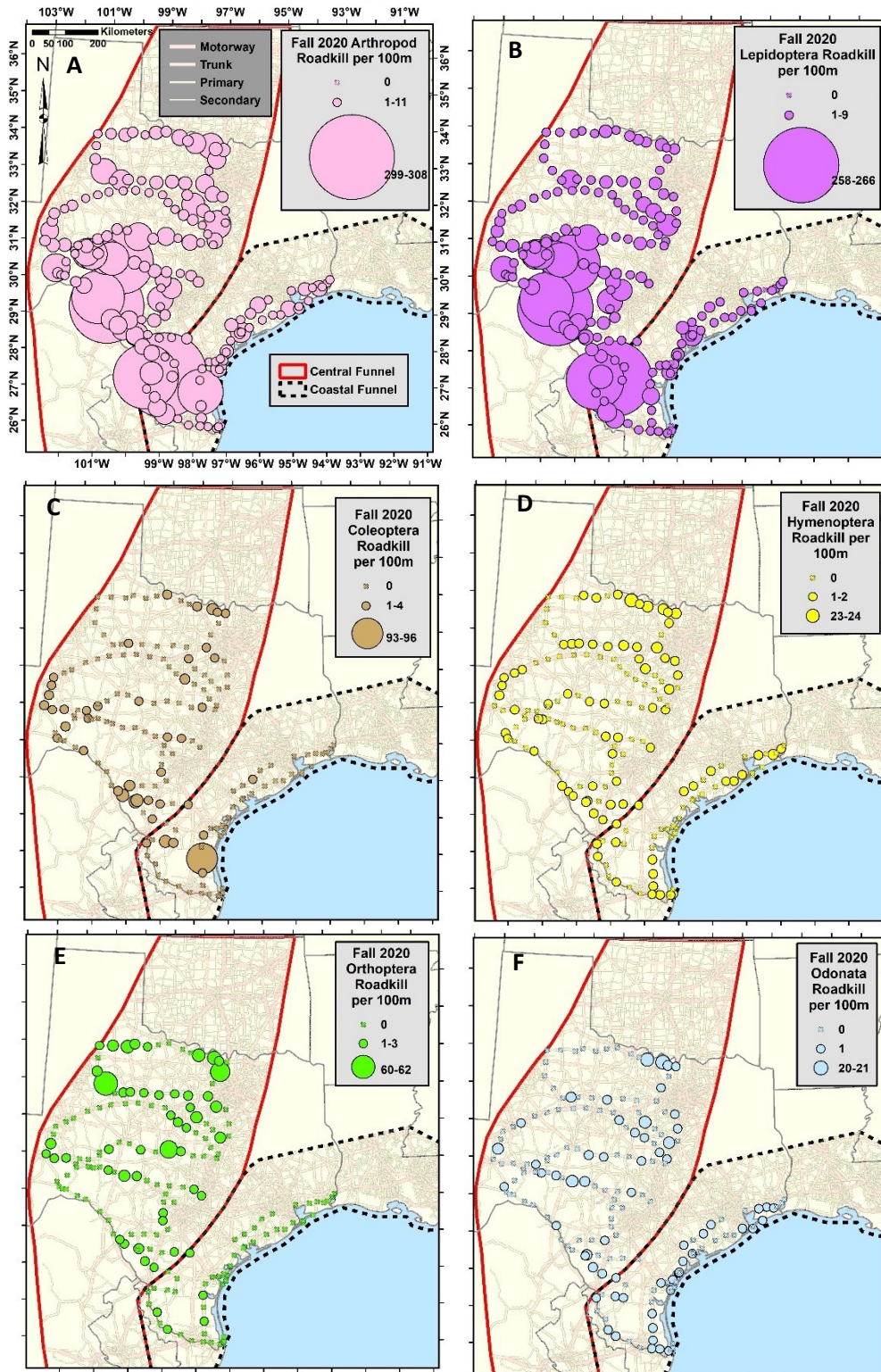




**Figure 8. Common butterfly species in fall 2020 Texas roadkill not reported from fall 2019 roadkill: (A) American snout, *Libytheana carinenta*; (B) large orange sulphur, *Phoebis agarithe* (images, iNaturalist 2021).**

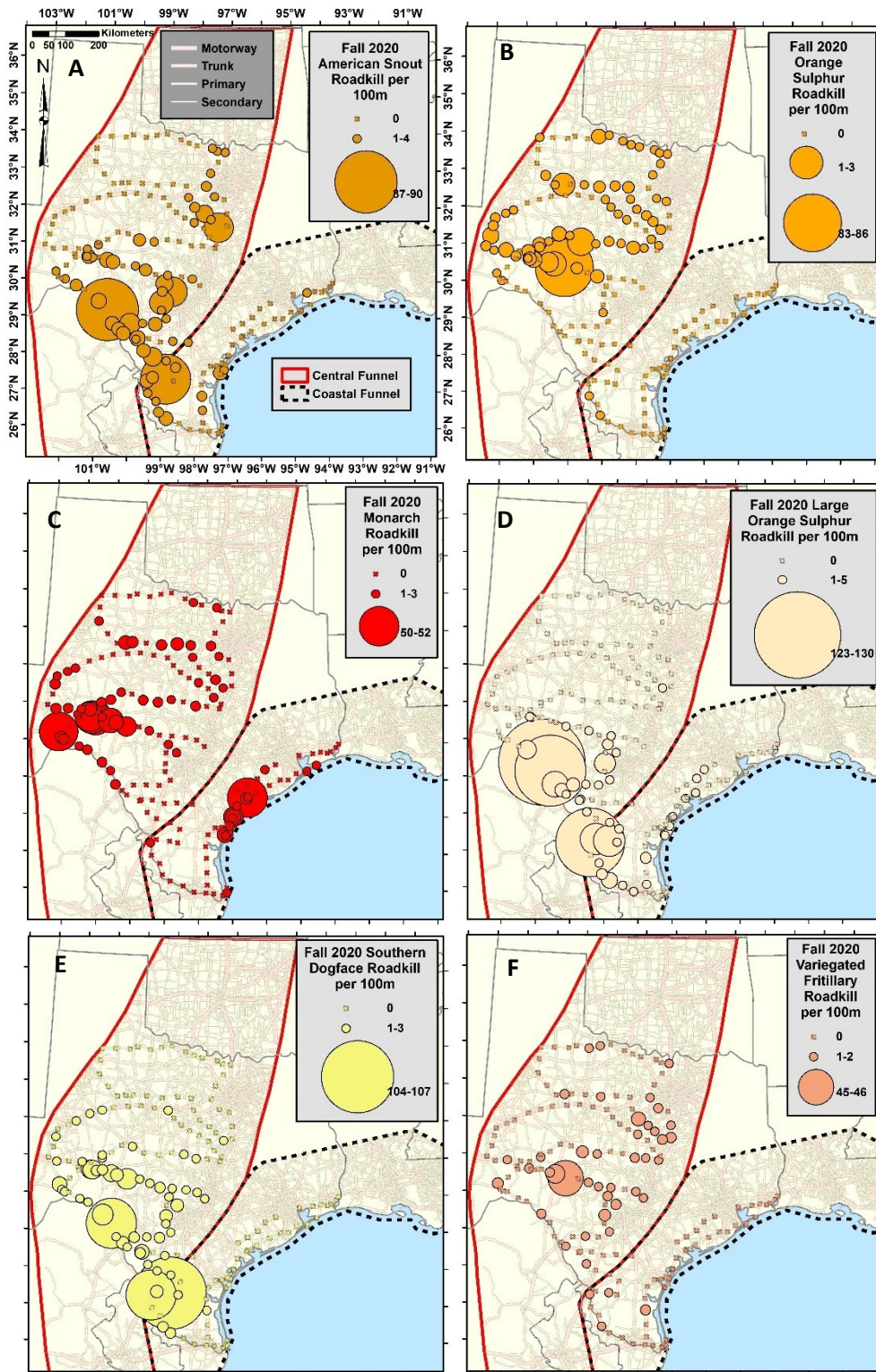


**Figure 9. Percentage roadkill among roadside transects for Hymenoptera taxa from Oct-Dec 2020 in Texas (A) Central and (B) Coastal funnels (Table 2), and from Apr-May 2020 in Texas (Tracy et al. 2020c).**



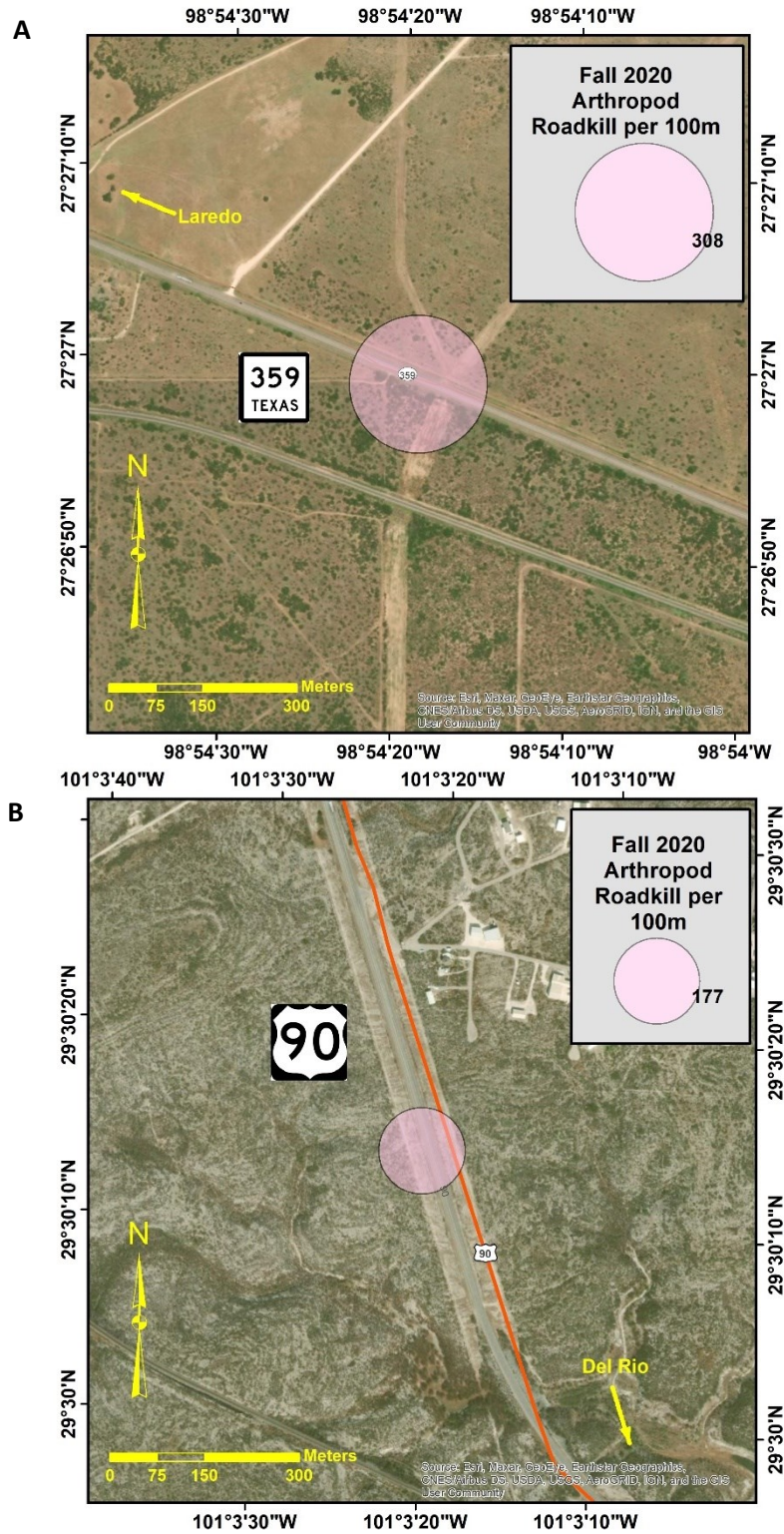
**Figure 10. Distribution of fall 2020 roadkill per 100m x 1m transect (unthinned) for various arthropod taxa in Texas monarch migratory Central Funnel and eastwards: (A) Arthropods; (B) Lepidoptera; (C) Coleoptera; (D) Hymenoptera; (E) Orthoptera; and (F) Odonata (symbols ca. proportional among taxa).**



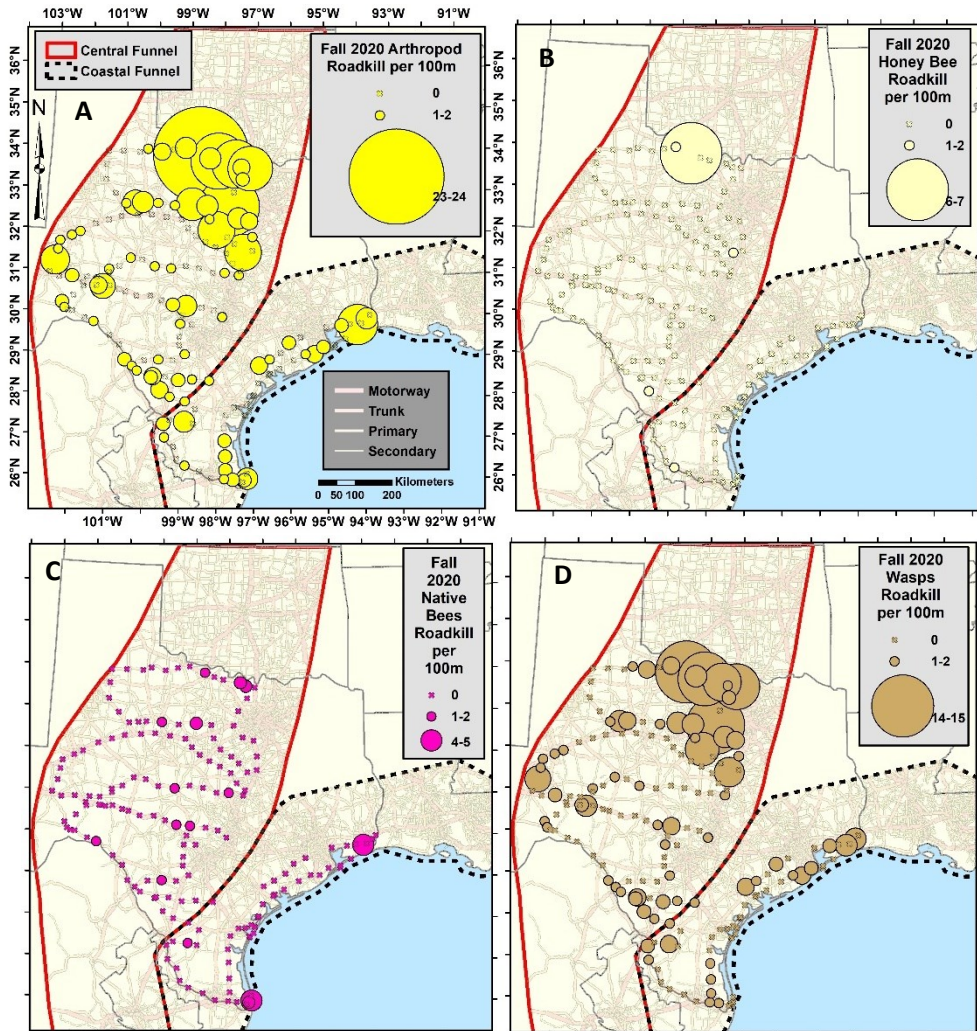


**Figure 11. Distribution of fall 2020 roadkill per 100m x 1m transect (unthinned) for Lepidoptera taxa in Texas monarch migratory Central and Coastal funnels: (A) American Snout; (B) Orange Sulphur; (C) Monarch; (D) Large Orange Sulphur; (E) Southern Dogface; and (F) Variegated Fritillary (symbols ca. proportional among taxa; see Fig. A1 for additional maps).**



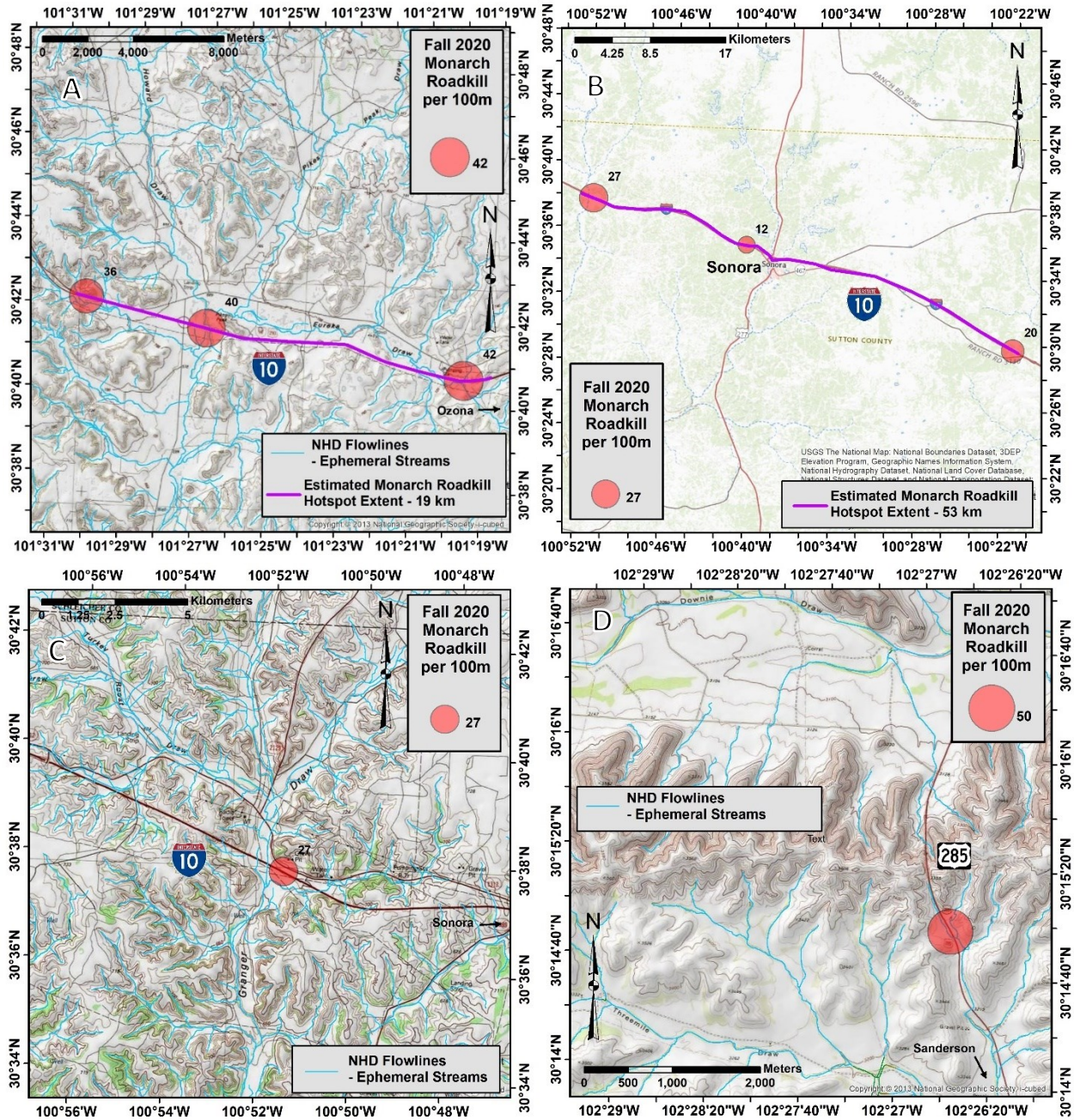


**Figure 12. Fall 2020 arthropod roadkill hotspot zones (A) 55 km east of Laredo along State Highway 359 on 10 December, 2020 (WSCT 21); and (B) 21 km north of Del Rio along US Highway 90 on 11 November, 2020 (SCNT 23) (both mostly southern dogface, large orange sulphur, and American snout).**

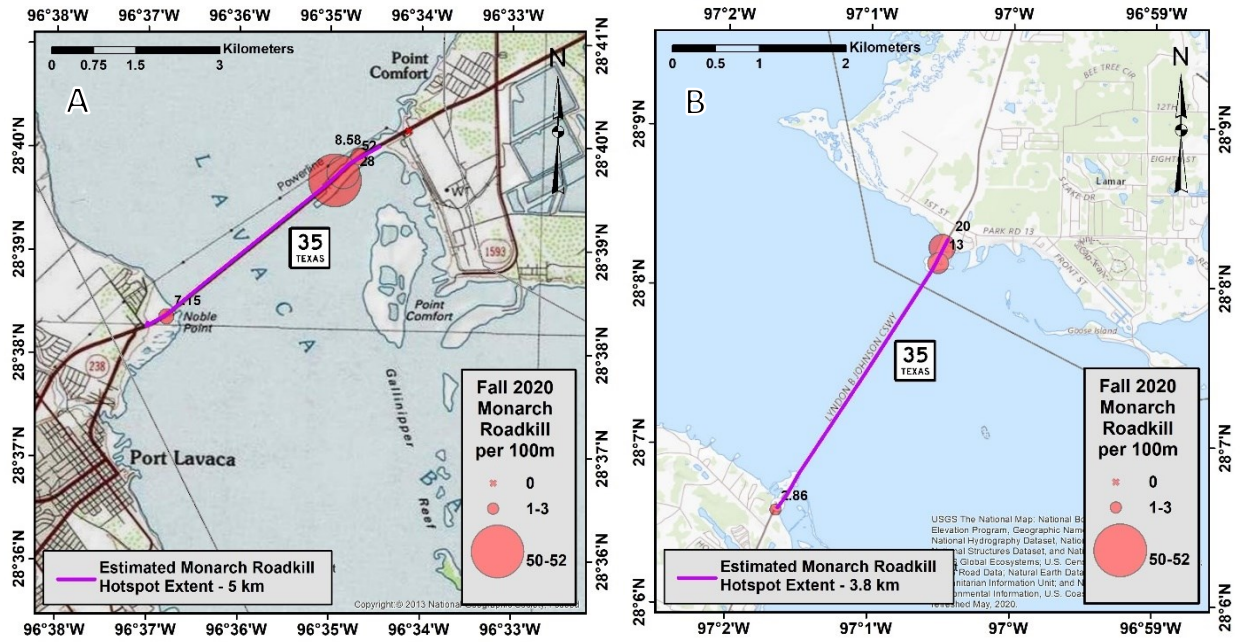


**Figure 13. Distribution of fall 2020 roadkill per 100m x 1m transect (unthinned) for Hymenoptera taxa in Texas monarch migratory Central and Coastal funnels: (A) Hymenoptera; (B) European Honey Bees; (C) Native Bees; and (D) Wasps (symbols ca. proportional among taxa).**



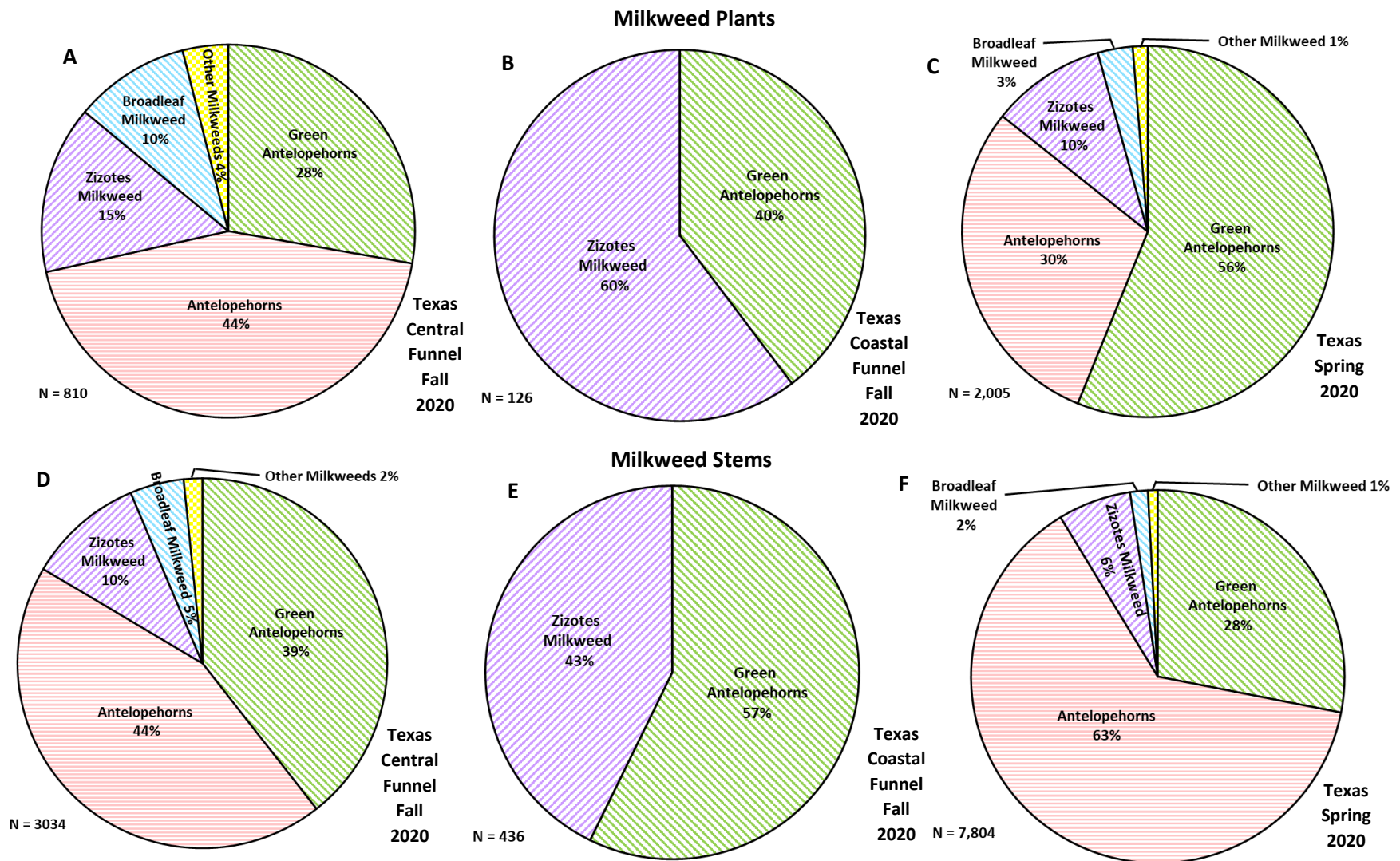


**Figure 14. Fall 2020 Central Funnel monarch roadkill hotspot zones and hotspots with National Hydrography Dataset Plus High Resolution (NHDPlus HR) stream flowlines (USGS 2017) at: (A) Howard/Eureka Draw Hotspot Zone, 11 km west of Ozona on IH-10 (SCNT 12-14; 11/11/2020); (B) Sonora Hotspot Zone, 20 km east to 24 km west Sonora on IH-10 along (SCNT 08-10; 11/10/2020) (see Table 5); (C) Granger Draw Hotspot, 4 km west of Sonora on IH-10 (left hotspot in B, SCNT 10), and (D) Thremile Draw Hotspot, 11 km north of Sanderson on US-285 (SCNT 17; 11/11/2020).**

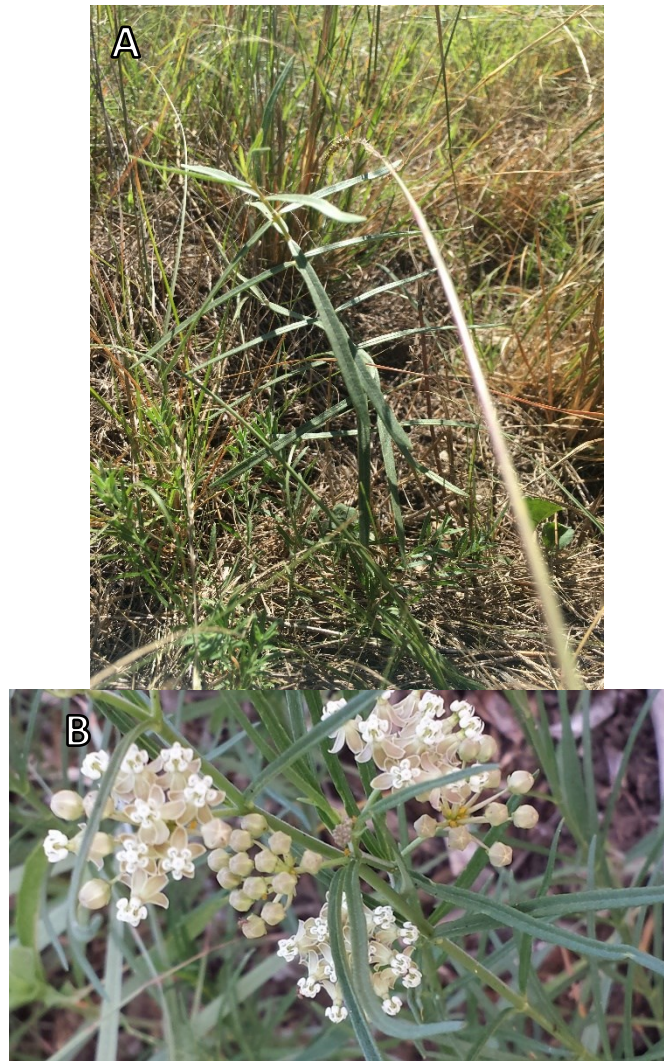


**Figure 15. Fall 2020 Coastal Funnel monarch roadkill hotspot zones (A) Lavaca Bay Causeway Hotspot Zone on SH-35 (ESCT 02.2-04.2, 16; 11/22/2020); and (B) Lyndon B Johnson Causeway Hotspot Zone on SH-35 (ESCT 11,12/13,14; 11/22/2020) (see Table 5).**



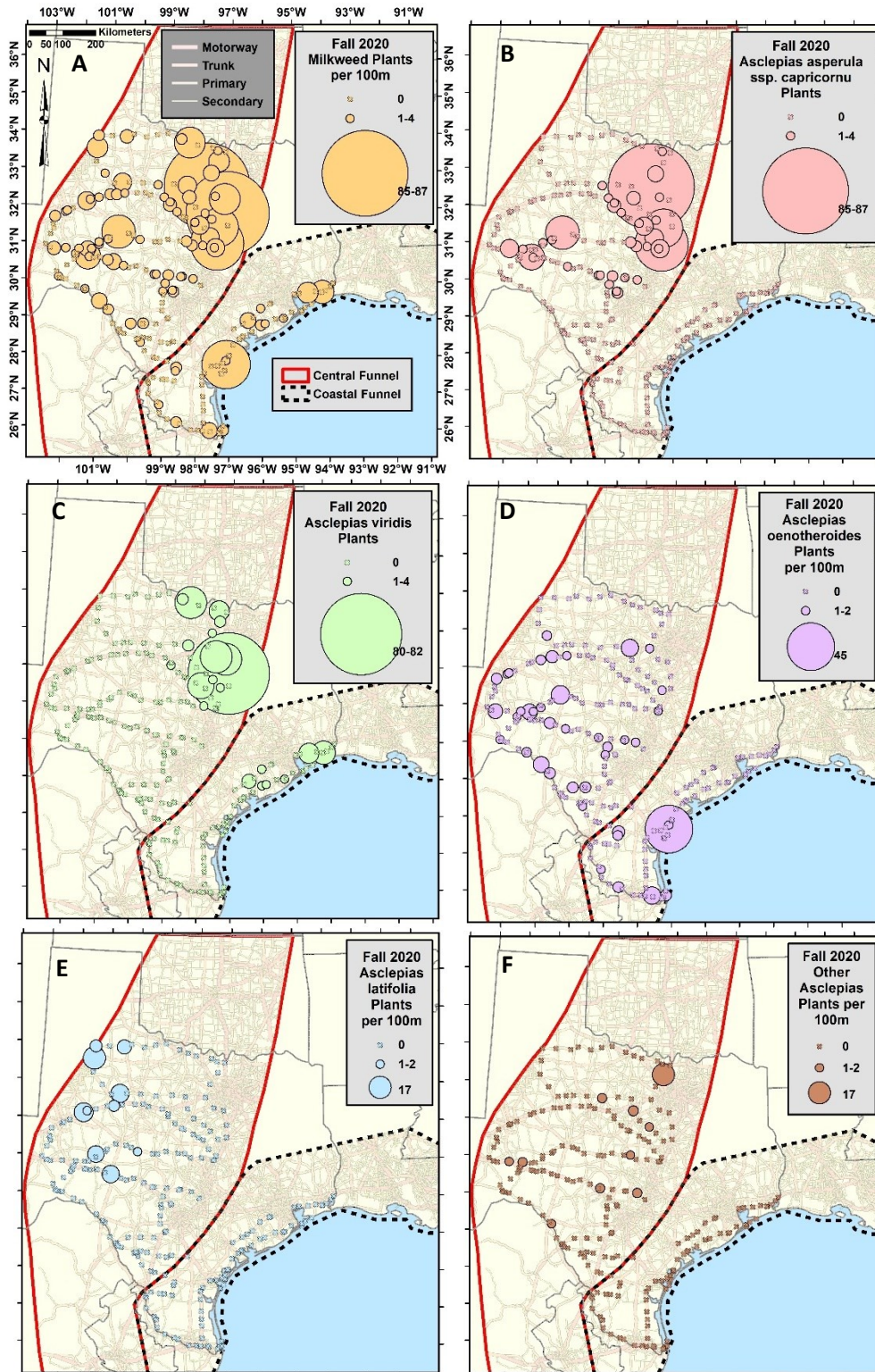


**Figure 16. Percentage (A-C) milkweed plants and (D-F) estimated milkweed stems along roadside transects for Texas Central Funnel (A,D), Texas Coastal Funnel (B,E) for Oct-Dec 2020 (Table 7), and (C,F) Central Funnel and Eastwards in Texas, Apr-May 2020 (Tracy et al. 2020c).**



**Figure 17. (A) Probable slim milkweed, *Asclepias linearis*, on FM 51 northeast of Decatur, Texas (NCNT 07; 10/13/2020) with identified slim milkweed from Lewisville, Texas (iNaturalist 2021).**





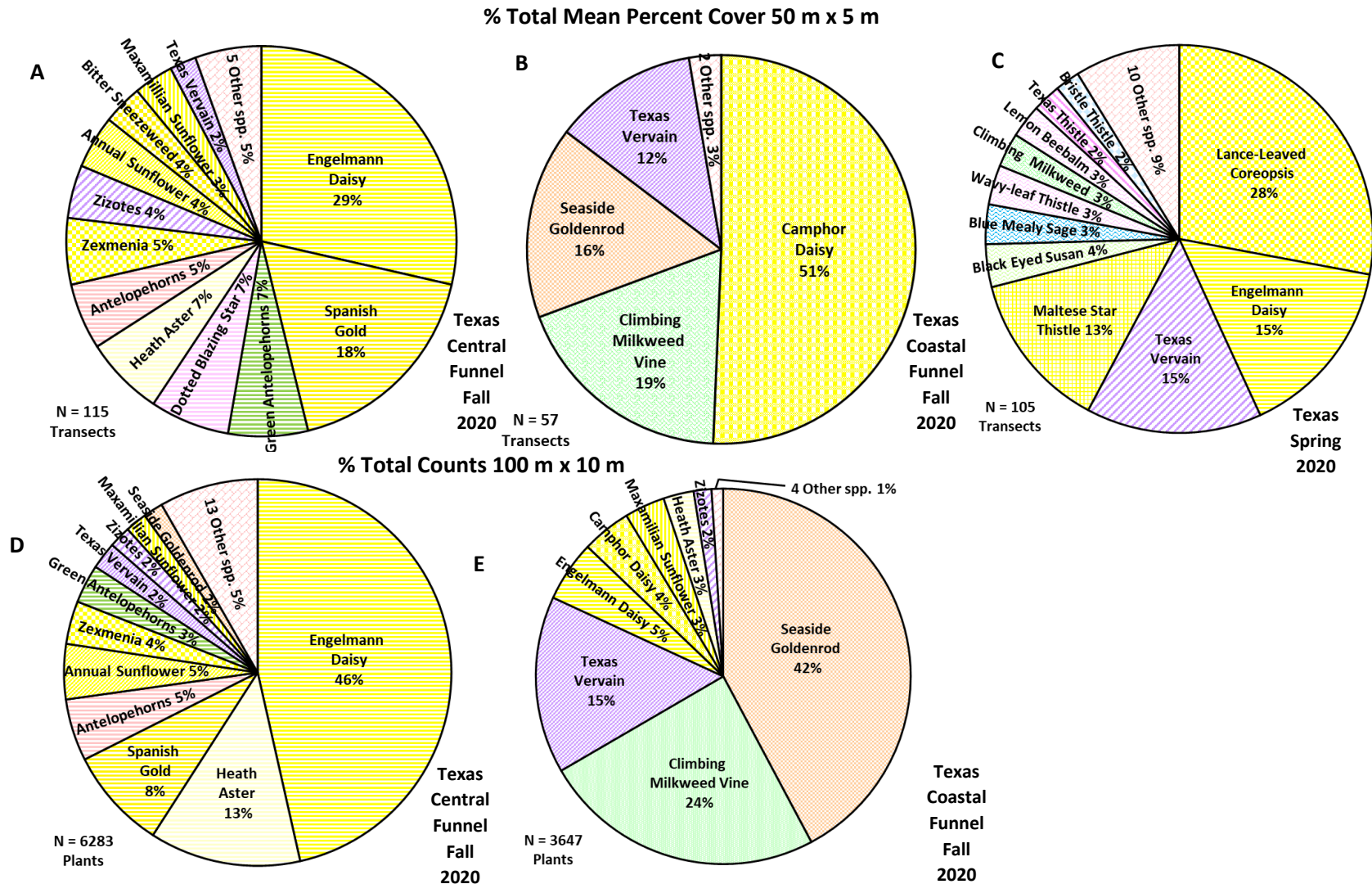
**Figure 18. Distribution of fall 2020 milkweed plants per 100m x 10 m transect (unthinned) in Texas monarch migratory Central Funnel and eastwards: (A) All milkweeds; (B) Antelopehorn; (C) Green antelopehorns; (D) Zizotes milkweed; (E) Broadleaf milkweed; and (F) Other milkweeds (symbols ca. proportional among taxa).**



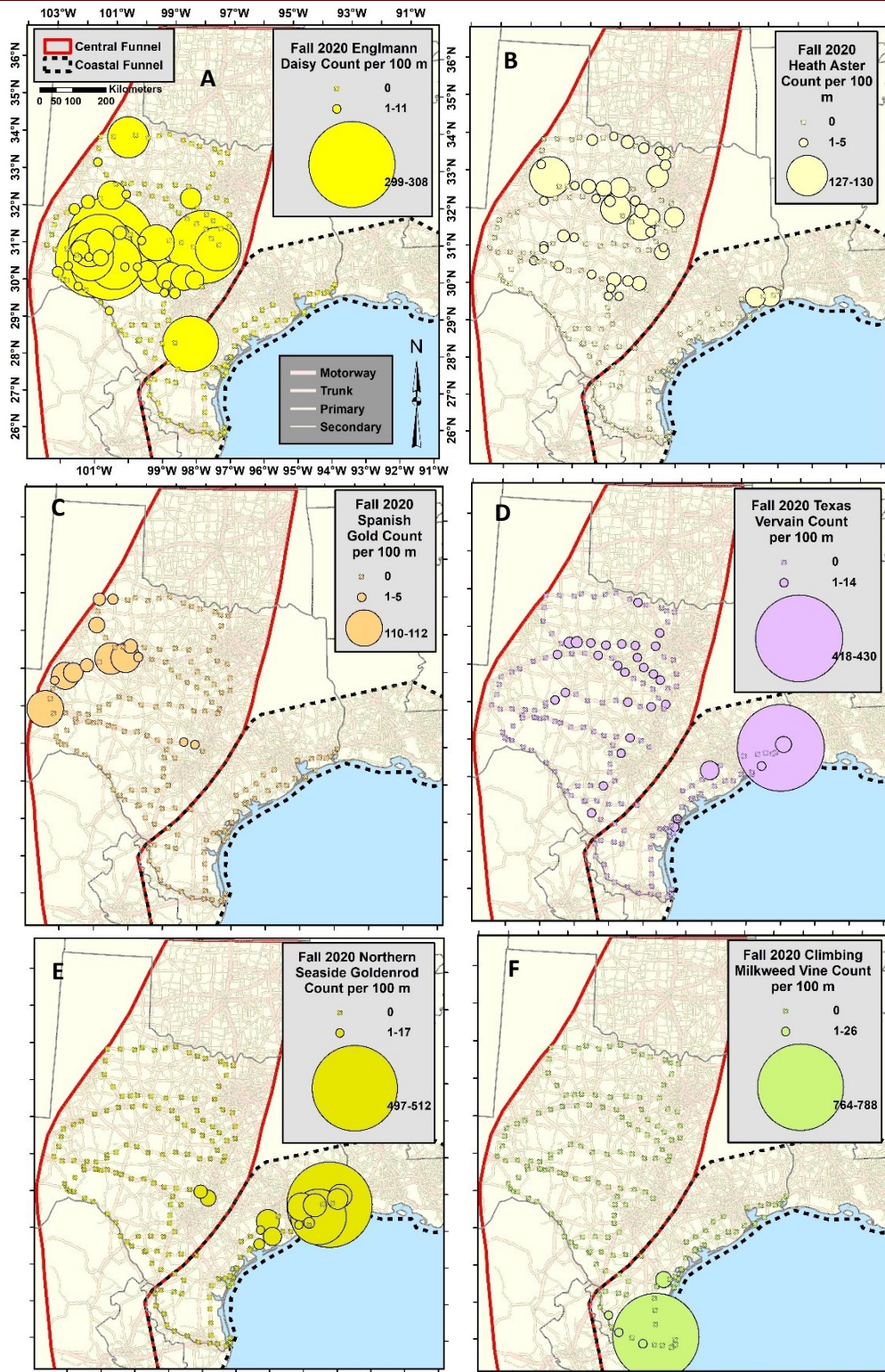


**Figure 19. Major October-December 2020 native roadside monarch preferred nectar plants (including top four milkweed larval hosts) in Texas: (A) Engelmann daisy, *Engelmannia peristenia*; (B) Heath aster, *Symphyotrichum ericoides*; (C) Spanish gold, *Grindelia ciliata*; (D) antelopehorns, *Asclepias asperula* ssp. *capricornu*; (E) Northern seaside goldenrod, *Solidago sempervirens*; (F) Climbing milkweed vine, *Funastrum cynanchoides*; (G) Texas vervain, *Verbena halei*; (H) green antelopehorns, *A. viridis*, (I) Annual sunflower, *Helianthus annuus*; (J) Maximilian sunflower, *Helianthus maximiliani*; (K) Zizotes milkweed, *A. oenotheroides*; (L) Broadleaf milkweed, *A. latifolia* (images, iNaturalist 2021).**



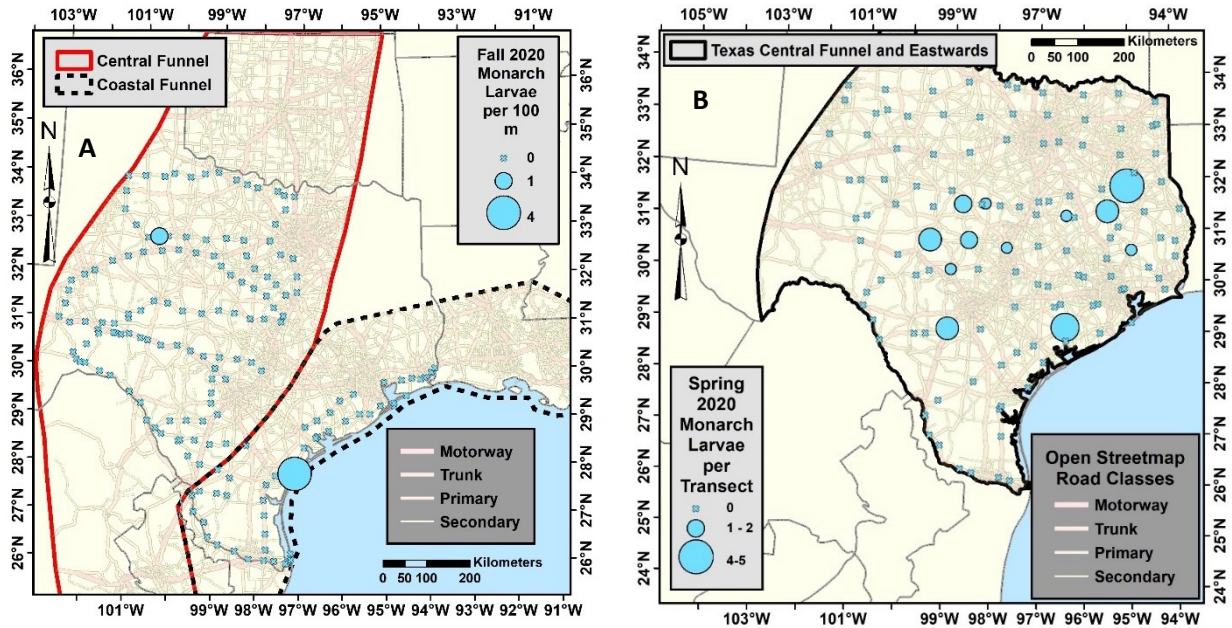


**Figure 20. Percentages of monarch preferred nectar plants in roadside transects: (A-C) Percent of mean % cover along 50 m x 5 m roadside transects for (A-B) Texas Central (A) and Coastal (B) funnels, Oct-Dec 2020 (Table 8); and (C) Texas, Apr-May 2020 (Tracy et al. 2020c); and (D-F) Percentages of total counts among all 100m x 10 m transects for (A-B) Texas Central (A) and Coastal (B) funnels, Oct-Dec 2020 (data not shown).**



**Figure 21. Fall 2020 counts of monarch-preferred nectar plants per 100m x 10m transect (unthinned) in Texas monarch migratory Central and Coastal funnels: (A) Engelmann Daisy, (B) Heath Aster, (C) Spanish Gold; (D) Texas Vervain; (E) Northern Seaside Goldenrod; and (F) Milkweed Vine (symbols independent when maximum  $\geq 308$ ; symbols ca. proportional among other taxa) (see Table A3 for additional maps).**





**Figure 22. Distribution of fall (A) and spring (B) 2020 numbers of monarch larvae in Texas roadside transects. Two (adventitious) versus 12 (two adventitious and ten dispersed) total transects with larvae in the fall and spring, respectively.**

## References

- Geofabrik (2017) OpenStreetMap Data Extracts. Accessed at: <http://download.geofabrik.de/>
- Halbritter, D.A., Daniels, J.C., Whitaker, D.C. and Huang, L. 2015. Reducing mowing frequency increases floral resource and butterfly (Lepidoptera: Hesperioidea and Papilionoidea) abundance in managed roadside margins. *Florida Entomologist*, 98(4):1081-1092.
- iNaturalist. 2021. *Observations*. Accessed at: <https://www.inaturalist.org/observations/>
- Kantola, T., Tracy, J.L., Baum, K.A., Quinn, M.A., and Coulson, R.N. 2019. Spatial risk assessment of eastern monarch butterfly road mortality during autumn migration within the southern corridor. *Biological Conservation*, 231:150-160.
- McKenna, D.D., McKenna, K.M., Malcom, S.B., and Berenbaum, M.R. 2001. Mortality of Lepidoptera along roadways in central Illinois. *Journal of Lepidopterists' Society*, 55 (2): 63-68.
- Monarch Watch. 2021. Monarch Population Status. *Monarch Watch Blog*, 25 February 2021. Accessed at <https://monarchwatch.org/blog/2021/02/25/monarch-population-status-45/>
- Scott JA (1992) *The butterflies of North America: a natural history and field guide*. Stanford University Press, Stanford, California.
- Tracy J.L., and Coulson R.N. 2019. *Eastern Monarch Butterfly Fall Migratory Roadkill Distribution and Hotspot Regions within the Coastal and Central Migratory Funnels of Texas*. Texas A&M Department of Entomology/Texas Transportation Institute Project Final Report. TxDOT Environmental Affairs Division, Austin, Texas. 32 pp. Available at: [https://www.dropbox.com/s/an9wuzkyr54xdb0/TTI\\_TAMU%20Texas%20Monarch%20Roadkill%20Fall%202018%20Report.docx?dl=0](https://www.dropbox.com/s/an9wuzkyr54xdb0/TTI_TAMU%20Texas%20Monarch%20Roadkill%20Fall%202018%20Report.docx?dl=0)
- US Department of Transportation, Federal Highway Administration (USDOT-FHWA). 2013. *Highway Functional Classification Concepts, Criteria and Procedures*. Accessed at: [https://www.fhwa.dot.gov/planning/processes/statewide/related/highway\\_functional\\_classifications/fcauab.pdf](https://www.fhwa.dot.gov/planning/processes/statewide/related/highway_functional_classifications/fcauab.pdf)
- USDOT-FHWA. 2020. *HPMS [Highway Monitoring Performance System] Public Release of Geospatial Data in Shapefile Format*. Polyline shapefiles for US states for 2017



including AADT and Traffic Speed. Accessed at:

<https://www.fhwa.dot.gov/policyinformation/hpms/shapefiles.cfm>

US Geological Survey [USGS]. 2017. *National Hydrography Dataset Plus High Resolution (NHDPlus HR) – USGS National Map Downloadable Data Collection*. Accessed at:

<https://apps.nationalmap.gov/viewer/>

## Appendix

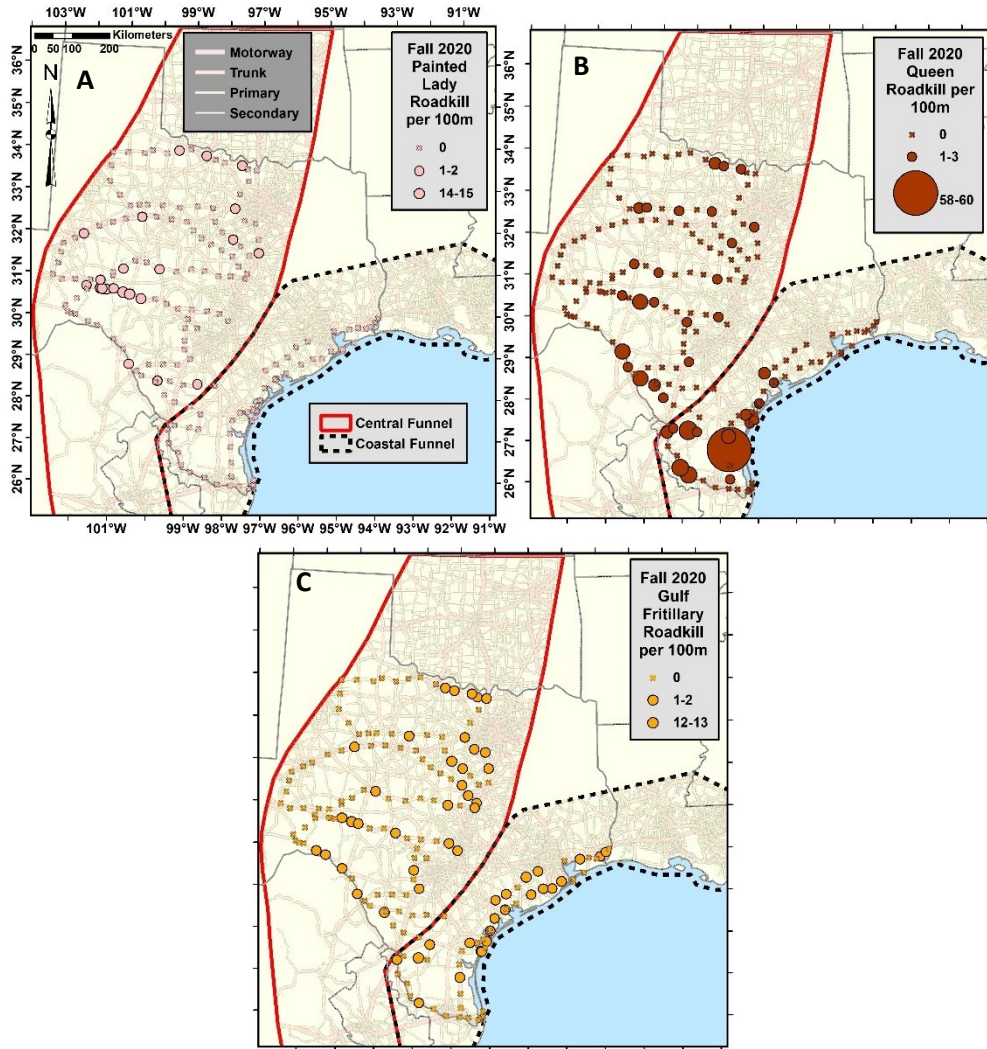
**Table A1. Lepidoptera and Hymenoptera roadkill spatial correlations ( $r_s$ ) with monarch preferred nectar plants for fall 2020 in monarch fall migratory Central and Coastal funnels of Texas for 100m transects.<sup>a</sup>**

Species Roadkill	Central Funnel (n = 115)	Coastal Funnel (n = 55)
<i>Correlation with Milkweed Plant Count in 100 x 10 m transects<sup>c</sup></i>		
Lepidoptera	0.07	-0.02
Hymenoptera	-0.05	0.28*
Honey Bees	0.04	-0.06
Native Bees	-0.009	0.31*
<i>Correlation with Non-Milkweed Nectar Plant Count in 100 x 10 m transects<sup>b</sup></i>		
Lepidoptera	-0.03	-0.05
Hymenoptera	-0.07	0.08
Honey Bees	-0.08	0.09
Native Bees	0.13	0.08

<sup>a</sup>Asterisks indicate significant correlation ( $P < 0.05$ ; paired Spearman rank order correlations with Holm’s correction for multiple comparisons per migratory funnel and correlation group subheading) (See Figure 16 for graphs of significant correlations).

<sup>b</sup>Includes dispersed and adventitious transects.

<sup>c</sup>Includes dispersed, adventitious, and random dispersed transects.



**Figure A1. Distribution of fall 2020 roadkill per 100m x 1m transect (unthinned) for Lepidoptera taxa in Texas monarch migratory Central and Coastal funnels: (A) Painted Lady; (B) Queen; and (C) Gulf Fritillary (symbols ca. proportional among taxa).**

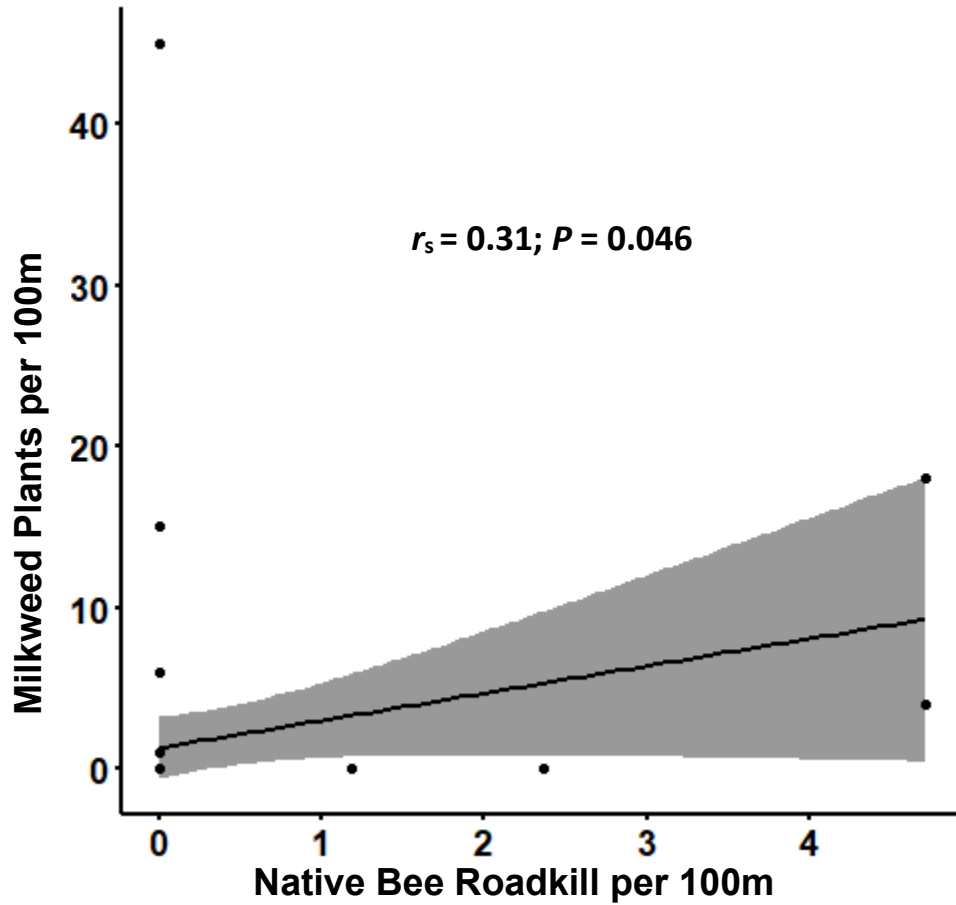
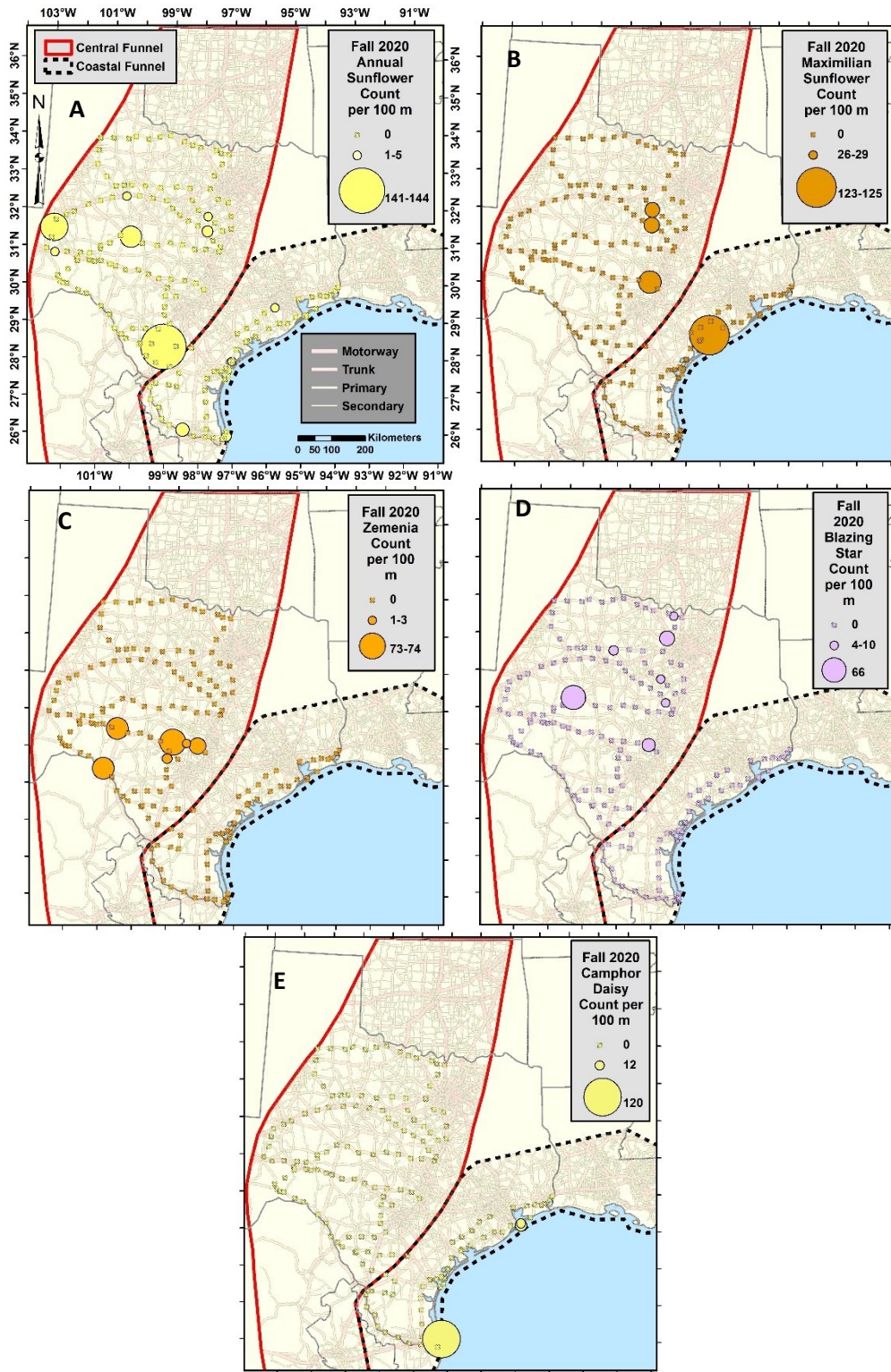


Figure A2. Spearman’s rank order correlation ( $r_s$ ) between Coastal Funnel native bee roadkill and milkweed plants (Holm’s adjusted  $P$ -values; see Table 3).





**Figure A3. Fall 2020 counts of monarch-preferred nectar plants per 100m x 10m transect (unthinned) in Texas monarch migratory Central and Coastal funnels: (A) Annual Sunflower, (B) Maximilian Sunflower, (C) Zexmenia; (D) Blazing Star (*Liatris* spp.); and (E) Camphor Daisy (symbols at maximum range for plants with maximum count over 308; symbols ca. proportional among other taxa).**

## CHAPTER 5. SPRING 2021 MONARCH AND ARTHROPOD ROADKILL AND ROADSIDE MILKWEEDS AND NECTAR PLANTS

### Summary

Monarch roadkill in the monarch migratory Central Funnel and eastwards in Texas for spring 2021 was estimated at 192,587. This estimate is very similar to the 190,240 monarch roadkill estimated for spring 2020, about 43% of the 448,373 estimated Texas roadkill in the fall of 2019, and much lower than the 2-14 million estimated killed during the fall in Texas from 2016-2020. Spring 2021 arthropod roadkill in the Texas Central Funnel and eastwards was estimated at about 7.7 million, about half that of the 14.5 million estimated for spring 2020, and much lower than the 19 million of fall 2020. Pollinators comprised 63% of spring 2021 roadkill, compared to 75% for spring 2020. Lepidoptera representing 28% of arthropod roadkill for spring 2021 was much lower than 66-86% for fall 2019 and 2020. Monarch and lepidoptera roadkill were not significantly correlated with milkweed density or percent cover of monarch-preferred nectar plants. Monarchs composed 9% of the Lepidoptera roadkill in spring 2021, compared to 3% in spring 2020, and 19% and 32% for the fall 2020 and 2019, respectively. Orange sulphurs, variegated fritillaries, monarchs, painted ladies, red admirals, goatweed butterflies, hackberry butterflies, and question marks comprised most of the spring Lepidoptera roadkill. Green antelopehorn comprised 44% of the spring 2021 milkweed roadside plants counted, and antelopehorns dominated 57% of the milkweed stems counted. Several roadside milkweed hotspots ranging from 40 to 258 plants per 100 meters were found for the three major species, green antelopehorn, antelopehorns, and zizotes milkweed. Roadside milkweed densities averaged about 87 per hectare, with milkweeds occurring in 40% of random dispersed transects. Dominant spring 2021 nectar plants included widely distributed Texas vervain and lemon beebalm, and regional stands of Engelmann daisy and lance leaved coreopsis, similar to what was observed for spring 2020. Milkweeds and golden crownbeard were the only very high value monarch spring roadside nectar plants found. Four percent of dispersed transects had monarch larvae with an average density of 0.02 to 0.06 per plant for the three common milkweed species. A significant but weak correlation was found between roadside monarch larvae per hectare and number of milkweed plants per hectare in both the spring of 2021 and 2020. These data can inform regional planning of spring monarch roadside milkweed and nectar plant conservation activities as compensatory mitigation for monarch road mortality during the fall migration.

## Methods

Roadkill observations over dispersed, random dispersed, and adventitious transects across the Texas Central Funnel and eastwards (Fig. 1) were made by a two-person team following the same protocol as Kantola et al. (2019). Roadkill data was primarily obtained from 100 x 1 meter dispersed transects that were spaced about every 80 km (50 mi), instead of 20-30 km, to cover a wider area during the spring migration. The general protocol for collection of roadside milkweeds, monarch-preferred nectar plant, monarch larval data, and live roadside monarch adults follows that of fall 2020 observations (Part II Chapter 4) (Fig. 2-4). Additional data recorded for random dispersed transects in spring 2021 includes counts of monarch-preferred nectar plants in addition to milkweeds.

## Results and Discussion

### *Arthropod Roadkill*

Estimated spring 2021 arthropod roadkill per transect was not significantly different among the four main road classes examined in this study (Table 1), but additional data obtained from a fifth road class (Open Street Map Tertiary roads, such as FMs), had significantly lower roadkill than Motorways. Consequently, data are pooled among the four main highway types and tertiary roadkill data is omitted for estimating total roadkill. Estimated Texas monarch roadkill of 192,587 for spring 2021 was slightly higher than the 190,240 found for spring 2020 (Table 2), and it represents about 32% of the estimated minimum 590,000 monarch roadkill for fall 2019 in the Central and Coastal funnels, which was the minimum estimated fall roadkill from 2018-2020. Estimated total arthropod roadkill in the spring of 2021 for the Texas Central Funnel/East Texas region was estimated at 7.3 million (Table 2), about half of that seen in spring 2020 14.5 million (Part II Chapter 3). Spring arthropod road mortality for both years is much higher than the combined totals of 1.9 million from the Texas Central and Coastal funnels in the fall of 2019 (Part II Chapter 2). Texas Lepidoptera roadkill was estimated at 2 million for spring 2021, compared to 7.7 million for the spring 2020 (Part II Chapter 3), 19 million for fall 2020 (Part II Chapter 4), and 1.9 million for fall 2019 (Part II Chapter 2).

Monarchs comprised 9% of the spring 2021 Lepidoptera roadkill (Table 2) compared to only 3% of the spring 2020 (Part II Chapter 3), and 19% and 32% of the fall 2020 and 2019 Lepidoptera roadkill, respectively (weighted average from Central and Coastal funnels; Part II Chapters 3-4). The 3-9% value for monarch spring roadkill is similar to the lower percentages of Lepidoptera roadkill comprised of monarchs during the fall in Illinois (5%; McKenna et al. 2001) and from spring through fall in Florida (3%; Halbritter et al. 2015) (see Fig. 4 of Part II Chapter 2).

Lepidoptera made up only 28% of spring 2021 arthropod roadkill compared to 53% of spring 2020 arthropod roadkill. The spring 2020 and 2021 Lepidoptera roadkill percentages are much lower than our observed 66-86% fall 2019 and 2020 roadkill in the Texas Central and Coastal funnels (Fig. 5). The 28% Lepidoptera portion of spring 2021 arthropod roadkill is closer to the low proportions of Lepidoptera roadkill among arthropods found in several other studies in North America and Europe (Part II Chapter 2). Spring 2021 Lepidoptera roadkill counts per transect of 9.57 per 100 m (Table 2) were similar to the 10.05 per 100 m observed for spring 2020 (Part II Chapter 3). As with spring 2020 roadkill, much greater proportions of Coleoptera and Hymenoptera with lower proportions of Orthoptera were found in spring 2021 roadkill compared to fall roadkill (Fig. 5).

Dominant species in spring 2021 Lepidoptera roadkill were orange sulphurs, variegated fritillaries, monarchs, painted ladies, red admirals, goatweed butterflies, hackberry butterflies, and question marks (Figs 6-7). Pieridae roadkill only represented 39% of spring 2020 Lepidoptera roadkill compared to 48% in spring 2020 (Fig. 6). Orange sulphurs dominated both spring 2021 and spring 2020 Lepidoptera roadkill, followed by various Nymphalidae, including variegated fritillaries (Fig. 6). Buckeyes had much lower percent roadkill in spring 2021 compared to spring 2020, while variegated fritillaries had higher roadkill in spring 2021 (Fig. 6.)

Arthropod roadkill hotspots were smaller in spring 2021 compared to spring 2020 and fall 2020, when greater Lepidoptera roadkill dominated the hotspots (Figs. 8-9) (Part II Chapters 3-4). Lepidoptera roadkill was broadly distributed, but generally less frequent to the extreme west (Figs. 9-10). The largest arthropod roadkill hotspot (61 roadkill) was on US-84 east of Evant (Fig. 11A). A maximum of seven roadkill monarchs per transect were found in the spring 2021 (Fig. 10C) at Port Lavaca (Fig. 11B), compared with a maximum of four monarch roadkill per site in spring 2020 (Part II Chapter 3). The low monarch roadkill densities in the spring of 2021 and 2020 (Part II Chapter 3) showed little regional variation compared to the localized regions of hotspots seen in fall 2019 (Part II Chapter 2) and 2020 (Part II Chapter 3) (Fig. 12).

The occurrence of monarch roadkill was significantly weakly correlated with roadkill of the three of the four most common roadkill lepidopteran species, orange sulphurs, variegated fritillaries, and painted ladies, with  $r_s$  values ranging from 0.18 to 0.2 (Table 3). These correlations were much lower than moderate correlations seen in spring 2020 with  $r_s$  values of 0.39 to 0.43 (Part II Chapter 3). Overall spring 2021 correlation of monarch roadkill to roadkill of all other Lepidoptera was also significantly weak, with an  $r_s$  of 0.35, similar to that of spring 2020 (Fig. 13A-B). In contrast, fall 2020 monarch roadkill was only very weakly significantly correlated with that of other Lepidoptera (Fig. 13C).



## Roadside Milkweeds

Numbers of milkweed plants per transect in spring 2021 did not significantly differ among road classes or by distance to road edge (0-5 m versus 5-10 m) and were pooled for comparisons and extrapolations (Tables 1,4). About 40% and 43% of the random dispersed and dispersed transects had milkweeds in spring 2021, respectively (Table 5). These percentages are slightly lower than the 47% of dispersed transects with milkweeds in spring 2020 (Part II Chapter 3), and similar to the 36% and 40% of random dispersed and dispersed transects with milkweeds in fall 2020, respectively (Part II Chapter 4). Even though milkweed were searched for about every 80 km in the dispersed transects, the percentages of transects with milkweeds similar to that in random dispersed transects, matching the pattern seen in fall 2020 (Part II Chapter 4). Percentages of transects with milkweeds in spring 2020 and 2021 and fall 2020 are all much lower than the 71-82% of roadside plots with common milkweed (*A. syriaca*) in Iowa (Hartzler and Buhler 2000, Hartzler 2010) and lower than 60% of roadside transects with milkweeds (97% *A. syriaca*) in the Upper Midwest (Kasten et al. 2016). The density per hectare of milkweeds in spring 2021 ranged from 87 to 134 in random dispersed and dispersed transects, respectively (Table 5). These densities are 32%-49% of the 274 common milkweed per hectare found in roadsides of the Upper Midwest (Kasten et al. 2016). However, spring 2021 roadside milkweed densities are much higher than the 38 milkweeds per hectare estimated for roadsides in Iowa (Pleasants and Oberhauser 2013), and 36 common milkweed stems per hectare in Iowa for unplanted roadsides (Kaul and Wilsey 2019) (common milkweeds typically have one stem per plant; Singhurst et al. 2015).

The proportion of milkweed plants in all transects was dominated by green antelopehorn at 44%, followed by 31% antelopehorns, 13% zizotes milkweeds, 8% slim milkweed, 1% butterflyweed, 1% green comet milkweed, and 1% other milkweeds (Table 6, Figs. 14A, 15). Other milkweeds found include Engelmann's milkweed, Emory's milkweed, clasping milkweed, a species similar to narrowleaf milkweed, broadleaf milkweed, and whorled milkweed (Table 6, Fig. 2). The mean stems per plant was greatest for antelopehorns (Table 6), giving it the highest proportion of 57% of all milkweed stems (Fig. 14C). Counts of milkweed plants per roadside transect for green antelopehorns, antelopehorns, and zizotes milkweed (Table 5) were very similar to that observed in spring 2020 (Part II Chapter 3), but about twice that observed in fall 2020 (Part II Chapter 4). The number of stems per antelopehorns was significantly lower in Northeast Texas, compared to its primary range in the Central and Coastal funnels, and the length of the longest antelopehorns stem was longer in Northeast Texas compared to the Coastal Funnel (Table 7). Green antelopehorns had significantly higher numbers of stems in the Central Funnel compared to the Coastal Funnel, with stems significantly longer in Northeast Texas, compared to other regions, and longer in the Central Funnel, compared to the Coastal Funnel (Table 7).

Roadside milkweed densities were significantly highest in the Central Funnel, followed by the Coastal Funnel, with lowest densities in northeast Texas (Figs. 1, Table 8, Fig. 16). The two dominant roadside milkweeds, green antelopehorn and antelopehorns, had the highest densities in the eastern and western portions of the survey area, respectively (Fig. 16 B-C). *Zizotes* milkweed was the most frequent roadside milkweed in South Texas, and the only common species in the southern Rio Grande Valley (Fig. 16D). Several other roadside milkweed species were distributed across the Central Funnel (Figs. 16E-F). The later season blooming broadleaf of West Texas was rare in the spring 2021 survey. Several hotspots of milkweed occurrence with more than 40 plants per transect were found among the top three milkweed species (Figs. 3A, 16B-D), some of which were along interstate highways (Fig. 17). Hotspots of common milkweeds in spring 2021 were a little more broadly distributed than in spring 2020 (Part II Chapter 3), and both spring 2021 and 2020 hotspots were much larger than in fall 2020, when they were primarily in the northeastern Central Funnel (Part II Chapter 4) (Fig. 18).

Similar to results from spring and fall 2020, there was no significant correlation between numbers of milkweed plants per transect and number of Lepidoptera roadkill in spring 2021 (Fig. 19). There was also no significant correlation between monarch roadkill and milkweed plants in spring 2021, in contrast to significantly weak correlations in spring 2020 and fall 2020 (Fig. 20). In both spring 2021 and fall 2020, there was no significant correlation between monarch roadkill and non-milkweed nectar plants (Fig. 21).

### *Roadside Monarch Preferred Nectar Plants*

Non-milkweed monarch preferred nectar plant percent cover and counts for spring 2021 did not differ among road classes or distance to road edge (Tables 1,4), and data were pooled across road classes for analyses (Tables 9-10). Twenty-one species of monarch preferred nectar plants had at least one percent cover in our dispersed transects, of which two were exotic, Maltese Star-thistle and Brazilian vervain (Table 9). Four native species generally comprised the greatest percentage of monarch preferred nectar plants across the transects using a variety of measures of percent frequency: Engelmann daisy, Texas vervain, lance leaved coreopsis, and lemon beebalm (Tables 9-10, Figs. 22-23). These species generally correspond to the most common spring 2020 non-milkweed nectar plants (Part II Chapter 3, Fig. 22). Other common spring 2021 nectar plants included lyreleaf sage, slender vervain, prairie verbena and climbing milkweed vine (Figs. 22-23). In contrast to spring 2020 when Texas thistle represented about 7% of percent cover in transects (Part II Chapter 3), Texas thistle represented less than 1% of percent cover in spring 2021. Monarch preferred spring nectar plants occurred in about 83 and 87% of the dispersed and random dispersed transects, respectively, with densities averaging around 1,990 and 2,201 nectar plants per hectare (Table 5).

Monarch preferred spring nectar plants were widely distributed throughout roadsides of the Texas Central Funnel/East Texas study area (Figs. 24-26). Monarch spring nectar plant hotspots were more widely distributed in spring 2021 (Fig. 24A), compared to spring 2020 (Part II Chapter 3). The most widely distributed spring 2021 common nectar plants were Texas vervain, prairie verbena, and lemon beebalm (Fig. 22C,E,F). Engelmann daisy was widely distributed in the Central Funnel, and portions of the middle Coastal Funnel (Fig. 24B). Common nectar species that were important regionally, included lance leaved coreopsis in the northern Coastal Funnel and northeast Texas, slender vervain in the northern Coastal Funnel, other *Verbena* spp. in the southern Central Funnel, and climbing milkweed vine and golden crownbeard in the southern Coastal Funnel (Figs. 24-25). Common immature summer/fall monarch preferred nectar plants included widely distributed annual sunflower, goldenrod along the northeastern coast, and black-eyed susan in the northern Coastal Funnel and northeast Texas (Fig. 26). Spring 2021 nectar plants also common in the fall 2020 were Engelmann daisy, Texas vervain, and climbing milkweed vine (Part II Chapter 4).

### Roadside Monarchs

No significant differences were seen in spring 2021 numbers of monarch larvae per milkweed plant in the inner 0-5 m transects compared to the outer 5-10 m transects (Table 4), and data were pooled across inner and outer transects. Mean monarch larvae per plant per transect ranged from 0.02 to 0.06 and did not significantly differ among the three common milkweeds of green antelopehorn, antelopehorns, and zizotes milkweed (Table 11). These spring 2021 numbers of larvae per plant are comparable to the 0.02 monarch larvae found per roadside milkweed plant in the Upper Midwest (Kasten et al. 2016). Four percent of the 196 dispersed transects had monarch larvae in spring 2021 compared to nine percent of 106 dispersed transects in spring 2020 (Part II Chapter 3). The only other milkweed species with monarch larvae were green comet milkweed and slim milkweed. Numbers of monarch larvae per antelopehorns plant per transect were significantly higher in northeast Texas compared to other regions (Table 7). Numbers of monarch larvae per milkweed plant did not significantly differ across regions for green antelopehorns and zizotes milkweed (Table 7).

Roadside monarch larval density per hectare was highest in the Coastal Funnel and northern portion of the Central Funnel in spring 2021, and densities reached higher values than seen in spring 2020 (Fig. 27). The relative abundance of roadside monarch larvae on different milkweed species in spring 2021 was similar to that of spring 2020 (Fig. 28), and corresponded more closely to the relative abundance of milkweed stems rather than the relative abundance of milkweed plants per species (Fig. 14A-B). Some monarch larvae were found on milkweed very close to the paved or gravel shoulder, such as along FM-574 west of Goldwaithe (Fig. 3C-E).

A significant but weak correlation was found between both (1) the roadside monarch larvae per hectare and (2) the monarch larvae per plant versus the number of milkweed plants per hectare in both the spring of 2021 and 2020 (Fig. 29). Significant but very weak correlations were found between the number of monarch larvae per plant and both the number of milkweed stems per plant and the length of the longest stem per milkweed plant for green antelopehorns (Fig. 30).

A faded remigrant monarch adult was photographed ovipositing on roadside green antelopehorn on US-59 near El Campo, Texas on 26 March (Fig. 2A-B). Another faded remigrant monarch was photographed nectaring on indian paintbrush along TX-257 at Galveston Island, 23 March (Fig. 2C). Paintbrushes are generally considered poor quality nectar sources for monarchs (Chip Taylor, Monarch Watch, Kansas, pers. comm.), but they can be valuable in early spring where other nectar sources are sparse (Carol Clark, Monarch Watch, Texas, pers. comm.). We regard paintbrushes as a medium quality nectar source for monarch, contrasted with the high to very high quality value ascribed to other nectar plants discussed in this report

## Conclusion

An estimated 192,587 monarch roadkill occurred in the spring of 2021 throughout the Texas Central Funnel/East Texas survey area. About 7.3 million arthropod roadkill were estimated for 2021, which was about half that seen in spring 2020. Pollinators (Lepidoptera and Hymenoptera) represented 63% of the arthropod roadkill in spring 2021, compared with 75% in spring 2020. Monarch roadkill represented only 9% of Lepidoptera roadkill in the spring of 2020 compared to 3% in spring 2020 and 32% in the fall of 2019. We found no correlation between Lepidoptera or monarch roadkill and either numbers of milkweed per transect or percent cover of monarch-preferred nectar plants in spring 2021. Texas spring 2021 roadside milkweeds were dominated by green antelopehorn and antelopehorns, with zizotes milkweed being locally dominant in South Texas. Roadside milkweed densities were greatest in the Central Funnel, followed by the Coastal Funnel, and Northeast Texas. Some regional differences were also seen in milkweed stem count and length and larval presence for certain milkweeds. Milkweed roadside hotspots were identified for the three dominant species. Monarch preferred nectar plants in spring 2021 were dominated by Engelmann daisy, Texas vervain, lance leaved coreopsis, and lemon beebalm, but the very high value monarch nectar species were represented only by the three major milkweeds, green antelopehorn, antelopehorns, and zizotes milkweed, and golden crownbeard. Texas vervain, prairie verbena, and lemon beebalm were the most widespread common monarch nectar species. Several monarch nectar plants were important only in certain regions, such as lance leaved coreopsis, Engelmann daisy, slender vervain, climbing milkweed vine, and golden crownbeard. The added counts of non-milkweed plants in random dispersed transects provided significant additional information on roadside nectar plant



distribution and density. A significant but weak correlation was found between roadside monarch larvae per hectare and number of milkweed plants per hectare in both the spring of 2021 and 2020. Information on the roadside distribution and relative abundance of milkweeds and nectar plant species is valuable in planning compensatory mitigation to benefit monarchs and other Texas pollinators.

## Tables

**Table 1. Arthropod roadkill, milkweed plants for 100 m x 5 m transects, percent cover of nectar plants for 50 m x 5 m transects, and kilometer roadway length by Open Street Map (OSM) road classes (with corresponding Federal Highway Administration, FHWA, road classifications) for March-May 2021 in Texas for monarch migratory Central Funnel and eastwards.**

Unit	Estimates per 100 m Transect (Mean ± SD) by OSM Road Classification (Major Corresponding FHWA Road Classes) <sup>a</sup>					Overall <sup>b</sup>
	Motorway (60% Interstate; 26% Other Freeways and Expressways)	Trunk (83% Other Principal Arterials; 11% Minor Arterials)	Primary (43% Minor Arterials; 32% Other Principal Arterials)	Secondary (37% Major Collectors; 12% Minor Arterials)	Tertiary (Major Collectors)	
<i>Arthropod Roadkill (100m x 1m transects, unthinned data)<sup>a,c</sup></i>	9.74 ± 10.79 (36)a	8.97 ± 12.15 (85)ab	7.40 ± 11.11 (71)ab	7.38 ± 11.77 (9)ab	1.79 ± 3.02 (8)bc	8.48 ± 11.49 (201)
<i>Milkweed Plant Counts (Inner and Outer 100 x 5 m Transects)<sup>d</sup></i>	16.82 ± 45.77 (55)a	7.54 ± 20.26 (125)a	5.18 ± 13.21 (106)a	26.75 ± 86.88 (16)a	24.17 ± 70.41 (12)a	9.42 ± 31.87 (302)
<i>Other Monarch-Preferred Nectar Plant Counts (Inner and Outer 100 x 5 m Transects)<sup>d</sup></i>	106.55 ± 160.66 (55)a	78.38 ± 201.10 (125)a	109.81 ± 216.91 (106)a	87.31 ± 142.40 (16)a	60.25 ± 67.00 (12)a	95.01 ± 197.32 (302)
<i>Milkweed Plant Percent Cover (50m x 1m transects)<sup>c</sup></i>	0.11 ± 0.40 (36)a	0.06 ± 0.28 (85)a	0.10 ± 0.30 (71)a	0.22 ± 0.44 (9)a	0.00 ± 0.00 (8)a	0.09 ± 0.32 (201) <sup>c</sup>
<i>Nectar Plant Percent Cover (50m x 1m transects)<sup>c</sup></i>	4.00 ± 10.48 (36)a	1.56 ± 5.08 (85)a	1.20 ± 3.23 (71)a	0.33 ± 0.71 (9)a	0.38 ± 0.74 (8)a	1.81 ± 5.90(201) <sup>c</sup>
<i>Roadways</i>	Roadway Lengths (km)					
	7,372	11,358	23,340	34,026	--	76,096

<sup>a</sup>Means in the same row with the same letter are not significantly different (P < 0.05; Kruskal-Wallis test) (For further details on correspondence of OSM (Geofabrik 2017) and FHWA road classes (USDOT FHWA 2013, 2020), see Part II Chapter 3, Table A2).

<sup>b</sup>Overall value does not include Tertiary roads.

<sup>c</sup>Data from Dispersed and Adventitious transects.

<sup>d</sup>Data from Dispersed, Adventitious, and Random Dispersed transects.

**Table 2. Arthropod 100 m x 1 m transect roadkill counts (includes extrapolations to uncounted sides) for various taxa in spring 2021 monarch migratory Central Funnel and eastwards.<sup>a</sup>**

Taxa/Species	Roadkill Counts (Percent of Taxa)	Roadkill per 100m x 2m Transect (Mean $\pm$ SD) (n = 124 transects)	Estimated Total Roadkill = (Estimated Roadkill per 100m x 2m) x 10 transects/km x Km Length Highways <sup>b</sup>
<i>Arthropods</i>	1,924	9.57 $\pm$ 12.78 (125)	7,284,545
Lepidoptera	542 (28%)	2.63 $\pm$ 4.93	1,999,280
Coleoptera	651 (34%)	3.24 $\pm$ 5.45	2,465,170
Hymenoptera	671 (35%)	3.34 $\pm$ 5.61	2,543,272
Odonata	35 (2%)	0.17 $\pm$ 0.67	131,445
Orthoptera	25 (1%)	0.12 $\pm$ 0.50	93,548
Diptera	3 (<1%)	0.02 $\pm$ 0.17	12,645
Hemiptera	7 (<1%)	0.03 $\pm$ 0.25	26,539
Arachnida	3 (<1%)	0.02 $\pm$ 0.17	12,645
<i>Lepidoptera Taxa</i>			
<i>Nymphalidae</i>	286 (52%)	1.42 $\pm$ 3.03	1,081,510
Variegated Fritillary ( <i>Euptoieta claudia</i> )	83 (15%)	0.41 $\pm$ 1.21	313,167
Monarch ( <i>Danaus plexippus</i> )	51 (9%)	0.25 $\pm$ 0.80	192,587
Painted Lady ( <i>Vanessa cardui</i> )	31 (6%)	0.16 $\pm$ 0.60	117,892
Red Admiral ( <i>Vanessa atalanta</i> )	29 (5%)	0.14 $\pm$ 0.71	108,957
Goatweed Butterfly ( <i>Anaea andria</i> )	25 (5%)	0.12 $\pm$ 0.41	93,511
Emperors (Apaturinae sp.)	25 (5%)	0.12 $\pm$ 1.58	93,132
Question Mark ( <i>Polygonia interrogationis</i> )	16 (3%)	0.08 $\pm$ 0.43	61,861
Buckeye ( <i>Junonia coenia</i> )	11 (2%)	0.05 $\pm$ 0.45	40,585
Common Snout Nose ( <i>Libytheana carinenta</i> )	5 (1%)	0.02 $\pm$ 0.17	17,869
Viceroy ( <i>Limenitis archippus</i> )	4 (1%)	0.02 $\pm$ 0.14	13,402
Checkerspot ( <i>Chlosyne</i> sp.)	4 (1%)	0.02 $\pm$ 0.14	26,542
Gulf Fritillary ( <i>Agraulis vanillae</i> )	2 (<1%)	0.01 $\pm$ 0.14	7,572
Queen ( <i>Danaus gilippus</i> )	2 (<1%)	0.01 $\pm$ 0.14	7,572
<i>Pieridae</i>	213 (39%)	1.06 $\pm$ 2.60	805,406
Orange Sulphur ( <i>Colias eurytheme</i> )	194 (36%)	0.97 $\pm$ 2.50	734,913
Southern Dogface ( <i>Zerene cesonia</i> )	11 (2%)	0.06 $\pm$ 0.33	41,947
Lyside Sulphur ( <i>Krigonia lyside</i> )	3 (1%)	0.02 $\pm$ 0.16	12,039
Other Pieridae (Pieridae spp.)	4 (1%)	0.02 $\pm$ 0.18	16,506
<i>Papilionidae</i>	12 (2%)	0.06 $\pm$ 0.30	160,349
Pipevine Swallowtail ( <i>Battus philenor</i> )	11 (2%)	0.10 $\pm$ 0.47	73,539
Black Swallowtail ( <i>Papilio polyxenes</i> )	1 (0%)	0.01 $\pm$ 0.07	3,786
<i>Lycaenidae</i>	1 (0%)	0.001 $\pm$ 0.08	4,467
Small Copper ( <i>Lycaena phlaeas</i> )	1 (0%)	0.001 $\pm$ 0.08	4,467
<i>Hesperiidae (Skippers)</i>	12 (2%)	0.06 $\pm$ 0.33	44,673
Fiery Skipper ( <i>Hylephila phyleus</i> )	12 (2%)	0.06 $\pm$ 0.33	44,673
<i>Sphingidae (Sphinx Moths)</i>	12 (2%)	0.06 $\pm$ 0.33	44,673
<i>Other Heterocera (Moths)</i>	7 (1%)	0.04 $\pm$ 0.20	26,804

<sup>a</sup>See text for ratios used to extrapolate roadkill counts on unsampled side of roadway from sampled side.

<sup>b</sup>Length of highways is 76,096 km from Table 1.

**Table 3. Lepidoptera roadkill spatial correlations ( $r_s$ ) for spring 2021 in monarch migratory Central Funnel and eastwards for 100m transects.<sup>a</sup>**

Species	Monarch	Variegated Fritillary	Painted Lady	Red Admiral	Orange Sulphur
Monarch	1.00	0.18*	0.20*	0.20	0.19*
Variegated Fritillary		1.00	0.30*	0.24*	0.48*
Painted Lady			1.00	0.13*	0.29*
Red Admiral				1.00	0.19*
Orange Sulphur					1.00

<sup>a</sup>Asterisks indicate significant correlation ( $P < 0.05$ ; paired Spearman rank order correlations with Holm's correction for multiple comparisons).

**Table 4. Plant counts and monarch larvae per plant for 5 m x 100 m transects at different distances to the road edge from March-May 2021.<sup>a</sup>**

Variable	Transect Distance to Road Edge (N)	
	$\leq 5$ m	5-10 m
Asclepias Plants <sup>b</sup>	6.43 $\pm$ 21.30a (314)	8.11 $\pm$ 29.00a (314)
Non-Asclepias Plants <sup>b</sup>	110.42 $\pm$ 239.25a (314)	89.40 $\pm$ 141.96a (314)
Monarch Larvae per Milkweed Plant <sup>c</sup>	0.05 $\pm$ 0.25a (81)	0.04 $\pm$ 0.14a (62)

<sup>a</sup>Means in the same row followed by the same letter are not significantly different ( $P < 0.05$ ; omnibus Kruskal-Wallis test followed by Wilcoxon Rank Sum Test for pairwise comparisons with Holm's correction for multiple comparisons).

<sup>b</sup>N= Number of transects

<sup>c</sup>N = Number of transects with at least one milkweed plant



**Table 5. Monarch-preferred nectar plant 100 x 10 m counts for *Asclepias* spp. versus non-*Asclepias* spp. plants by transect type.<sup>a</sup>**

Species Group	Transect Type (n)		
	$\bar{X} \pm SD$ (Percent of Transects with Plants)		
	Dispersed (196)	Random Dispersed (105)	Adventitious (13)
<i>Asclepias</i> spp.	13.35 ± 39.85b (43%)	8.68 ± 26.28b (40%)	79.92 ± 146.50a (85%)
Non- <i>Asclepias</i> spp.	189.97 ± 441.36a (83%)	202.13 ± 314.09a (87%)	329.62 ± 202.13a (100%)

<sup>a</sup>Inner and outer 5 m transects combined. All Texas regions included. Means in the same row followed by the same letter are not significantly different (P < 0.05; omnibus Kruskal-Wallis test followed by Wilcoxon Rank Sum Test for pairwise comparisons with Holm’s correction for multiple comparisons). Multiply figures by 10 to obtain estimated plant mean density per ha. within 10 m Roadway (Mean Plants/0.1 ha). Divide figures by 1,000 to get density per sq. meter.

**Table 6. Milkweed plant 100m x 5m transect counts in spring 2021 monarch migratory Central Funnel and eastwards.<sup>a</sup>**

Species <sup>b</sup>	Plant Counts (Percent of Taxa) (n = 4,567 plants)	Plants per 100m x 5m Transect (Mean ± SD) (n = 314 total transects)	Mean Stems per Plant (Mean ± SD) (n)	Estimated Stems per Species = Plant Count x Mean Stems Per Plant (Percent of Taxa) (n = estimated 20,354 stems)	Mean Length Longest Stems per Plant (cm) (Mean ± SD) (n)
Green antelopehorn ( <i>Asclepias viridis</i> )	2,000 (44%)	6.37 ± 27.15	2.00 ± 1.68 (298)	3,993 (20%)	37.16 ± 14.88 (298)
Antelopehorns ( <i>A. asperula</i> ssp. <i>capricornu</i> )	1,409 (31%)	4.49 ± 22.17	8.30 ± 11.57 (258)	11,698 (57%)	33.88 ± 10.20 (258)
Zizotes Milkweed ( <i>A. oenotheroides</i> )	683 (15%)	2.18 ± 11.34	3.32 ± 3.36 (150)	2,268 (11%)	16.15 ± 6.33 (150)
Slim Milkweed ( <i>A. linearis</i> )	351 (8%)	1.12 ± 19.81	5 (1)	1,755 (9%)	27 (1)
Butterlyweed ( <i>A. tuberosa</i> )	51 (1%)	0.16 ± 1.75	10.44 ± 10.86 (16)	532 (3%)	43.50 ± 11.84 (16)
Green Comet Milkweed ( <i>A. viridiflora</i> )	36 (1%)	0.11 ± 1.15	1.25 ± 0.44 (20)	45 (0.22%)	19.00 ± 7.91 (20)

<sup>a</sup>From data of all 314 transects

<sup>b</sup>Six other less common milkweed species omitted from table (number plants): Engelmann's Milkweed, *A. engelmanniana* (16), Emory's milkweed, *A. emoryi* (15), Clasping milkweed, *A. amplexicaulis*, (2), species similar to Narrowleaf milkweed, near *A. fascicularis* (2), broadleaf milkweed, *A. latifolia* (1), and Whorled milkweed, *A. verticillata* (1).

**Table 7. *Asclepias* spp. number stems per plant, length of longest stem per plant, and monarch larvae per plant by Texas region for March-May 2021.<sup>a</sup>**

Variable/Milkweed Species	Texas Region (n)		
	Central Funnel	Coastal Funnel	Northeast Texas
<i>Number of Stems per Plant</i>			
<i>Asclepias asperula</i> ssp. <i>capricornu</i>	8.77 ± 11.97a (236)	4.00 ± 1.60a (12)	2.30 ± 1.57b (10)
<i>Asclepias viridis</i>	2.21 ± 1.63a (117)	1.63 ± 0.95b (137)	2.57 ± 2.94ab (44)
<i>Asclepias oenotheroides</i>	2.98 ± 2.39a (86)	3.83 ± 4.44a (60)	3.00 ± 1.41a (4)
<i>Length of Longest Stem per Plant</i>			
<i>Asclepias asperula</i> ssp. <i>capricornu</i>	34.07 ± 10.07ab (236)	24.75 ± 6.31c (12)	40.50 ± 10.89a (10)
<i>Asclepias viridis</i>	40.49 ± 14.88b (117)	31.72 ± 13.23c (137)	45.25 ± 13.70a (44)
<i>Asclepias oenotheroides</i>	15.73 ± 5.82a (86)	16.52 ± 7.12a (60)	19.75 ± 2.22a (4)
<i>Number of Monarch Larvae per Plant</i>			
<i>Asclepias asperula</i> ssp. <i>capricornu</i>	0.004 ± 0.065b (236)	0.00 ± 0.00b (12)	0.700 ± 1.252a (10)
<i>Asclepias viridis</i>	0.068 ± 0.486a (117)	0.022 ± 0.147a (137)	0.091 ± 0.291a (44)
<i>Asclepias oenotheroides</i>	0.023 ± 0.152a (86)	0.00 ± 0.00a (60)	0.00 ± 0.00a (4)

<sup>a</sup>Means in the same row followed by the same letter are not significantly different (P < 0.05; omnibus Kruskal-Wallis test followed by Wilcoxon Rank Sum Test for pairwise comparisons with Holm's correction for multiple comparisons).

**Table 8. Monarch-preferred nectar plant 100 x 10 m counts for *Asclepias* spp. versus non-*Asclepias* spp. plants by Texas region for March-May 2021.<sup>a</sup>**

Species Group	Texas Region (n)		
	Central Funnel (161)	Coastal Funnel (97)	Northeast Texas (43)
<i>Asclepias</i> spp.	13.50 ± 38.18a	10.43 ± 33.43b	7.98 ± 31.31c
Non- <i>Asclepias</i> spp.	170.61 ± 215.57a	178.06 ± 289.92a	198.02 ± 231.71a

<sup>a</sup>Inner and outer 5 m transects combined. Adventitious transects were omitted. Means in the same row followed by the same letter are not significantly different (P < 0.05; omnibus Kruskal-Wallis test followed by Wilcoxon Rank Sum Test for pairwise comparisons with Holm’s correction for multiple comparisons).



**Table 9. Monarch-preferred nectar plant 50 m x 5 m dispersed and adventitious transect (n = 209) percent cover for various taxa in March-May 2021 monarch migratory Central Funnel and eastwards.<sup>a</sup>**

Species	Total Percent Cover (Percent of Species)	Percent Cover per 50m x 5m Transect (Mean ± SD) (n = 209 dispersed transects)	Estimated Total Area (Ha.) within 5 m Roadway = (Mean Percent Cover/100) x 79,096 km Length Highways <sup>b</sup>
Seaside Goldenrod ( <i>Solidago semperviens</i> )	79 (15%)	0.38 ± 3.75	301
Texas Vervain ( <i>Verbena halei</i> )	76 (15%)	0.36 ± 2.80	285
Engelmann Daisy ( <i>Engelmannia peristenia</i> )	63 (12%)	0.30 ± 1.17	237
Lance Leaved Coreopsis ( <i>Coreopsis lanceolata</i> )	56 (11%)	0.27 ± 1.81	214
Maltese Star Thistle ( <i>Centaurea melitensis</i> )	40 (8%)	0.19 ± 2.77	150
Lyreleaf Sage ( <i>Salvia lyrata</i> )	34 (7%)	0.16 ± 2.09	127
Lemon Beebalm ( <i>Monarda citriodora</i> )	33 (6%)	0.16 ± 1.18	127
Common Sunflower ( <i>Helianthus annuus</i> )	15 (3%)	0.07 ± 0.43	55
Mealycup Sage ( <i>Salvia farinacea</i> )	15 (3%)	0.07 ± 1.04	55
Slender Vervain ( <i>Verbena rigida</i> )	14 (3%)	0.07 ± 0.71	55
Black Eyed Susan ( <i>Rudbeckia hirta</i> )	11 (2%)	0.05 ± 0.45	40
Green Antelopehorn* ( <i>Asclepias viridis</i> )	10 (2%)	0.05 ± 0.26	--
Climbing Milkweed Vine ( <i>Funastrum cynanchoides</i> )	10 (2%)	0.05 ± 0.69	40
Golden Crownbeard ( <i>Verbesina encelioides</i> )**	10 (2%)	0.05 ± 0.69	40
Prairie Verbena ( <i>Glandularia bipinnatifida</i> )	9 (2%)	0.04 ± 0.23	32
Antelopehorn Milkweed ( <i>Asclepias asperula</i> )	8 (2%)	0.04 ± 0.22	--
Other Verbenas ( <i>Verbena</i> sp.)	8 (2%)	0.04 ± 0.19	32
Zizotes Milkweed ( <i>Asclepias oenotheroides</i> )*	6 (1%)	0.03 ± 0.17	--
American Star Thistle ( <i>Centaurea americana</i> )	5 (1%)	0.02 ± 0.35	16
Spanish Gold ( <i>Grindelia papposa</i> )	4 (1%)	0.02 ± 0.17	16
<b>Total</b>			<b>1,822</b>

<sup>a</sup>Plots are biased towards milkweed from 13 adventitious transects for which visual searches were made over 100 km units. Plants with two bold asterisks (\*\*) are rated "Very High Value" for monarchs, while other plants are "High Value" (USDA NRCS 2018, Pollinator Partnership 2013, Ajilvsgi 2013). Medium value paintbrushes (*Castilleja* spp.) are omitted from this Table.

<sup>b</sup>Length of highways is 76,096 km from Table 1. 76,096 km = [(0.05 km x 0.005km) x 2 x 100 ha/sq km] x (76,096 km Length Highways/0.05 km long transects).

**Table 10. Monarch-preferred nectar plant counts for 100 m x 10 m dispersed and random dispersed transect for various taxa in March-May 2021 within Texas monarch migratory Central Funnel and eastwards.<sup>a</sup>**

<b>Species</b>	<b>Total Plants Counted (Percent of Plants)</b>	<b>Plant Count per 100m x 10m Transect (Mean ± SD) (n = 291 transects)</b>	<b>Estimated Plant Mean Density per Ha. within 10 m Roadway = Mean Plants/0.1 ha</b>	<b>Millions of Plants within 10 m Roadway = (Mean Density per ha.) x (76,096 km Roadway/0.1 km per ha.)<sup>b</sup></b>
Engelmann Daisy ( <i>Engelmannia peristenia</i> )	35.31 ± 106.4	10,276 (17%)	353	269
Lance Leaved Coreopsis ( <i>Coreopsis lanceolata</i> )	29.75 ± 136.36	8,657 (14%)	297	226
Texas Paintbrush ( <i>Castilleja indivisa</i> )**	19.97 ± 63.03	5,812 (10%)	200	152
Texas Vervain ( <i>Verbena halei</i> )	19.49 ± 43.55	5,672 (9%)	195	148
Lemon Beebalm ( <i>Monarda citriodora</i> )	12.56 ± 61.32	3,655 (6%)	126	96
Lyreleaf Sage ( <i>Salvia lyrata</i> )	11.99 ± 160.24	3,489 (6%)	120	91
Common Sunflower ( <i>Helianthus annuus</i> )	11.8 ± 58.01	3,435 (6%)	118	90
Slender Vervain ( <i>Verbena rigida</i> )	10.77 ± 61.41	3,134 (5%)	108	82
Prairie Verbena ( <i>Glandularia bipinnatifida</i> )	8.62 ± 39.86	2,509 (4%)	86	65
Black Eyed Susan ( <i>Rudbeckia hirta</i> )	8.32 ± 49.29	2,422 (4%)	83	63
Green Antelopehorn Milkweed* ( <i>Asclepias viridis</i> )	6.05 ± 26.77	1,761 (3%)	61	46
Maltese Star-Thistle ( <i>Centaurea melitensis</i> )	5.5 ± 93.79	1,600 (3%)	55	42
Climbing Milkweed Vine ( <i>Funastrum cynanchoides</i> )	5.34 ± 38.15	1,555 (3%)	53	40
Downy Paintbrush ( <i>Castilleja sessiflora</i> )	4.39 ± 26.63	1,278 (2%)	44	33
Antelopehorn Milkweed ( <i>Asclepias asperula</i> )*	3.67 ± 17.78	1,069 (2%)	37	28
Other Verbenas ( <i>Verbena sp.</i> )	3.55 ± 15.03	1,032 (2%)	35	27
Zizotes Milkweed ( <i>Asclepias oenotheroides</i> )*	1.97 ± 11.35	572 (1%)	20	15
Brazilian Vervain ( <i>Verbena brasiliensis</i> )	1.95 ± 18.62	566 (1%)	19	14

**Table 10. Monarch-preferred nectar plant counts for 100 m x 10 m dispersed and random dispersed transect for various taxa in March-May 2021 within Texas monarch migratory Central Funnel and eastwards.<sup>a</sup>**

Species	Total Plants Counted (Percent of Plants)	Plant Count per 100m x 10m Transect (Mean ± SD) (n = 291 transects)	Estimated Plant Mean Density per Ha. within 10 m Roadway = Mean Plants/0.1 ha	Millions of Plants within 10 m Roadway = (Mean Density per ha.) x (76,096 km Roadway/0.1 km per ha.) <sup>b</sup>
Rosinweed ( <i>Silphium integrifolium</i> )	1.66 ± 20.17	482 (1%)	17	13
Golden Crownbeard ( <i>Verbesina encelioides</i> )*	1.4 ± 12.25	407 (1%)	14	11
American Star Thistle ( <i>Centaurea americana</i> )	1.1 ± 18.76	320 (1%)	11	8
Total			2,090	1,589

<sup>a</sup>Includes data from 291 dispersed and random-dispersed transects, omitting 13 adventitious transects biased towards milkweeds and transects for OSM road class 5 (FM roads; see Table 1). \* = "Very High Value" and \*\* = "Medium" value for monarchs, while other plants are "High Value" (USDA NRCS 2018, Pollinator Partnership 2013, Ajilvsgi 2013). Nine plant species under 1% counted were omitted from Table.

<sup>b</sup>Length of highways is 76,096 km from Table 1.

**Table 11. Monarch larvae per milkweed plant per roadside transect.<sup>a</sup>**

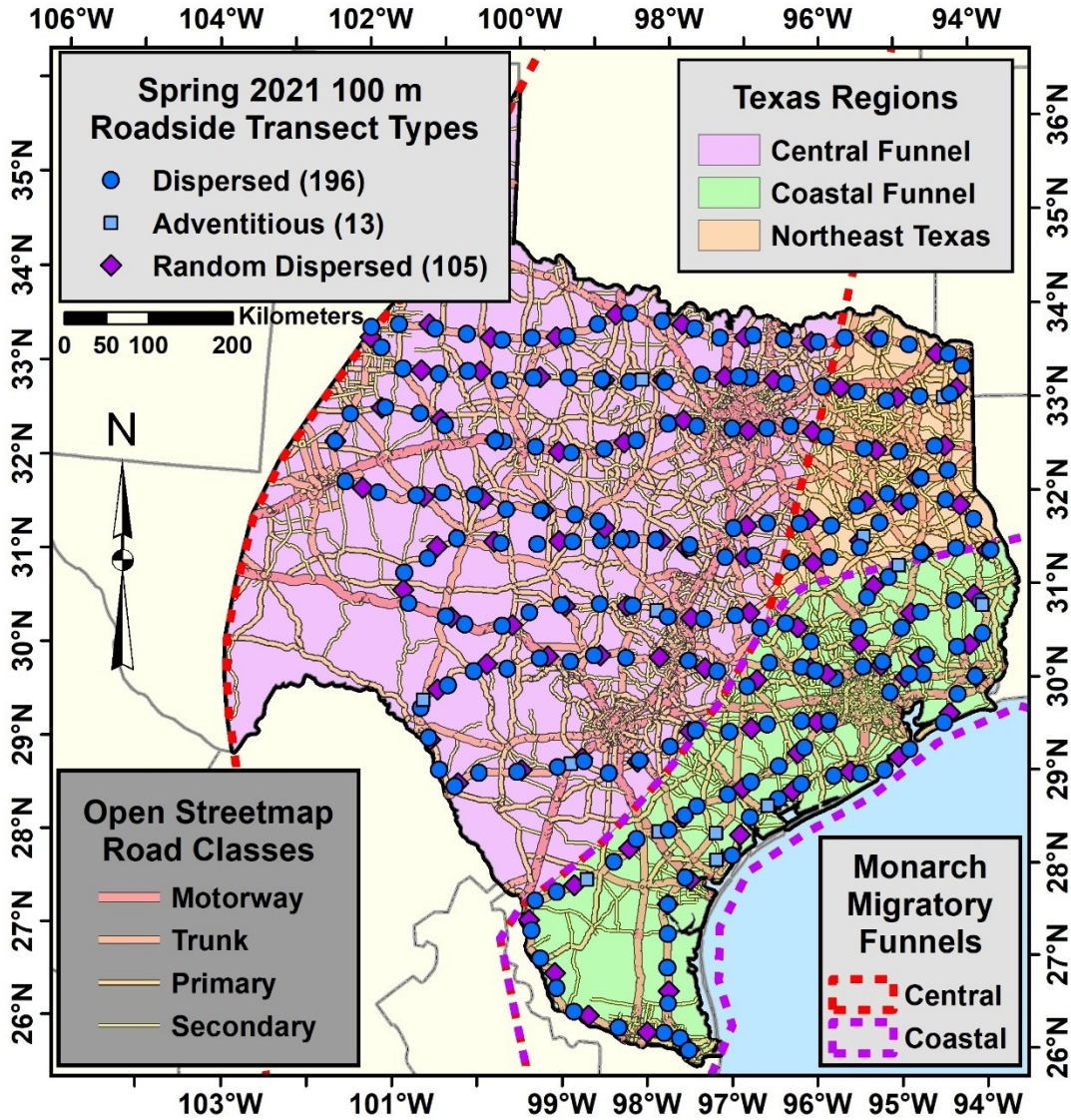
Statistic	Green Antelopehorn	Antelopehorns	Zizotes Milkweed	Green Comet Milkweed
Total Larvae	15	8	2	1
Mean Larvae per Plant ± SD (n)	0.06 ± 0.2a	0.02 ± 0.11a	0.03 ± 0.17a	0.17 ± 0.41
[Range] <sup>b</sup>	(39) [0 - 1]	(38) [0 - 0.7]	(37) [0 - 1]	(6) [0 - 1]

<sup>a</sup>Data from all transects with milkweeds. Up to six milkweed plants per species were examined for larvae in each 100m x 5m roadside transect. Means in the same row with the same letter are not significantly different (P < 0.05; Kruskal-Wallis Test; green comet milkweed omitted from analysis). Four percent of 196 dispersed transects (8) had monarch larvae and 21% of 13 adventitious transects (3) had monarch larvae.

<sup>b</sup>n = number of transects with milkweeds.



## Figures



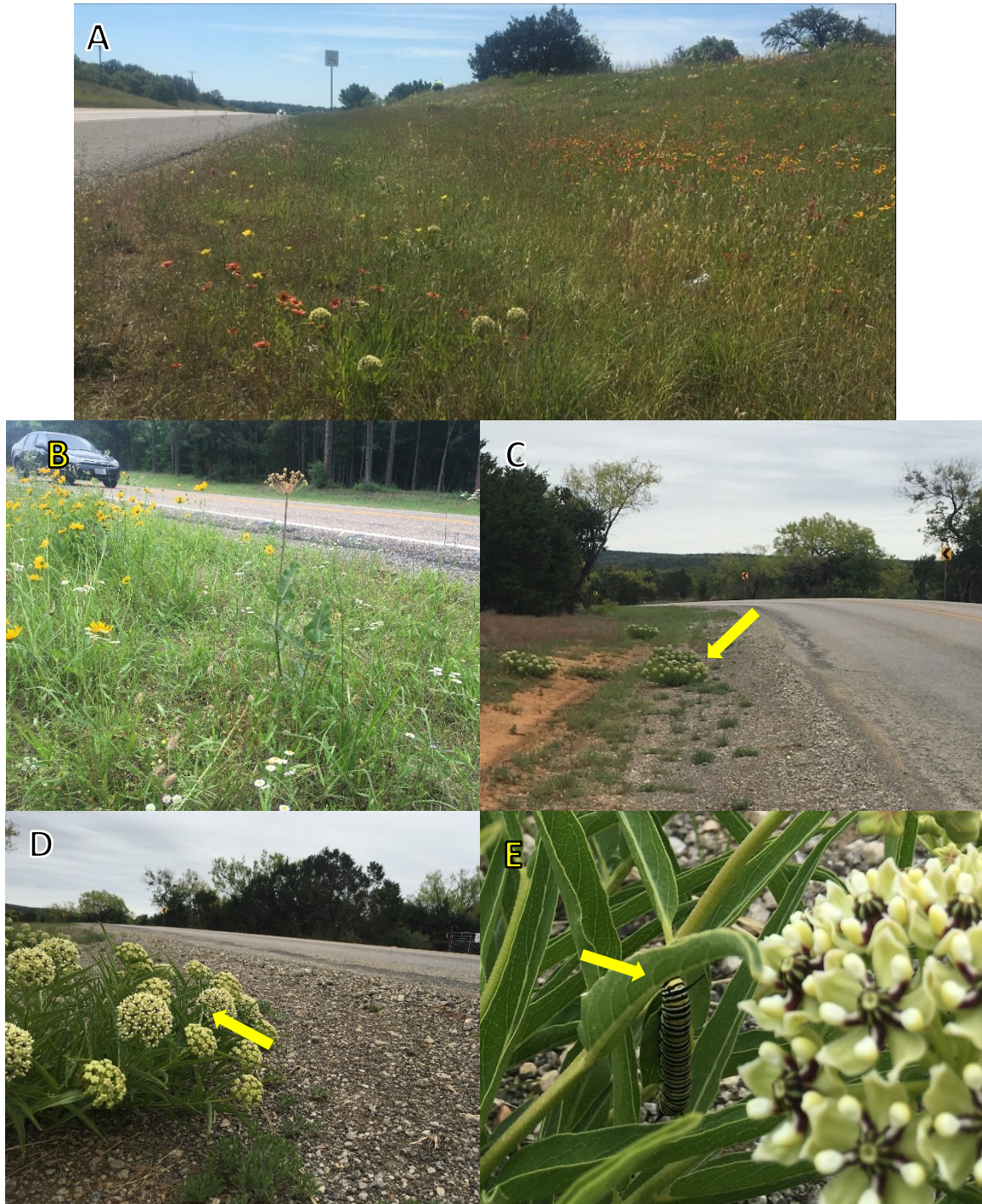
**Figure 1. Distribution of spring 2021 100m x 1m roadkill transects over Texas roadways within the monarch migratory Central Funnel and eastwards.**





**Figure 2. (A-B) Female remigrant monarch ovipositing on stem of green antelopehorn and resulting monarch egg along US-59 northeast of El Campo, TX (1AT40; 3/26/2021); (C) monarch remigrant nectaring on Indian paintbrush along TX-257 on Galveston Island (1AT7; 3/23/21); (D-E) Antelopehorns along US-59 west of Beeville with second instar monarch larva (1AT34; 3/25/21); (F-G) roadkill monarch along US-84 east of Star, TX (3AT21; 4/21/2021).**





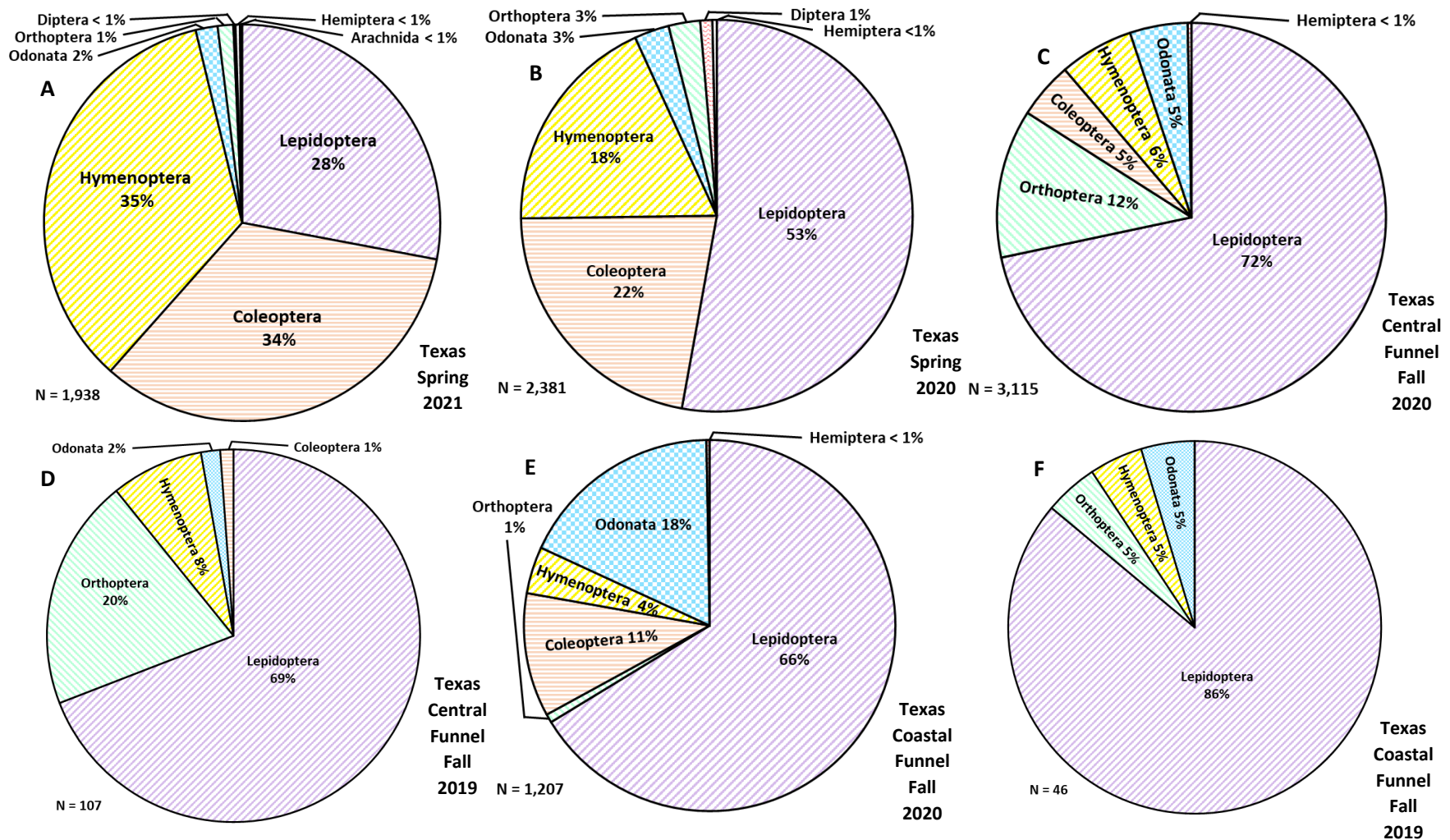
**Figure 3. (A) Antelopehorns roadside hotspot with Engelmann daisy along US-183 south of Zephyr, TX (4AT37; 5/7/2021; no monarch larvae found); (B) clasp milkweed (*Asclepias amplexicaulis*) with lanceleaf coreopsis along TX-11 west of Linden (5AT7; 5/18/2021); (C-E) Antelopehorns on shoulder of FM-574 with fifth instar monarch larva west of Goldwaithe (3AT22; 4/21/21).**



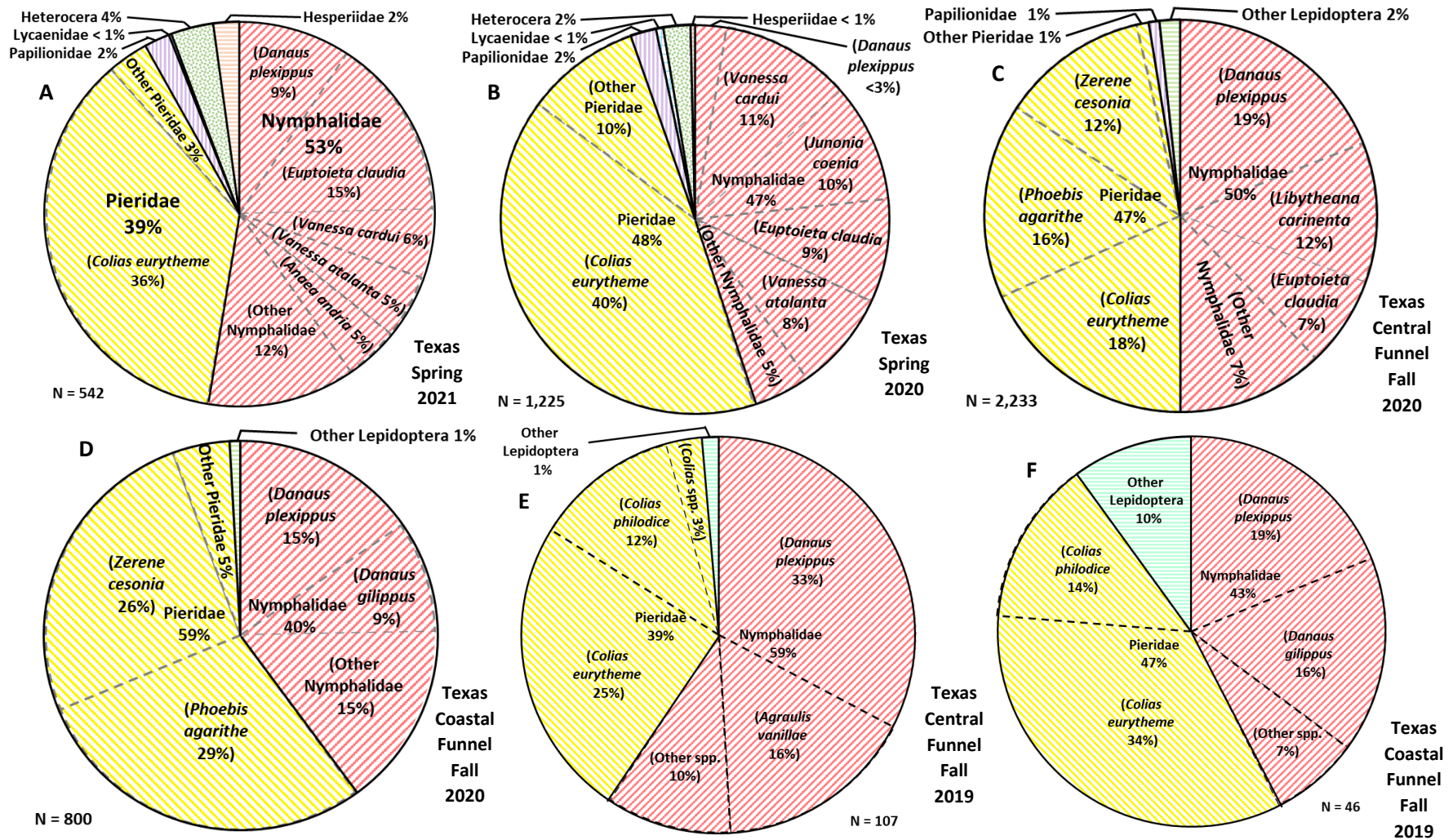


**Figure 4. (A-B) Fifth instar monarch larva on zizotes milkweed close to shoulder of US-277 (2AT15; 4/13/2021); (C-D) fifth instar monarch larva on (C) green antelopehorn and (D) slim milkweed (*Asclepias linearis*) along FM-136 west of Bayside (ACP AD1; 4/9/2021).**





**Figure 5. Percentage roadkill among roadside transects for arthropods: (A-B) Central Funnel and Eastwards in Texas, (A) Mar-May 2021 (Table 2), (B) Apr-May 2020 (Tracy et al. 2021), (C-D) Texas Central Funnel, (C) Sep-Dec 2020 (Tracy et al. 2021), (D) Sep-Dec 2019 (Tracy et al. 2020a); (E-F) Texas Coastal Funnel, (E) Oct-Nov 2020 (Tracy et al. 2021), (F) Oct-Nov 2019 (Tracy et al. 2020a).**

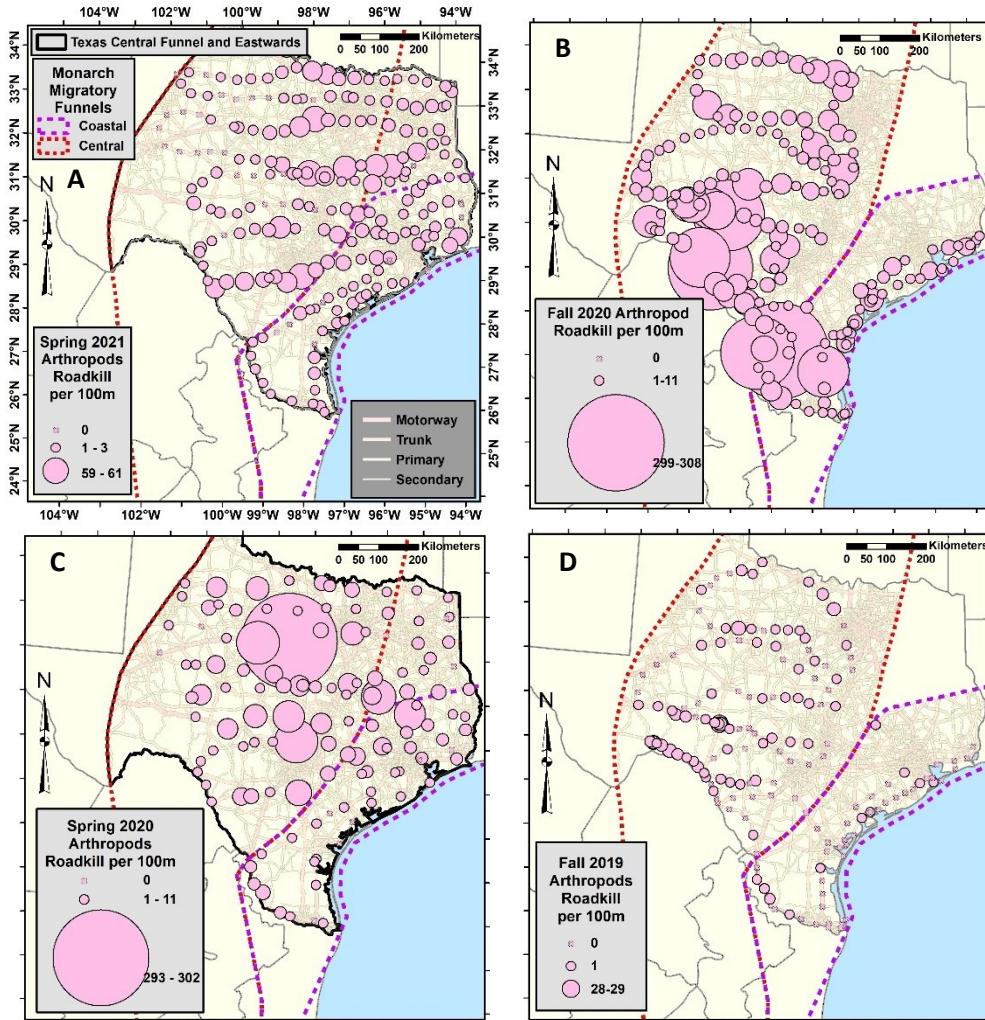


**Figure 6. Percentage roadkill among roadside transects for Lepidoptera taxa: (A-B) Central Funnel and Eastwards in Texas, (A) Mar-May 2021 (Table 2), (B) Apr-May 2020 (Tracy et al. 2021), (C-D) Texas Fall 2020, (C) Central Funnel, Sep-Dec 2020, (D) Coastal Funnel, Oct-Nov 2020 (Tracy et al. 2021); and (E-F) Texas Fall 2010, (E) Central Funnel, Sep-Dec 2019, (F) Coastal Funnel, Oct-Nov 2019 (Tracy et al. 2020a).**



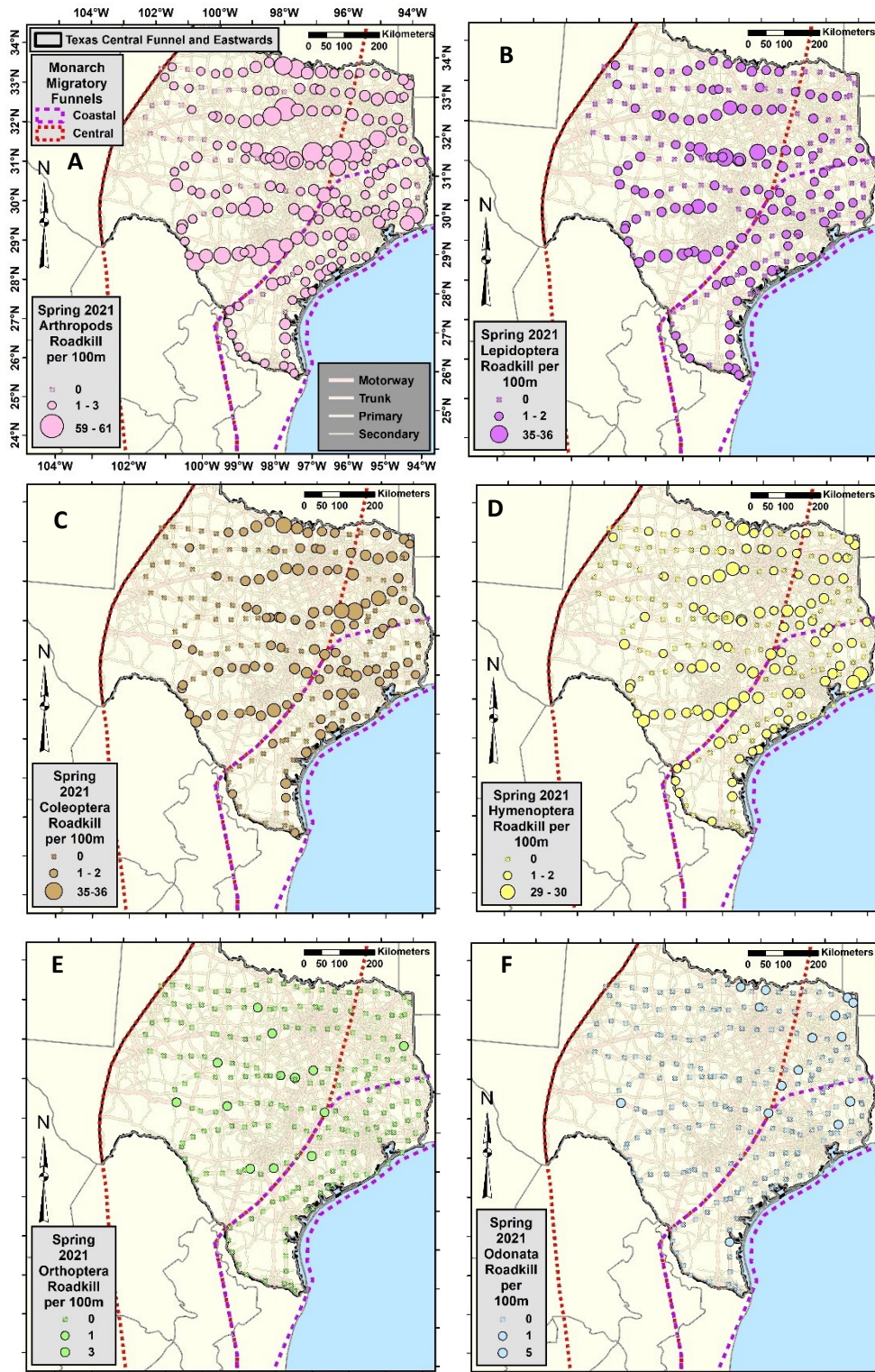


**Figure 7. Most common butterfly species in spring 2021 Texas roadkill: (A) orange sulphur, *Colias eurytheme*; (B) variegated fritillary, *Euptoieta claudia*; (C) monarch, *Danaus plexippus*; (D) painted lady, *Vanessa cardui*; (E) red admiral, *Vanessa atalanta*; (F) goatweed butterfly, *Anaea andria*; (G) hackberry emperor, *Asterocampa celtis*; and (H) question mark, *Polygonia interrogationis* (images, iNaturalist 2021 and BugGuide.Net 2020).**

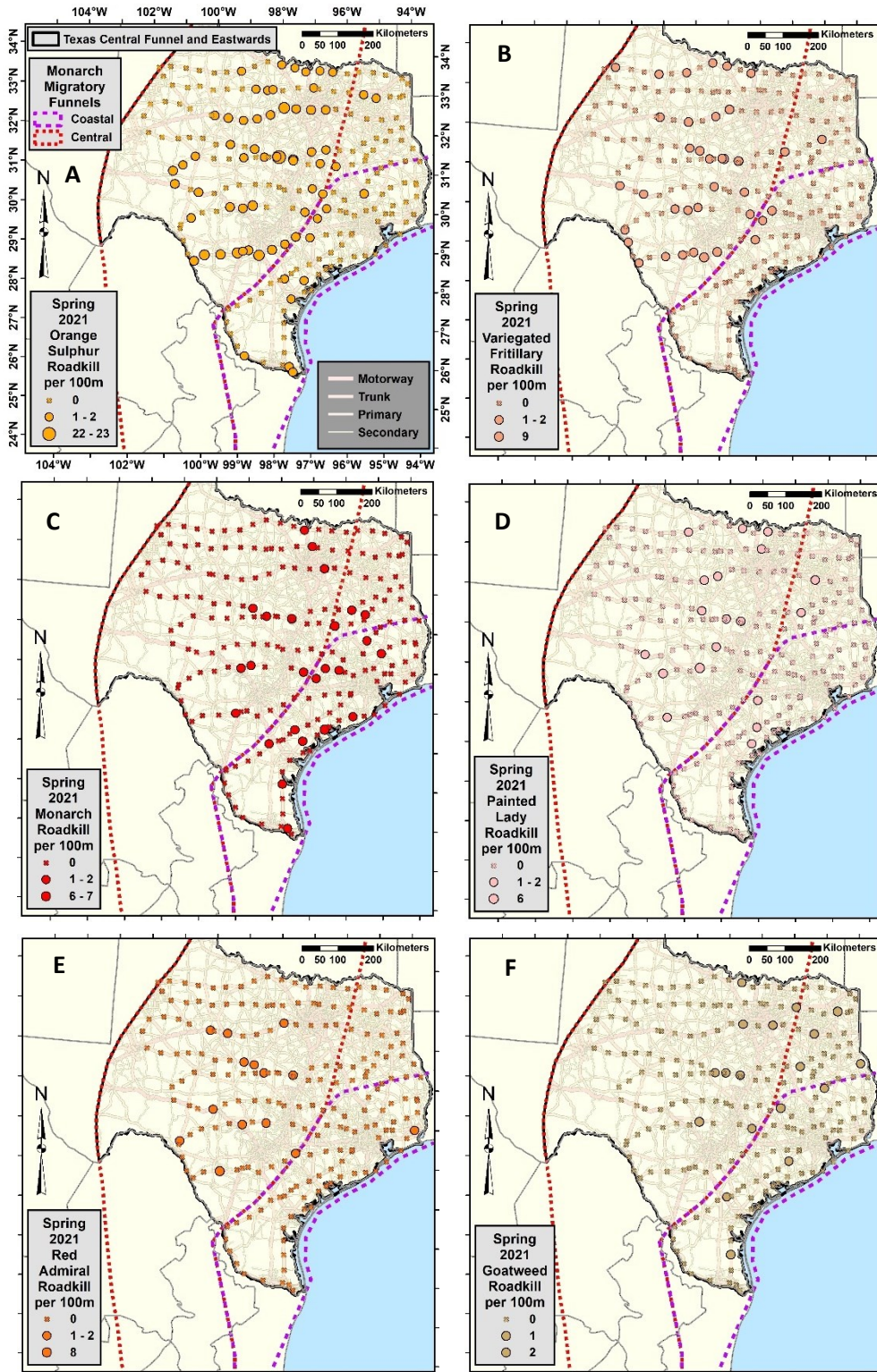


**Figure 8. Distribution of roadkill per 100m x 1m transect (unthinned) for arthropod taxa in Texas monarch migratory (A) spring 2021 Central Funnel and eastwards; (B) fall 2020 Central and Coastal funnels; (C) spring 2020 Central Funnel and eastwards; and (D) fall 2019 Central and Coastal funnels. (symbols ca. proportional among dates).**



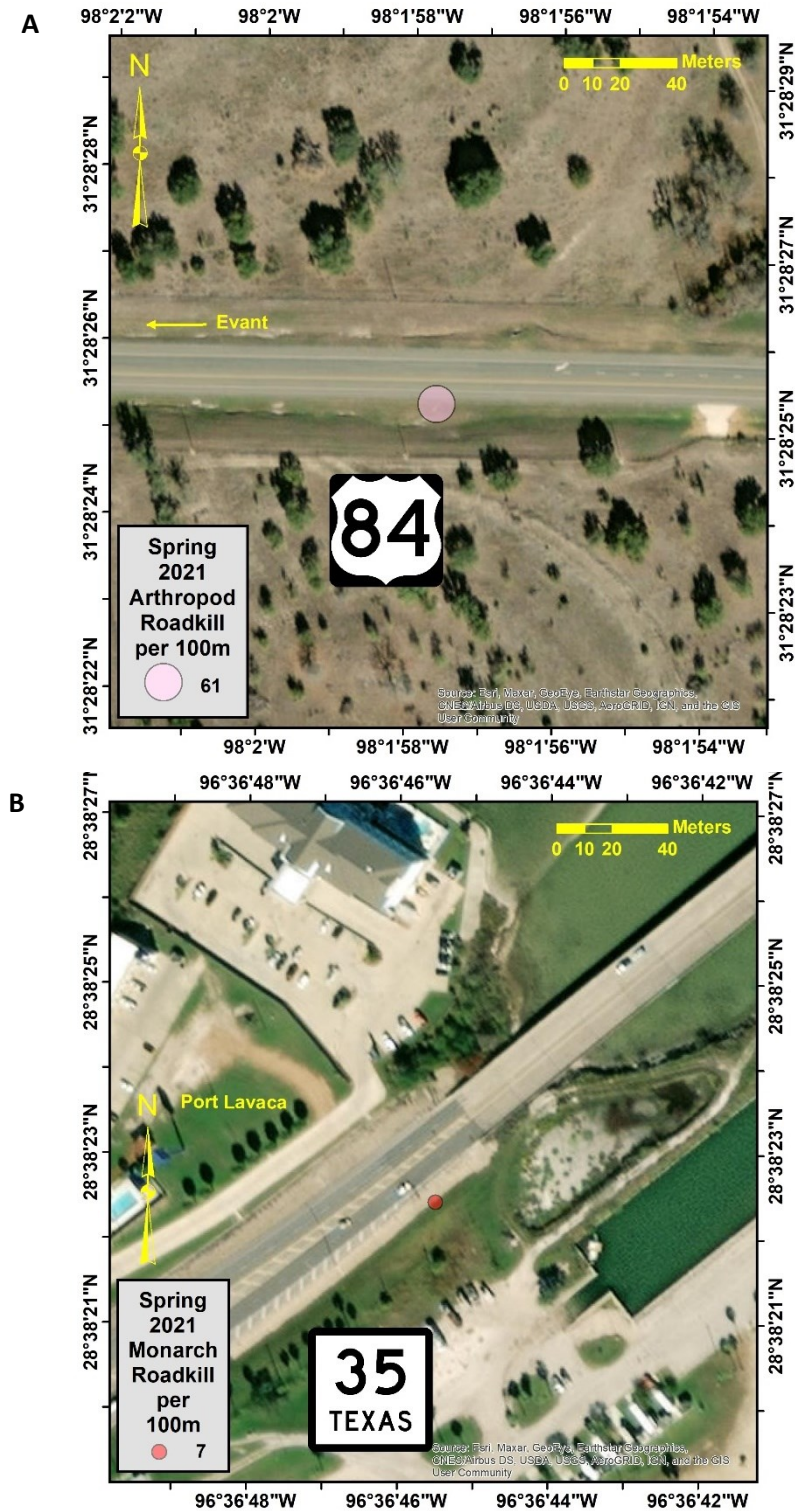


**Figure 9. Distribution of spring 2021 roadkill per 100m x 1m transect (unthinned) for various arthropod taxa in Texas monarch migratory Central Funnel and eastwards: (A) Arthropods; (B) Lepidoptera; (C) Coleoptera; (D) Hymenoptera; (E) Orthoptera; and (F) Odonata (symbols ca. proportional among taxa).**

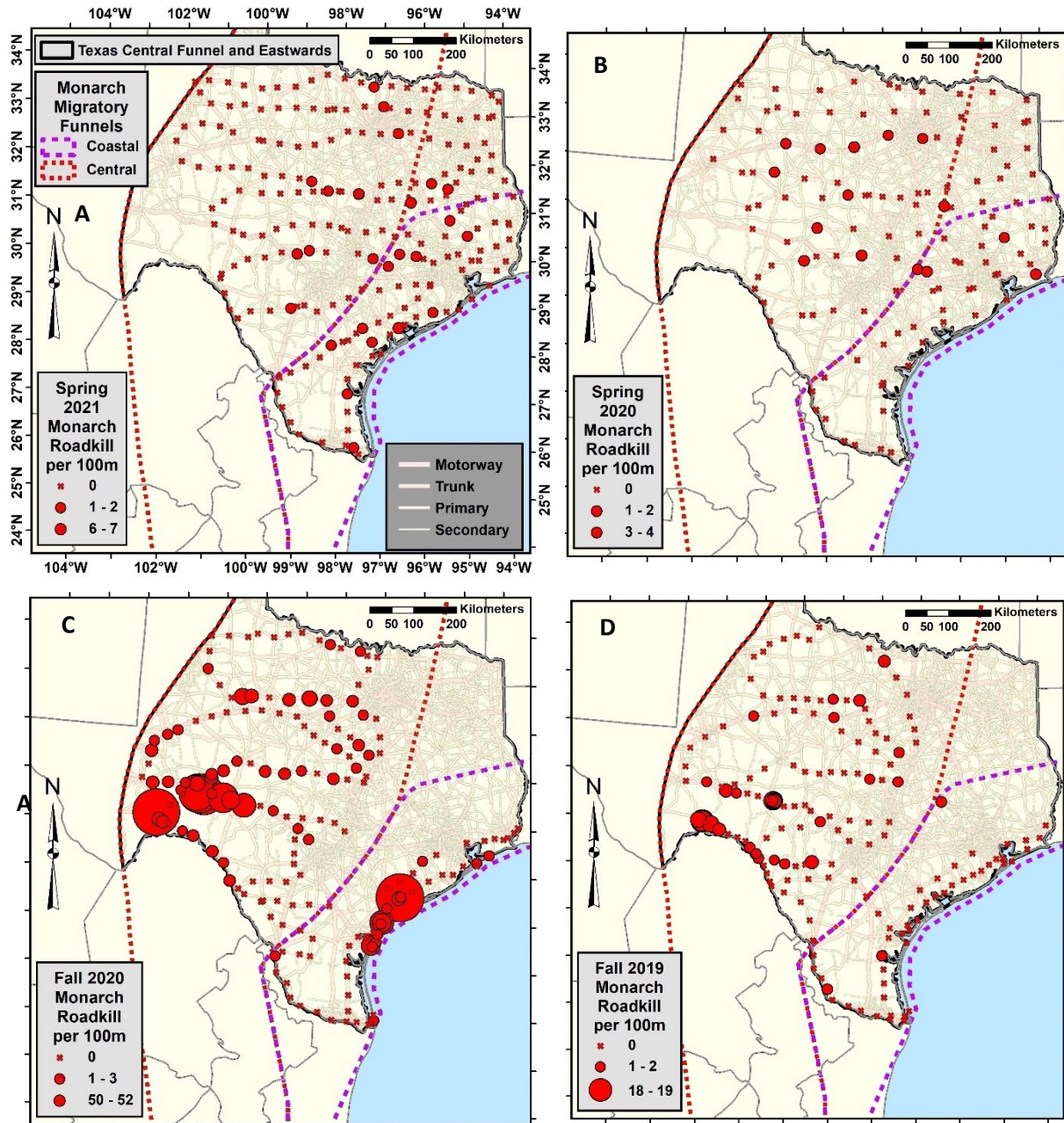


**Figure 10. Distribution of spring 2020 roadkill per 100m x 1m transect (unthinned) for Lepidoptera taxa in Texas monarch migratory Central Funnel and eastwards: (A) Orange Sulphur; (B) Monarch; (C) Variegated Fritillary; (D) Painted Lady; (E) Red Admiral; (F) Goatweed Butterfly (symbols ca. proportional among taxa).**



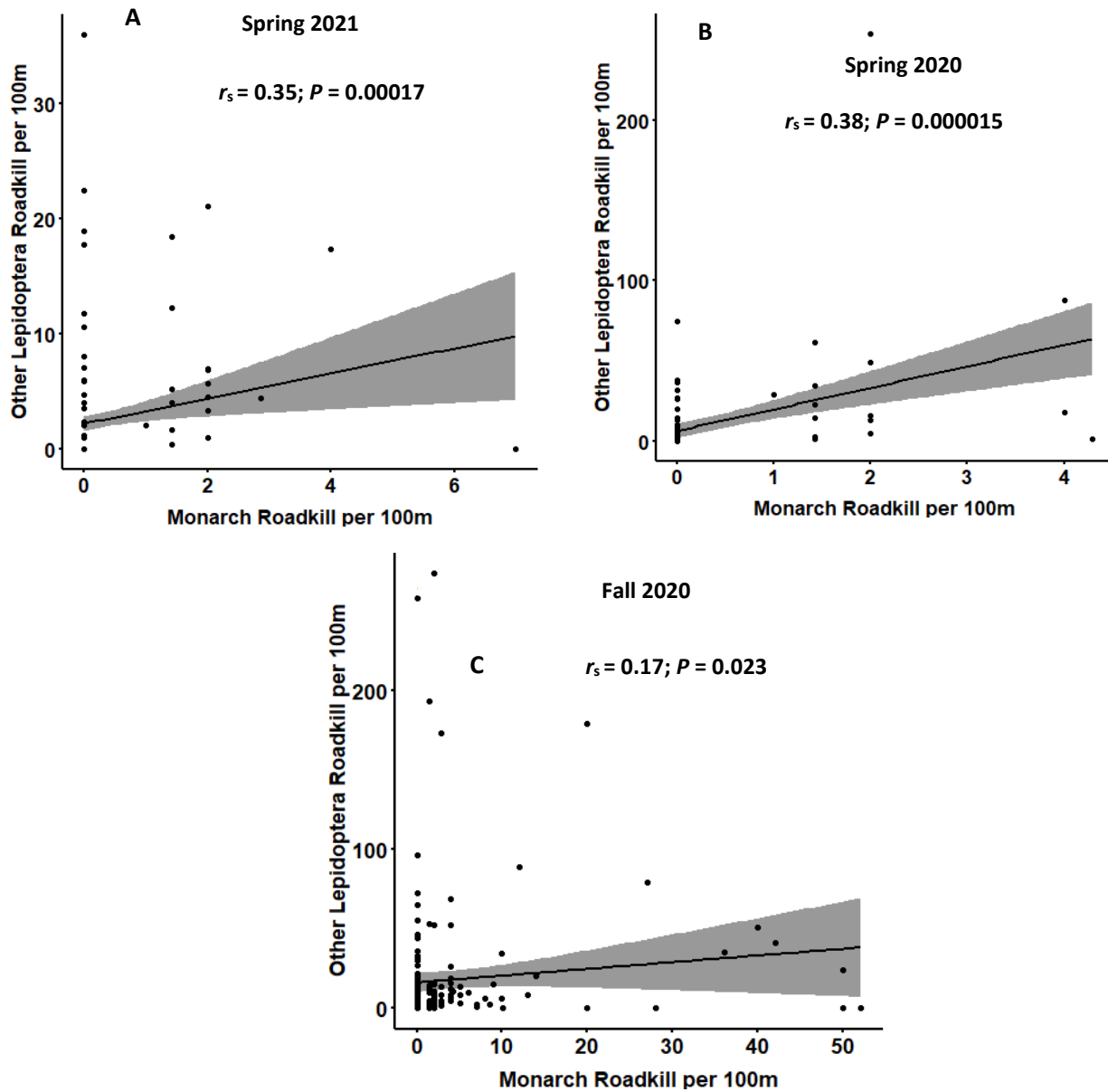


**Figure 11. Roadkill hotspot zones for (A) arthropods 11 km east of Evant along US-84 on 7 May, 2021; and (B) monarchs at Port Lavaca near causeway on TX-35 23 March, 2021.**



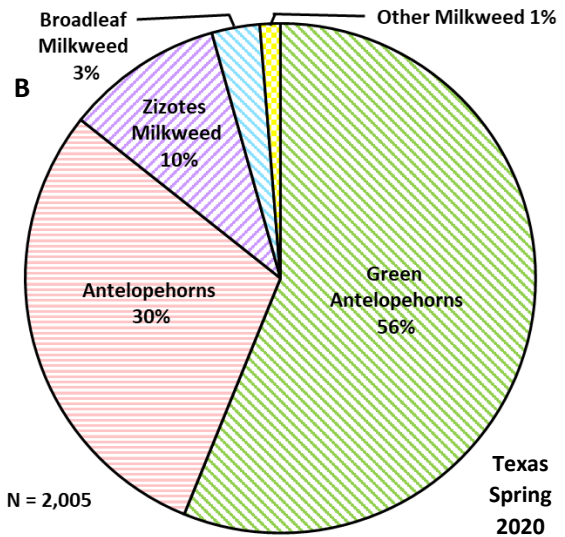
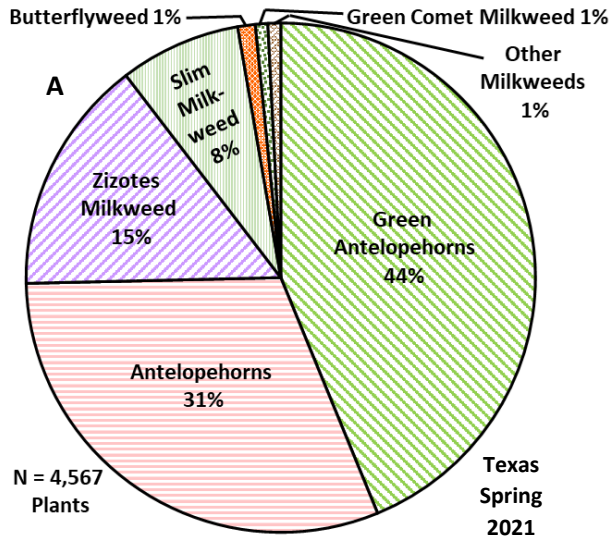
**Figure 12. Distribution of monarch roadkill per 100m x 1m transect (unthinned) in Texas for: (A) spring 2021; (B) spring 2020 (Tracy et al. 2020c); (C) fall 2020 (Tracy et al. 2021); (D) fall 2019 (Tracy et al. 2020b) (symbols ca. proportional among taxa).**



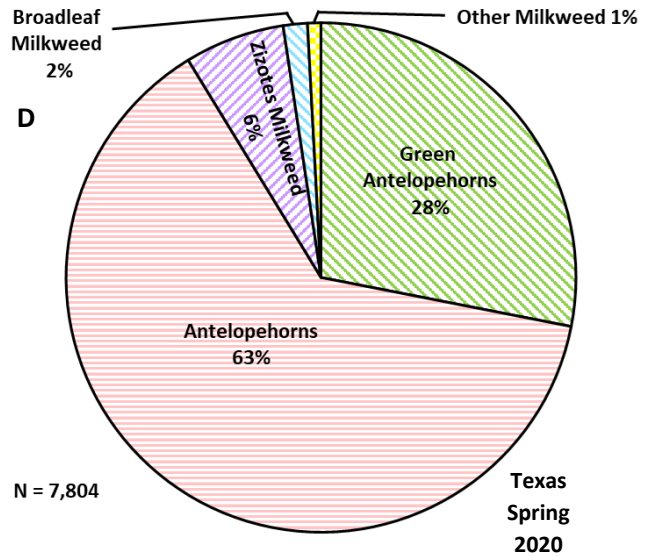
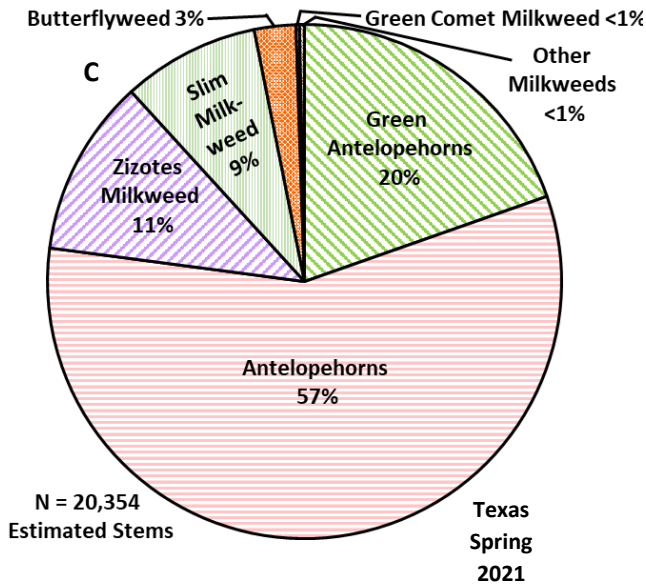


**Figure 13. Spearman’s rank order correlation ( $r_s$ ) between monarch roadkill per 100m x 5m roadside transect and other Lepidoptera roadkill per transect for (A) spring 2021; (B) spring 2020; and (C) fall 2020.**

**Milkweed Plants**

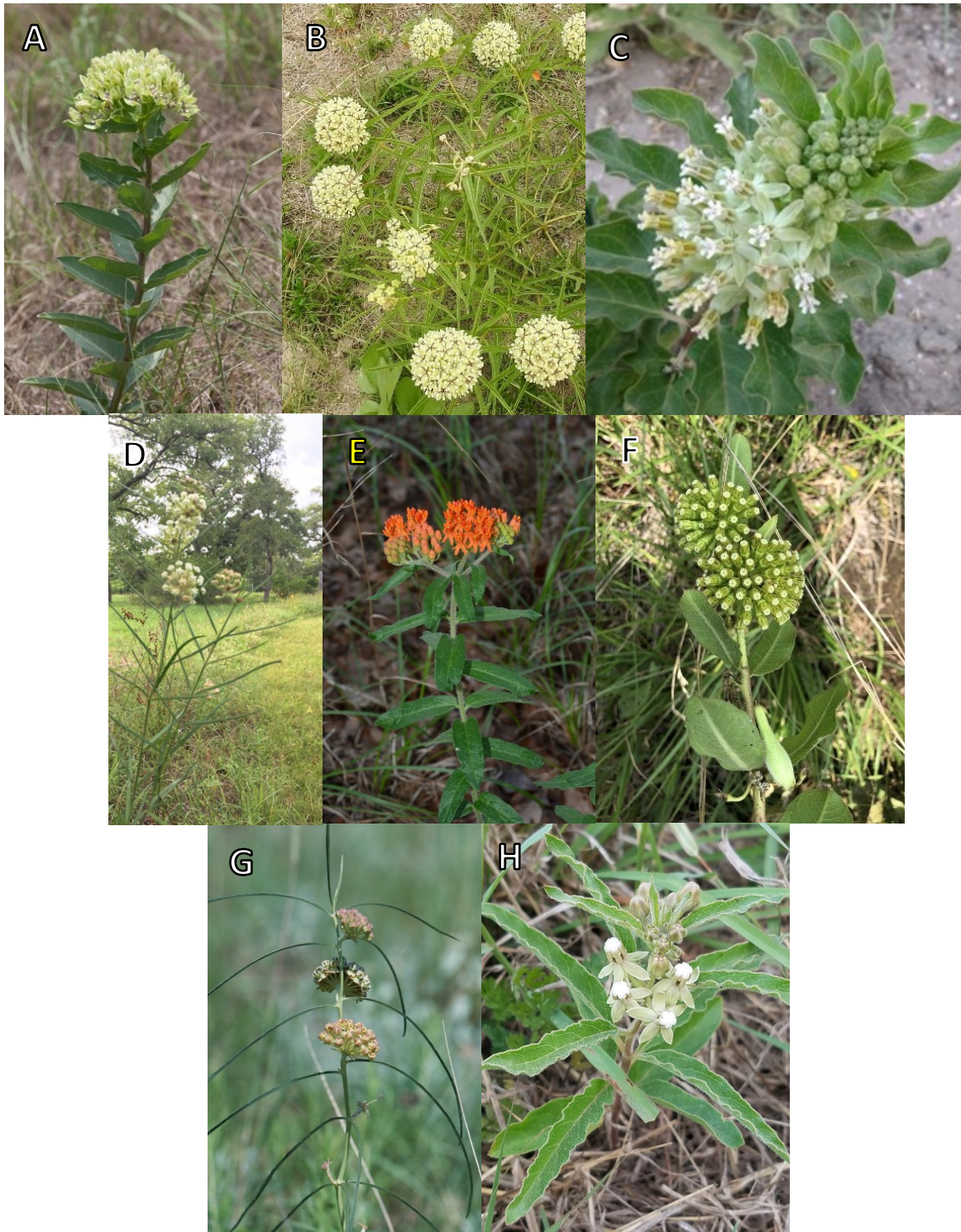


**Milkweed Stems**



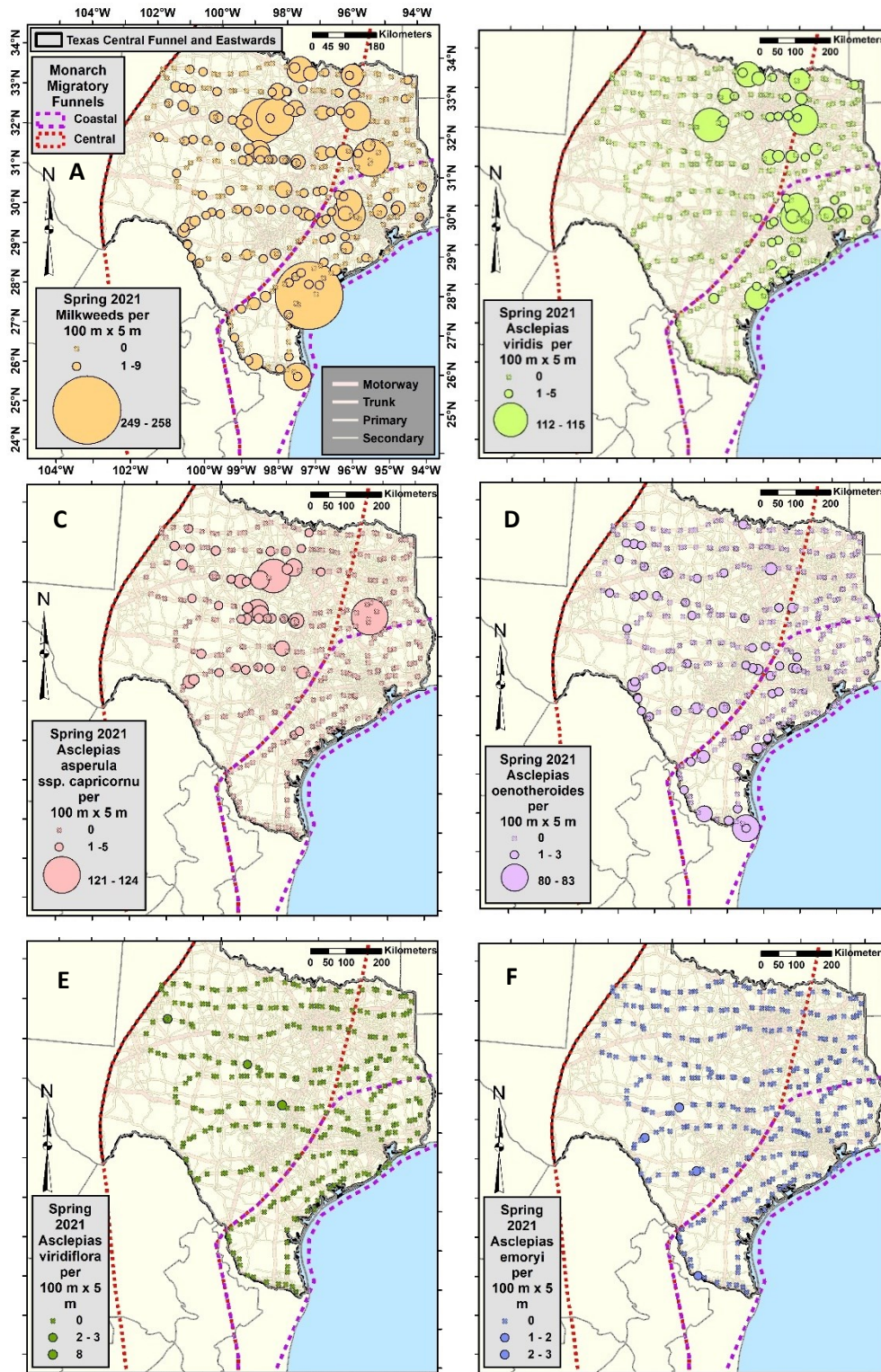
**Figure 14. Percentage (A-B) milkweed plants and (C-D) estimated milkweed stems along roadside transects for Central Funnel and Eastwards in Texas, for Spring 2021 (A,C) and Spring 2020 (B,D) (Tracy et al. 2020c) (see Table 8 for 2021 data and species of other milkweeds).**





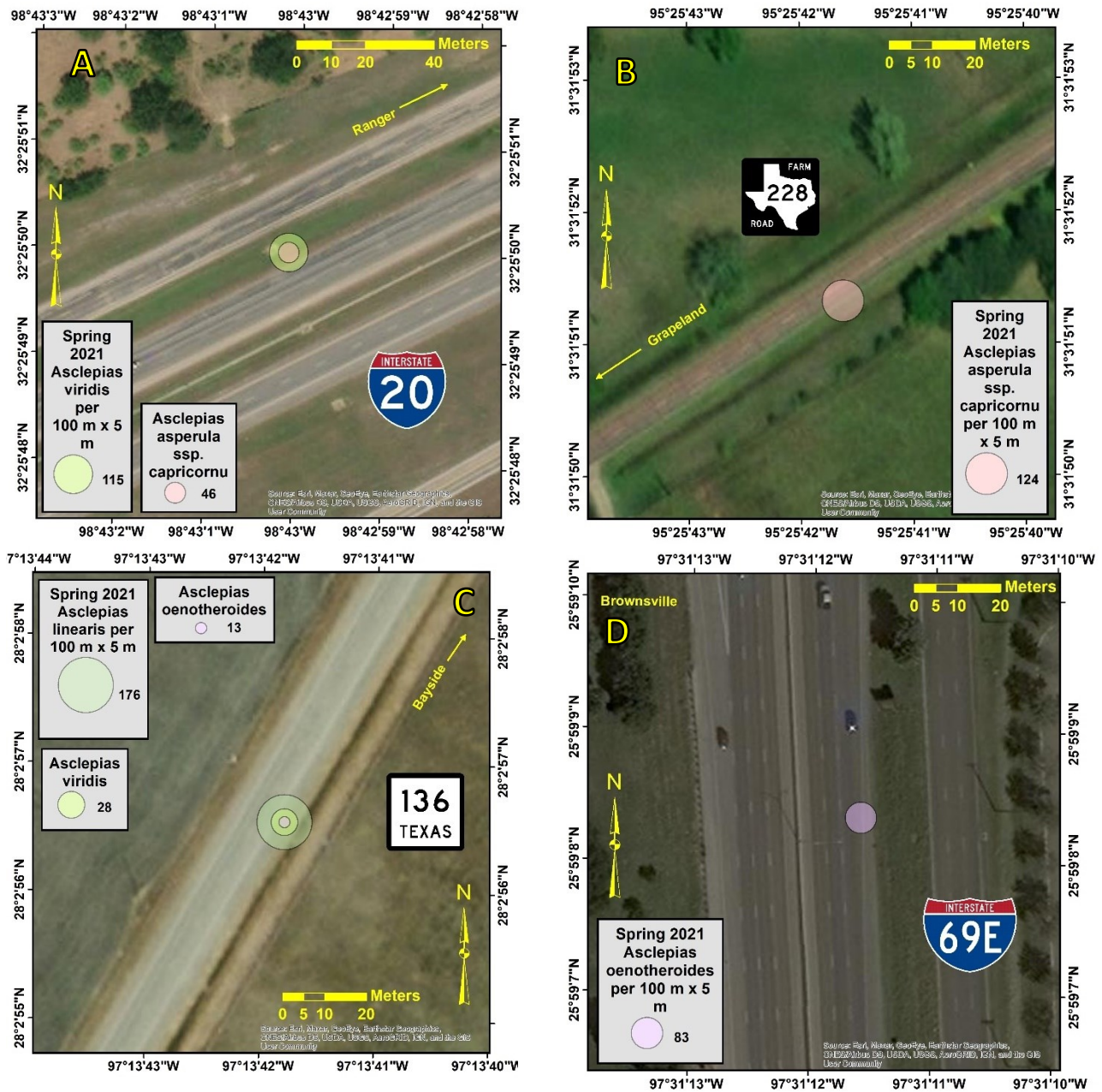
**Figure 15. The most frequent milkweed species (in order) appearing in spring 2021 Texas roadside transects: (A) Green antelopehorns, *Asclepias viridis*; (B) Antelopehorn, *A. asperula* ssp. *capricornu*; (C) zizotes milkweed, *A. oenotheroides*; (D) Slim milkweed, *A. linearis*; (E) Butterflyweed, *A. tuberosa*; (F) Green comet milkweed, *A. viridiflora*; (G) Engelmann's milkweed, *A. engelmanniana*; and (H) Emory's milkweed, *Asclepias emoryi* (images, iNaturalist 2021).**



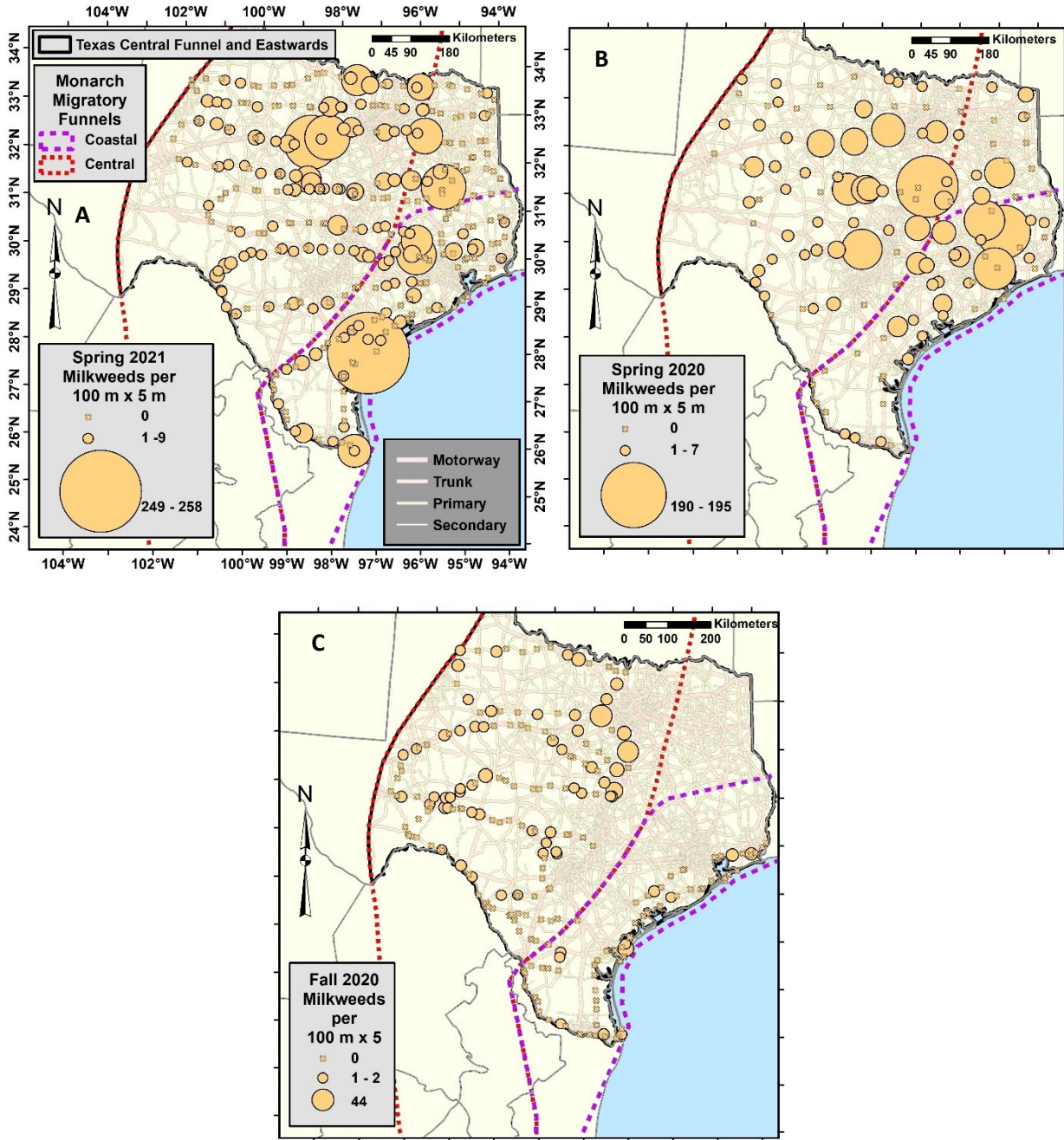


**Figure 16. Distribution of Spring 2021 counts for milkweed plants averaged over all 314 inner and outer 100m x 5m transects (unthinned) in Texas monarch migratory Central Funnel and eastwards: (A) All milkweeds; (B) Green antelopehorn; (C) Antelopehorns; (D) Zizotes milkweed; (E) Green Comet milkweed; and (F) Emory’s milkweeds (symbols ca. proportional among taxa).**

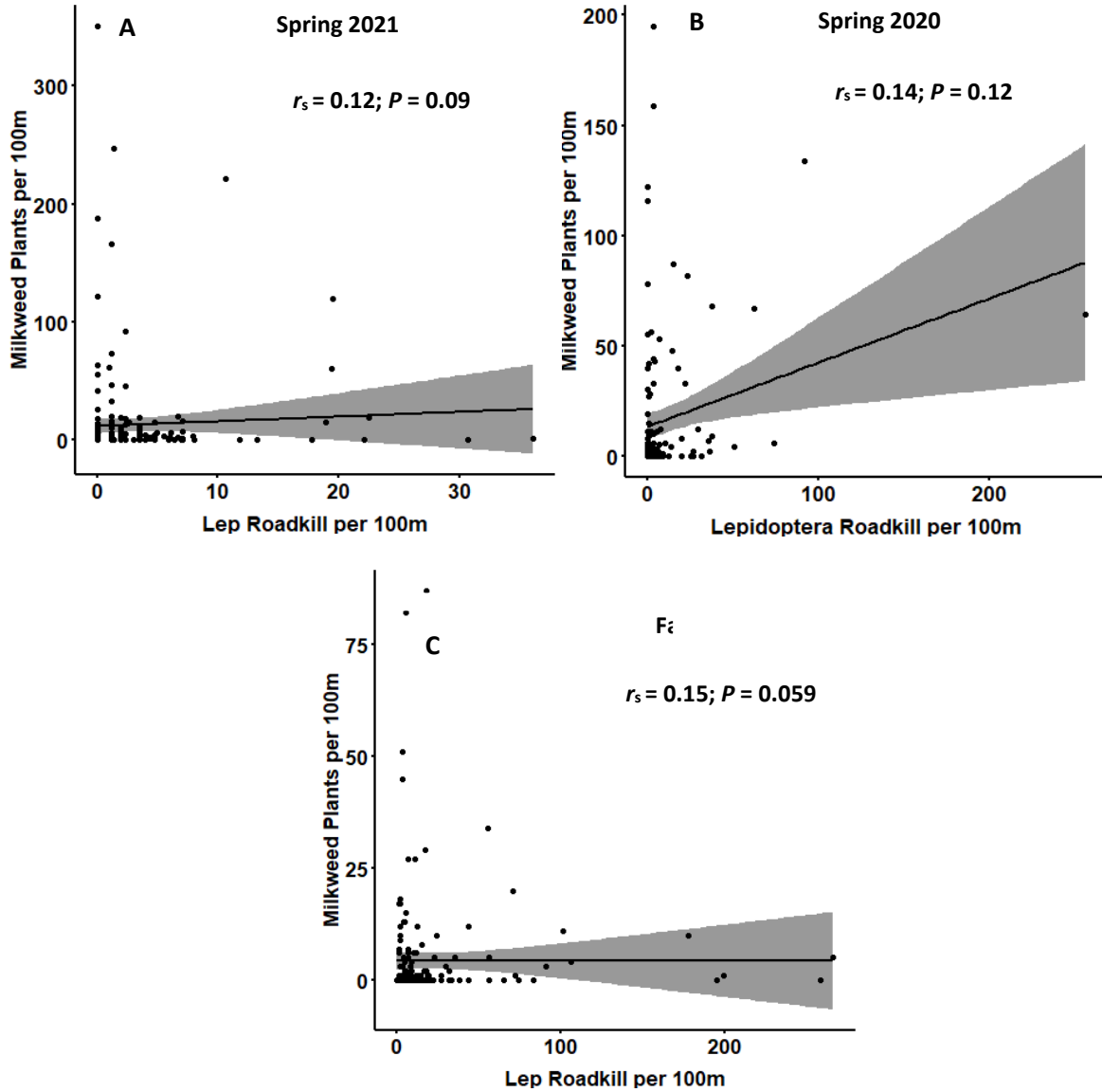




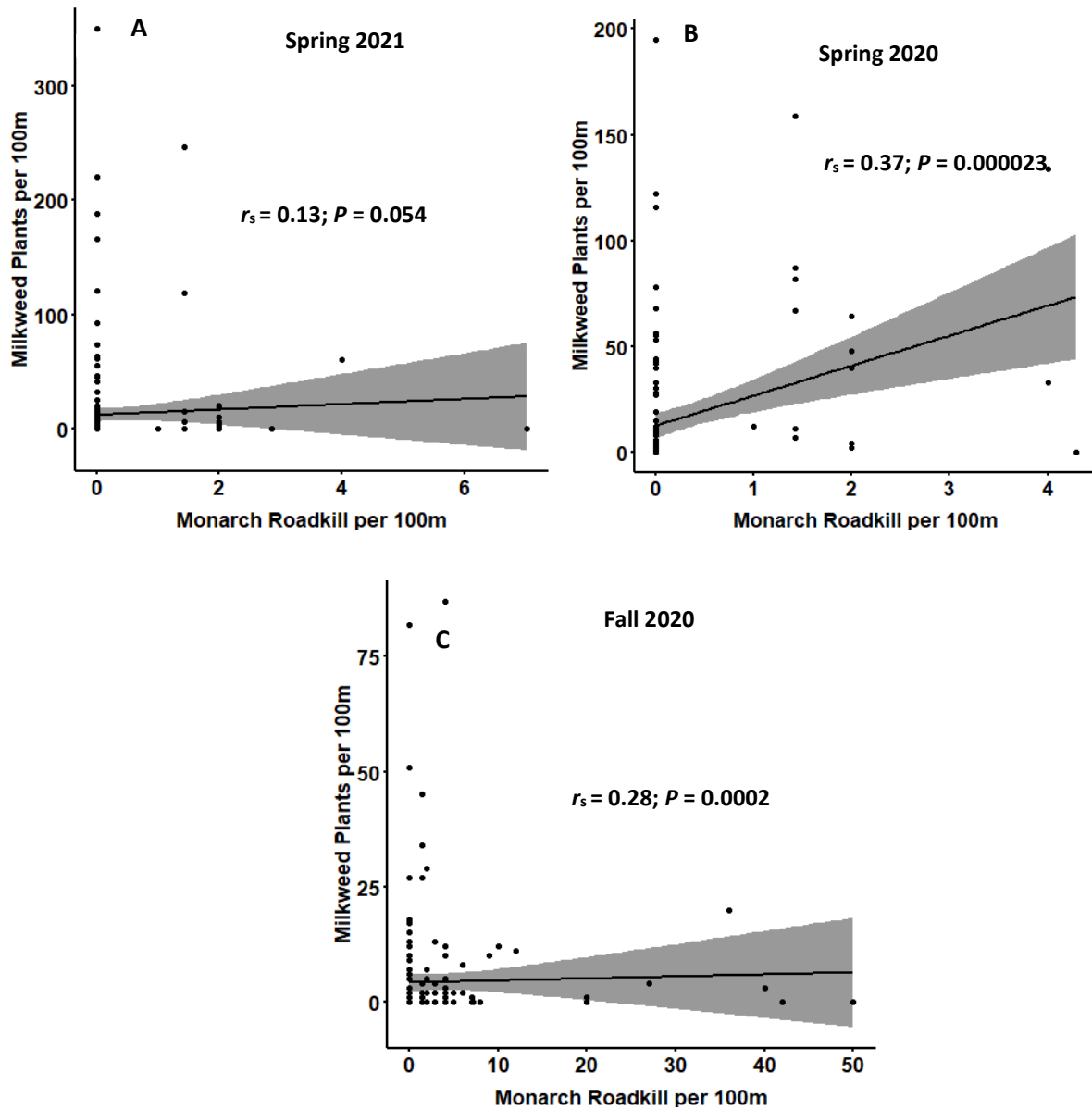
**Figure 17. Milkweed roadside hotspots for (A) Green antelopehorn and antelopehorns, 1.8 km west of Ranger along IH-20 on 5 May, 2021 (dispersed transect); (B) Antelopehorns, 5.25 km east of Grapeland along FM-228 on 20 April, 2021 (adventitious transect); (C) Slim milkweed, green antelophorns, and zizotes milkweed, 5 km southwest of Bayside along TX-136 on 9 April 2021 (adventitious transect); and (D) Zizotes milkweed in Brownsville along IH-69E on 24 March 2021 (dispersed transect).**



**Figure 18. Distribution of milkweed plants (unthinned) per transect in Texas: (A) spring 2021; (B) spring 2020 (Tracy et al. 2020c); (C) fall 2020 (Tracy et al. 2021) (symbols ca. proportional among taxa).**

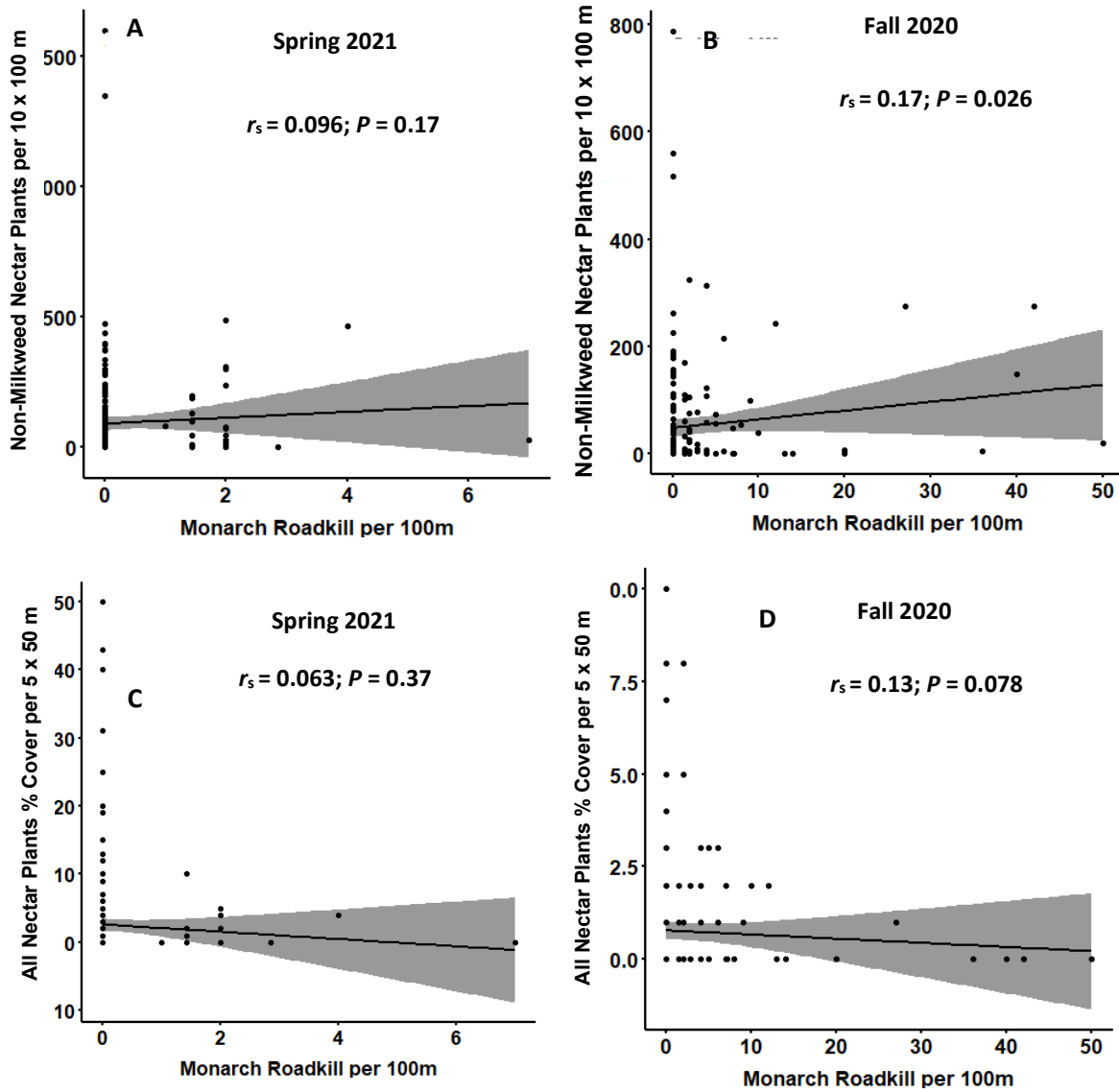


**Figure 19. Spearman’s rank order correlation ( $r_s$ ) between all Lepidoptera roadkill per 100m x 5 m roadside transect and milkweed plants per 100m x 10 m transect for (A) spring 2021; (B) spring 2020; and (C) fall 2020.**

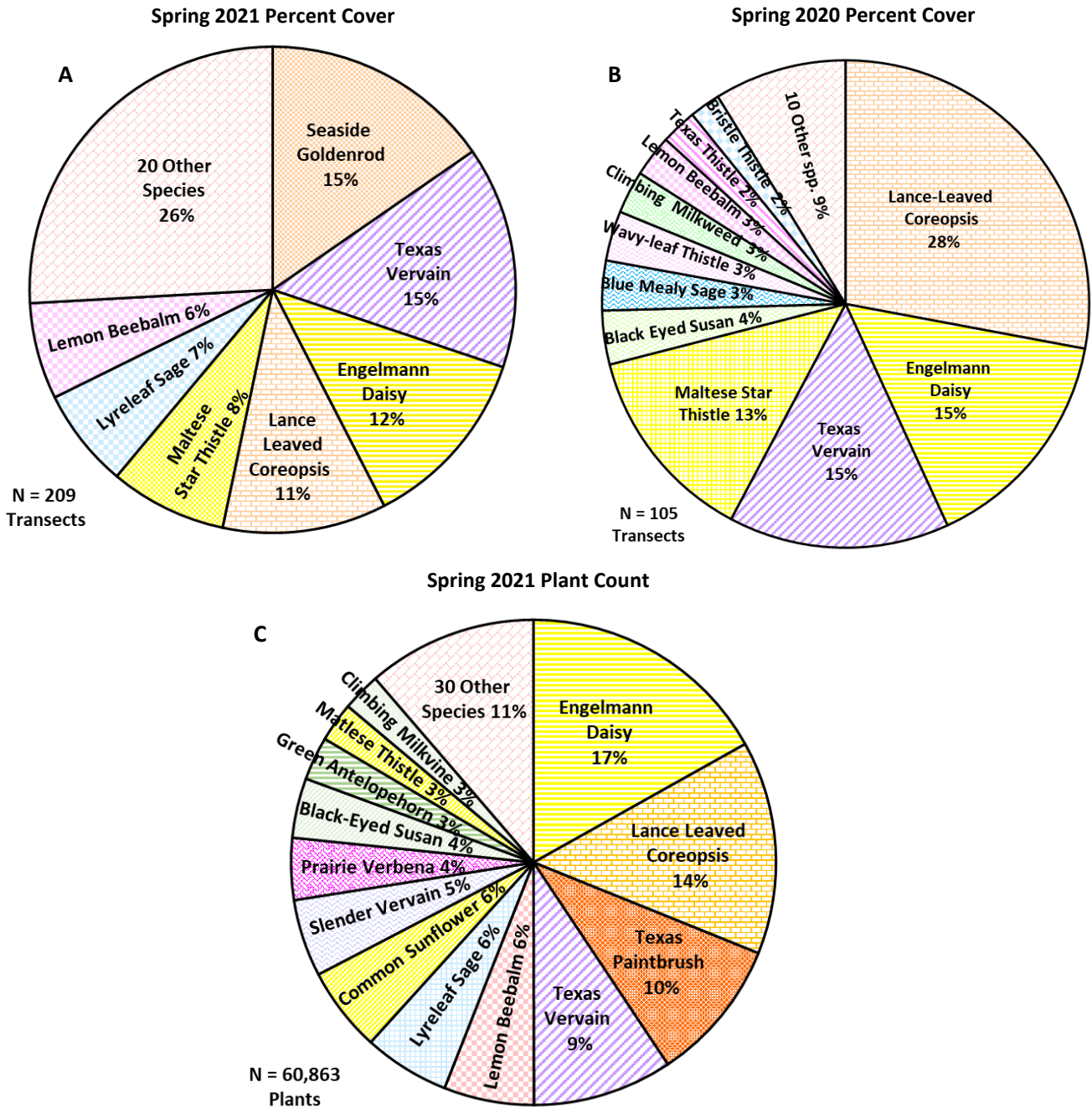


**Figure 20. Spearman’s rank order correlation ( $r_s$ ) between monarch roadkill per 100m x 5 m roadside transect and milkweed plants per 100m x 10 m transect for (A) spring 2021; (B) spring 2020; and (C) fall 2020.**





**Figure 21. Spearman’s rank order correlation ( $r_s$ ) between monarch roadkill per 100m x 5 m roadside transect and (A-B) non-milkweed plants per 100m x 10 m transect for (A) spring 2021 and (B) fall 2020; or (C-D) all nectar plant percent cover per 5 x 50 m transect for (C) spring 2021 and (D) fall 2020.**

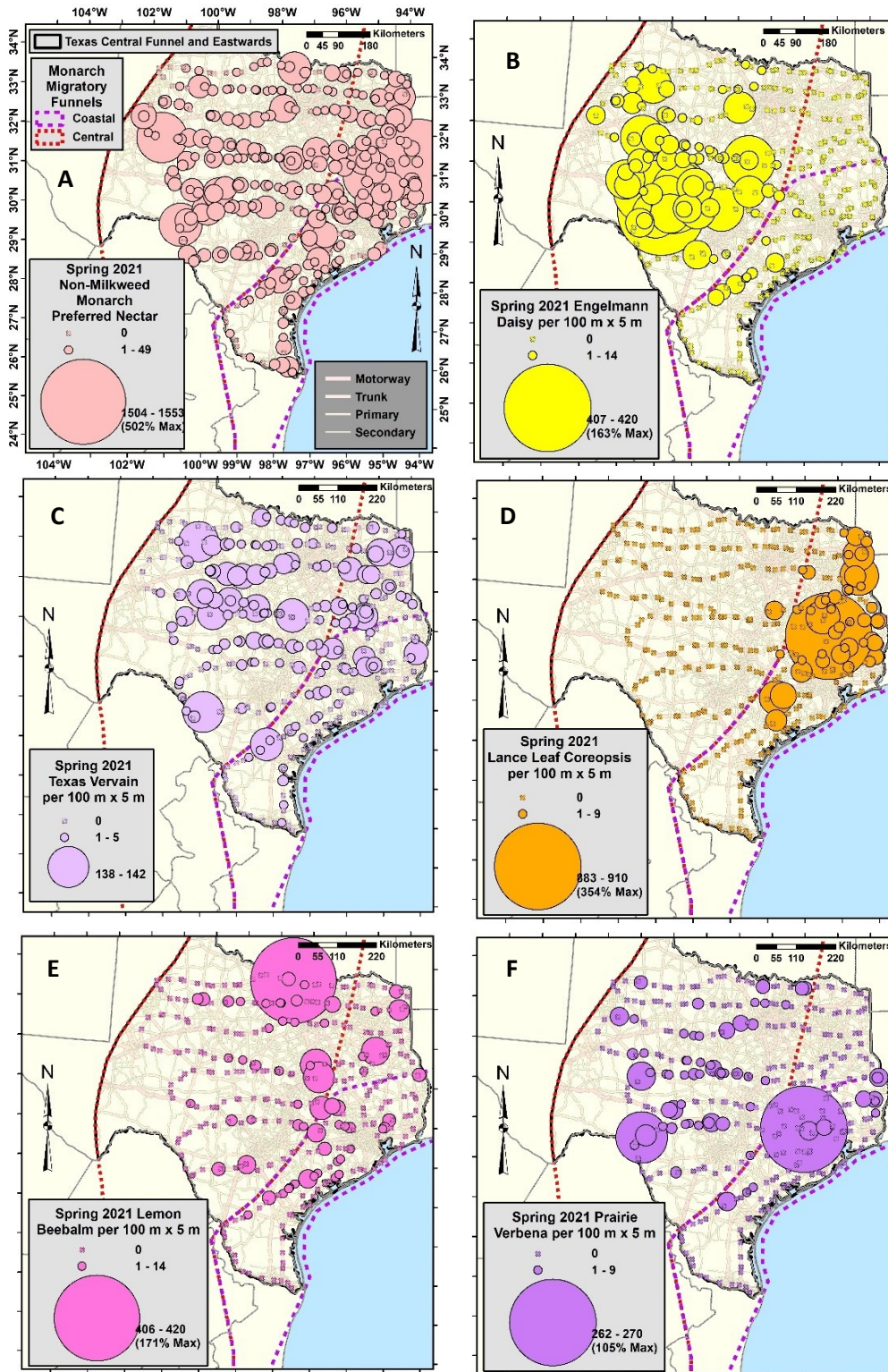


**Figure 22. Percentages of monarch preferred spring nectar plants along transects for Central Funnel and Eastwards in Texas: (A-B) Percent of total mean percent covers per 50 x 5 m dispersed and adventitious transects in (A) Spring 2021 and (B) Spring 2020; and (C) Sum of plant counts over all inner and outer 100 x 5 m transects for Spring 2021.**



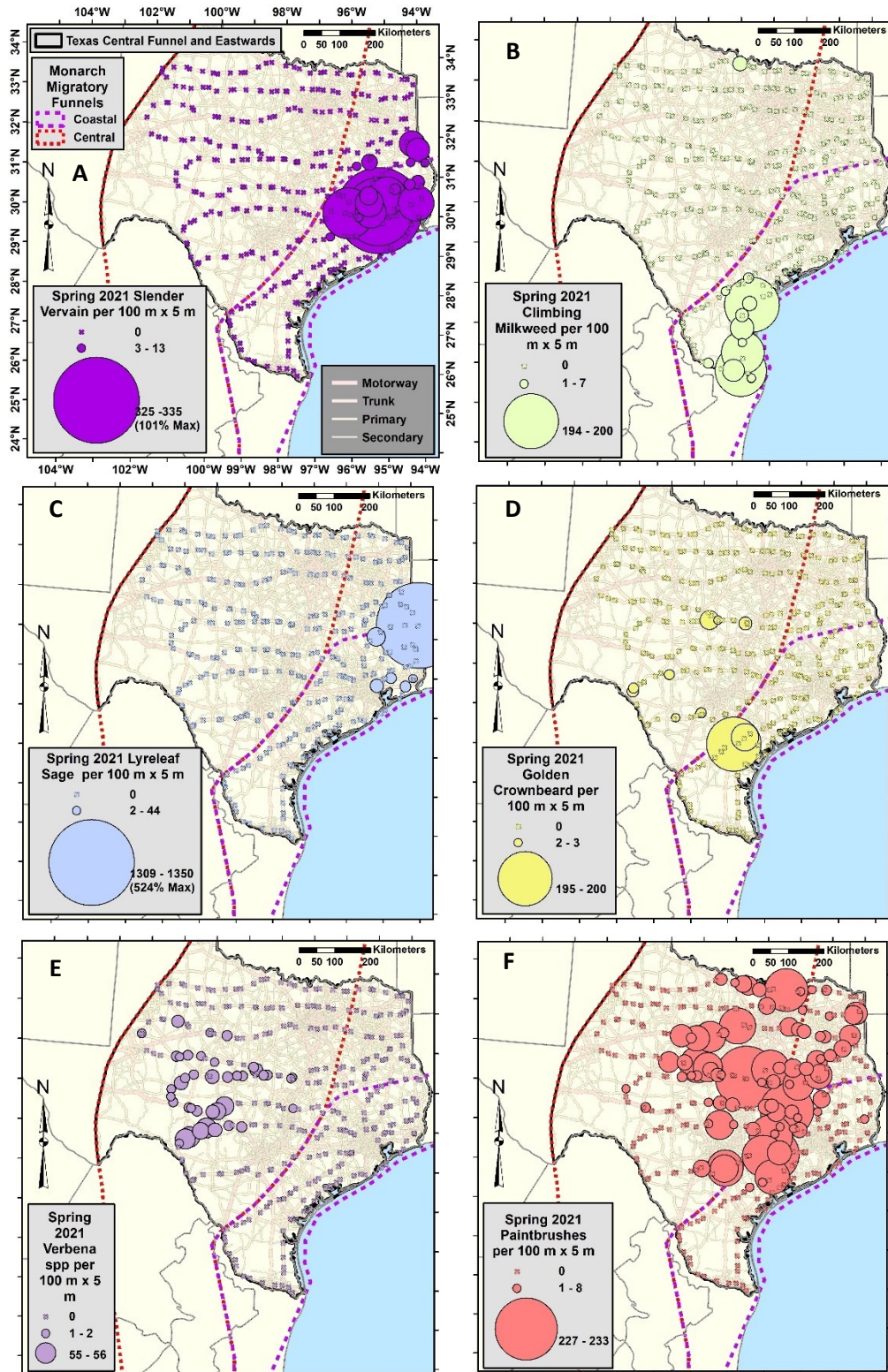
**Figure 23. Major native roadside non-milkweed monarch preferred high-value nectar plants in Texas for March-May 2021: (A) Engelmann daisy, *Engelmannia peristenia*; (B) Lance leaved coreopsis, *Coreopsis lanceolata*; (C) Texas vervain, *Verbena halei*; (D) Lemon beebalm, *Monarda citriodora*; (E) Lyreleaf sage, *Salvia lyrata*; (F) Slender vervain, *Verbena rigida*; (G) Prairie verbena, *Glandularia bipinnatifida*; (H) Climbing milkweed vine, *Funastrum cynanchoides*; and (I) Golden crownbeard, *Verbesina encelioides* (images, iNaturalist 2021).**



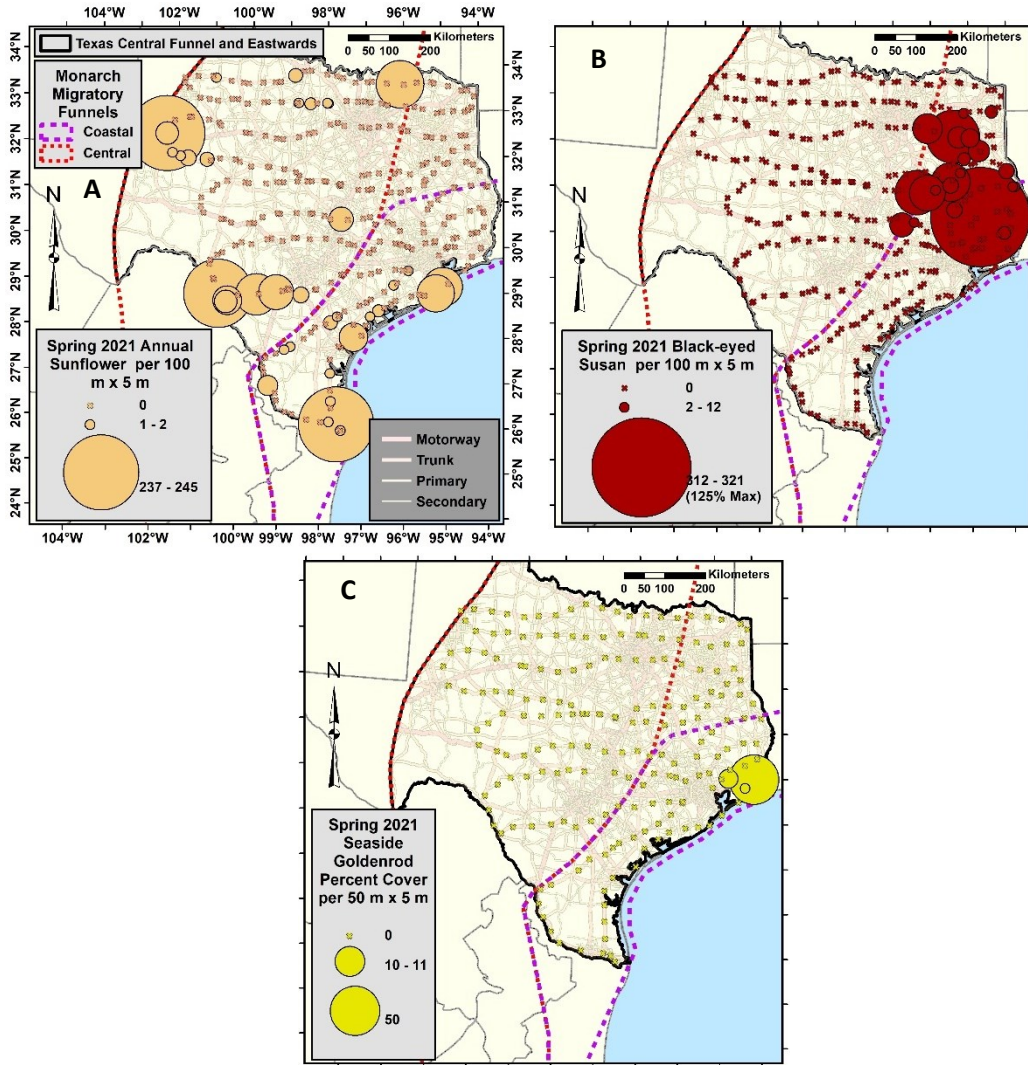


**Figure 24. Distribution of Spring 2021 counts of non-milkweed monarch-preferred nectar plants averaged over all 314 inner and outer 100m x 5m transects (unthinned) in Texas monarch migratory Central Funnel and eastwards for (A) All non-milkweed monarch-preferred nectar species; (B) Engelmann daisy; (C) Texas vervain; (D) Lance leaved coreopsis; (E) Lemon beebalm; and (F) Prairie verbena (symbols ca. proportional among taxa).**



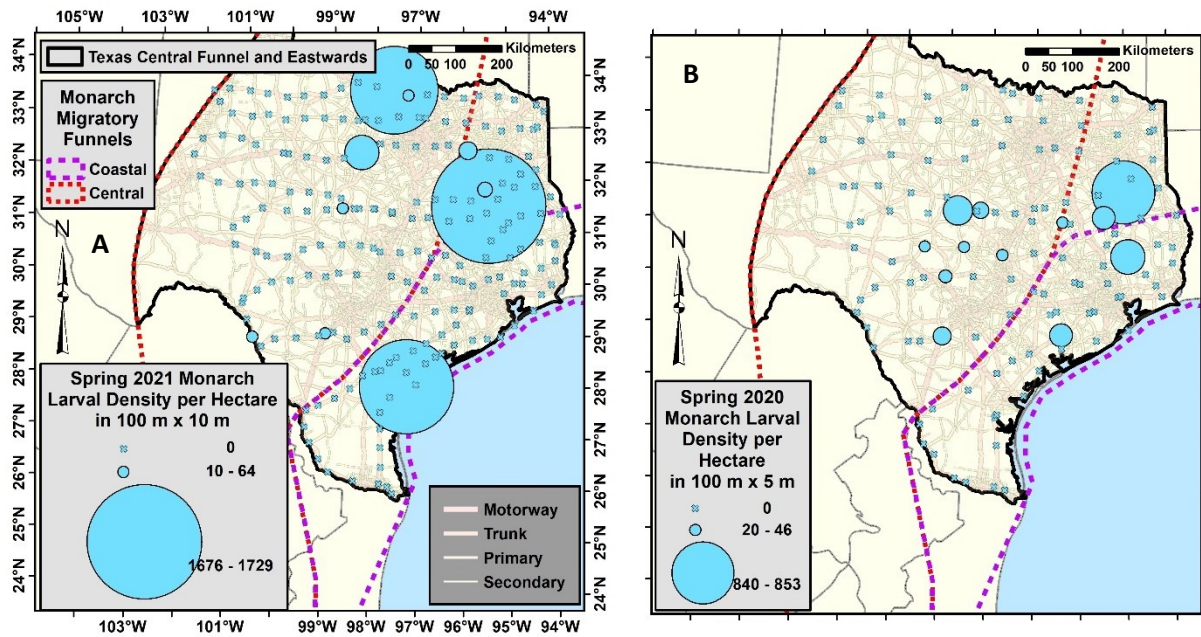


**Figure 25. Distribution of Spring 2021 counts of non-milkweed monarch-preferred nectar plants averaged over all 314 inner and outer 100m x 5m transects (unthinned) in Texas monarch migratory Central Funnel and eastwards for (A) Slender vervain; (B) Climbing milkweed; (C) Lyreleaf Sage; (D) Golden crownbeard; (E) Other Verbena; and (F) Paintbrushes (symbols ca. proportional among taxa).**

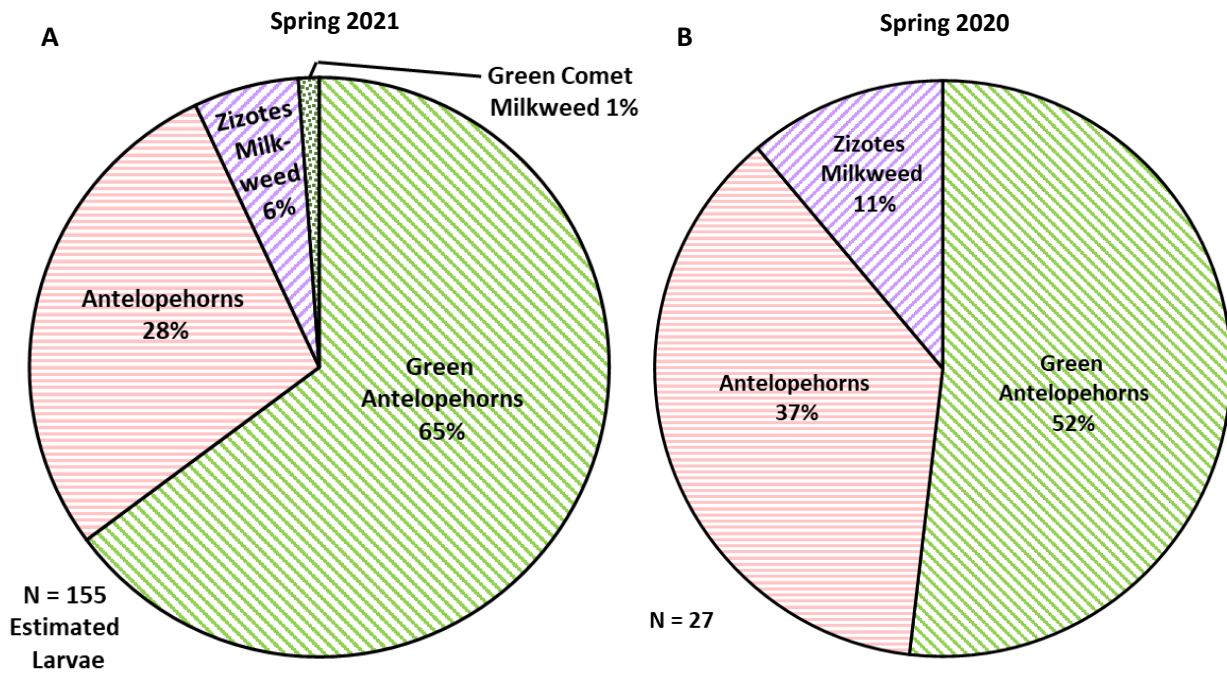


**Figure 26. Distribution of Spring 2021 counts of summer/fall non-milkweed monarch-preferred nectar plants averaged over all 314 inner and outer 100m x 5m transects (unthinned) in Texas monarch migratory Central Funnel and eastwards for (A) Annual sunflower; (B) Black-eyed susan; and (C) percent cover in 196 dispersed 50 m x 5 m transects of seaside goldenrod.**

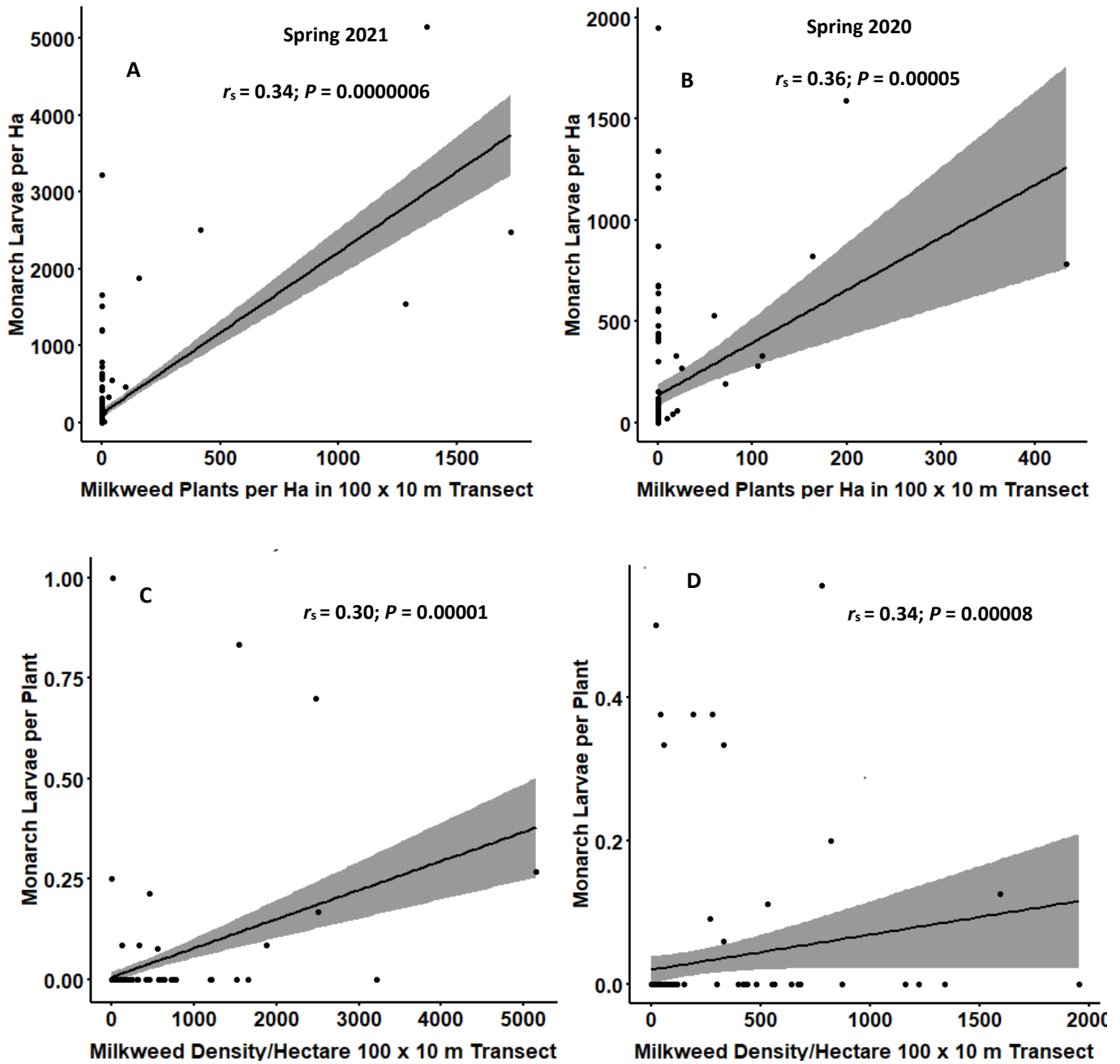




**Figure 27. Distribution of spring densities of monarch larvae per hectare roadside transects (unthinned) for Texas monarch migratory Central Funnel and eastwards (A) 2021 (n = 209 transects), and (B) 2020 (n = 125 transects).**

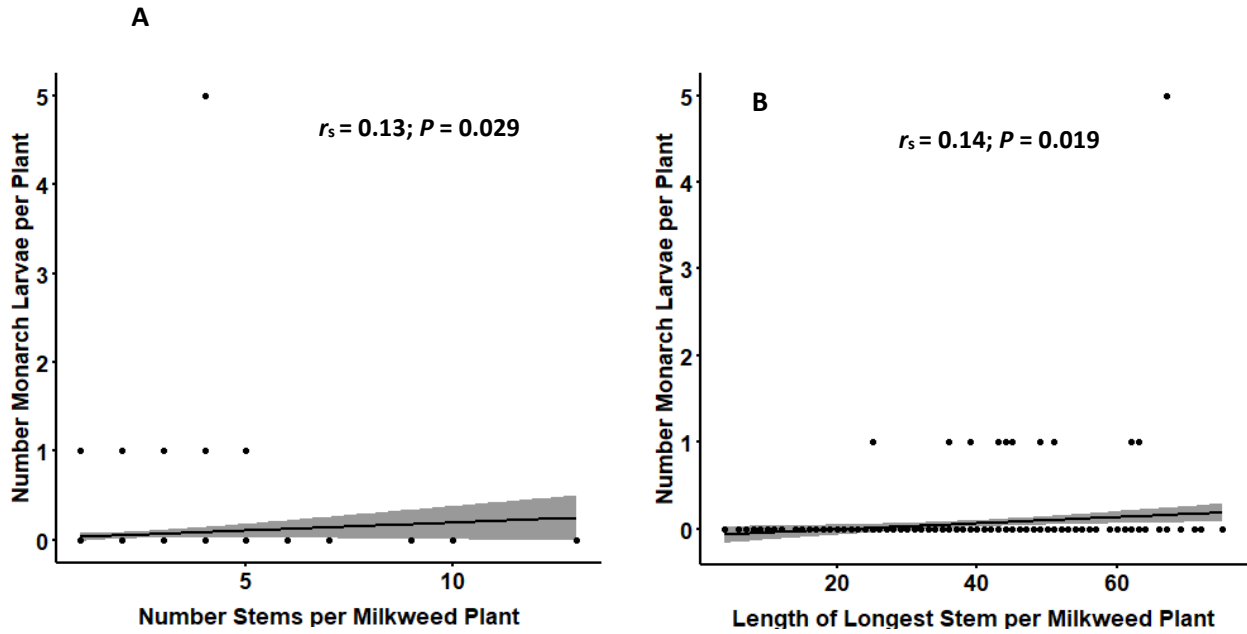


**Figure 28. Percentage monarch larvae among different milkweed species along roadside transects for Central Funnel and Eastwards in Texas (A) March-May 2021; (B) April-May 2020.**



**Figure 29. Spearman’s rank order correlation ( $r_s$ ) between (A-B) monarch larvae per ha and milkweed plants per ha for (A) 2021 ( $r_s = 0.34; P = 0.0000006$ ) and (B) 2020 ( $r_s = 0.36; P = 0.00005$ ), and (C-D) monarch larvae per plant and milkweed plants per ha for (C) 2021 ( $r_s = 0.30; P = 0.00001$ ), and (D) 2020 ( $r_s = 0.34; P = 0.00008$ ).**





**Figure 30. Spearman’s rank order correlation ( $r_s$ ) between monarch larvae per green antelopehorn (*Asclepias viridis*) plant and (C) number of stems per plant ( $r_s = 0.13; P = 0.029$ ), and (D) length of longest stem per plant ( $r_s = 0.14; P = 0.019$ ).**

## References

- Ajilvsgi, G. 2013. *Butterfly Gardening for Texas* (No. 46). Texas A&M University Press.  
Available at:  
[https://books.google.com/books?id=IWhdACADM58C&printsec=frontcover&source=gbs\\_ge\\_summary\\_r&cad=0#v=onepage&q=monarch&f=false](https://books.google.com/books?id=IWhdACADM58C&printsec=frontcover&source=gbs_ge_summary_r&cad=0#v=onepage&q=monarch&f=false)
- Geofabrik (2017) OpenStreetMap Data Extracts. Accessed at:  
<http://download.geofabrik.de/>
- Halbritter, D.A., Daniels, J.C., Whitaker, D.C. and Huang, L. 2015. Reducing mowing frequency increases floral resource and butterfly (Lepidoptera: Hesperioidea and Papilionoidea) abundance in managed roadside margins. *Florida Entomologist*, 98(4):1081-1092.
- Hartzler, R. G., and Buhler, D. D. 2000. Occurrence of common milkweed (*Asclepias syriaca*) in cropland and adjacent areas. *Crop Protection*, 19(5):363-366.
- Hartzler, Robert G. 2010. Reduction in common milkweed (*Asclepias syriaca*) occurrence in Iowa cropland from 1999 to 2009. *Crop Protection*, 29(12):1542-1544.
- iNaturalist. 2021. *Observations*. Accessed at: <https://www.inaturalist.org/observations/>
- Kantola, T., Tracy, J.L., Baum, K.A., Quinn, M.A., and Coulson, R.N. 2019. Spatial risk assessment of eastern monarch butterfly road mortality during autumn migration within the southern corridor. *Biological Conservation*, 231:150-160.
- Kasten, K., Stenoien, C., Caldwell, W. and Oberhauser, K.S. 2016. Can roadside habitat lead monarchs on a route to recovery?. *Journal of Insect Conservation*, 20(6):1047-1057.
- Kaul, A.D. and Wilsey, B.J. 2019. Monarch butterfly host plant (milkweed *Asclepias* spp.) abundance varies by habitat type across 98 prairies. *Restoration Ecology*, 27(6):1274-1281.
- McKenna, D.D., McKenna, K.M., Malcom, S.B., and Berenbaum, M.R. 2001. Mortality of Lepidoptera along roadways in central Illinois. *Journal of Lepidopterists' Society*, 55 (2): 63-68.
- Pleasants, J.M. and Oberhauser, K.S. 2013. Milkweed loss in agricultural fields because of herbicide use: effect on the monarch butterfly population. *Insect Conservation and Diversity*, 6(2):135-144.
- Pollinator Partnership. 2013. *Monarch Habitat Development on Utilities Rights of Way*. 32 pp. Available at:

<https://www.pollinator.org/pollinator.org/assets/generalFiles/Monarch.Habitat.Manual.ROW.SouthEast.ver3.pdf>

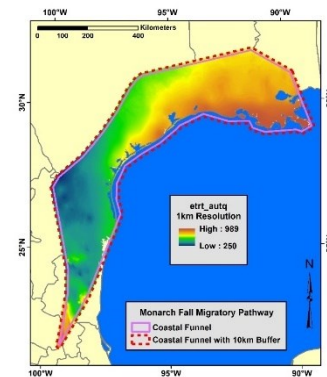
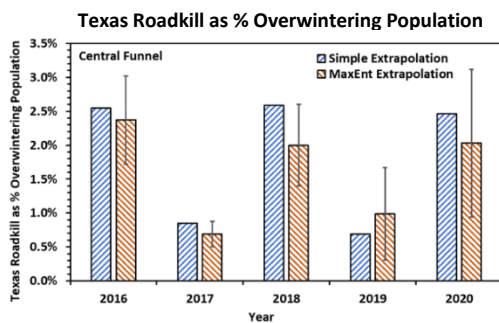
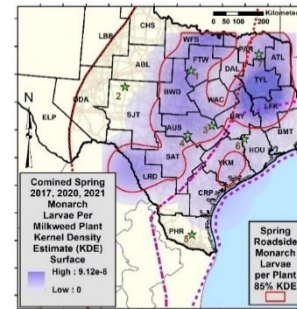
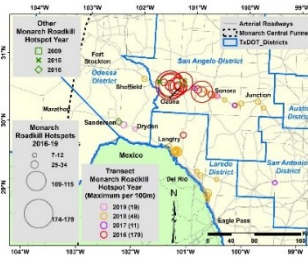
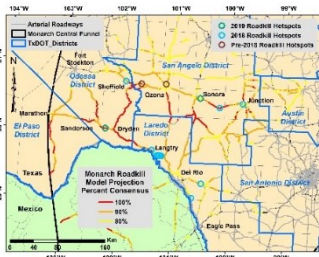
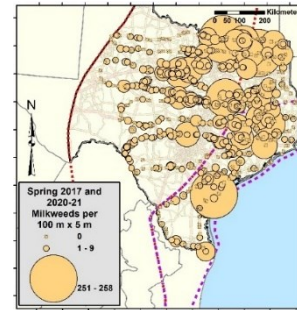
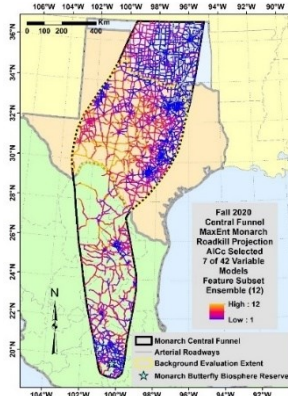
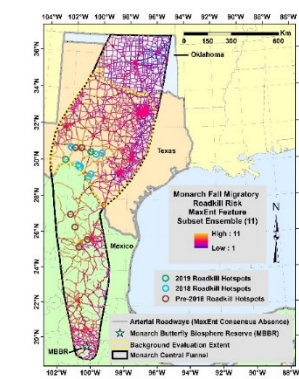
Singhurst J., Hutchins B., and Holmes W.C. 2015. *Identification of milkweeds (Asclepias, Family Apocynaceae) in Texas*. Texas Parks and Wildlife and Lady Bird Johnson Wildflower Center, University of Texas, Austin, Texas, 48 pp. Available at: <https://www.wildflower.org/plants/TPWD-Identification-Milkweeds-Texas.pdf>

US Department of Agriculture NRCS. 2018. *Important Plants of the Monarch Butterfly, Southern Great Plains: Staff Guide*. Monarch butterflies plant lists: Southern plains; Kansas, Oklahoma, and Texas. 100 pp Available at: [https://www.nrcs.usda.gov/wps/PA\\_NRCSConsumption/download?cid=nrcseprd772806&ext=pdf](https://www.nrcs.usda.gov/wps/PA_NRCSConsumption/download?cid=nrcseprd772806&ext=pdf)

US Department of Transportation, Federal Highway Administration (USDOT-FHWA). 2013. *Highway Functional Classification Concepts, Criteria and Procedures*. Accessed at: [https://www.fhwa.dot.gov/planning/processes/statewide/related/highway\\_functional\\_classifications/fcauab.pdf](https://www.fhwa.dot.gov/planning/processes/statewide/related/highway_functional_classifications/fcauab.pdf)

USDOT-FHWA. 2020. *HPMS [Highway Monitoring Performance System] Public Release of Geospatial Data in Shapefile Format*. Polyline shapefiles for US states for 2017 including AADT and Traffic Speed. Accessed at: <https://www.fhwa.dot.gov/policyinformation/hpms/shapefiles.cfm>

# PART III: TEXAS MONARCH ROADKILL NICHE MODELS FOR TEXAS





## PREFACE TO PART III

Part III presents results from modeling of 2019-2021 Texas spring and fall monarch roadkill. Chapters 1 and 4 present MaxEnt niche models for fall 2019 and fall 2020 monarch roadkill, respectively. Chapter 3 provides a combined four year Texas monarch roadkill MaxEnt niche model for fall 2016-2019. Chapter 6 develops roadkill kernel density estimate (KDE) models of spring Texas monarch roadkill from 2017, 2020 and 2021, including KDE models of milkweeds and monarch larvae. Appendix A details the development of GIS layers used in the MaxEnt roadkill models.

## EXECUTIVE SUMMARY

Five continuous years of MaxEnt model projections for fall monarch roadkill in the Texas Central Funnel from 2016 to 2020 agree with simple extrapolations in revealing a biennial cycle of higher roadkill in the even-numbered years of 2016, 2018, and 2020, representing about 2.5% of the monarch overwintering population. In contrast, roadkill represented only 0.8% of the overwintering population in odd-numbered years of 2017 and 2019. Annual MaxEnt monarch roadkill models generally agree in projecting perennial monarch roadkill hotspot regions in both the Texas Central and Coastal Funnels. Spring monarch roadkill was never more than half the fall monarch roadkill seen in odd numbered years and could be less than 10% of that seen in even numbered years.

Combined spring 2017, 2020, and 2021 densities of roadside monarch larvae, monarch roadkill, and milkweeds were generally highest in the northeastern Central Funnel, northern Coastal Funnel and Northeast Texas. These areas should be the focus of habitat enhancement for indirect compensatory monarch roadkill mitigation to increase monarch populations, along with milkweed poor South Texas.

## CHAPTER 1. INTRODUCTION

Significant monarch butterfly road mortality has been documented during the fall from 2016 to 2019 in Texas (Kantola et al. 2019, Tracy and Coulson 2019) and Mexico (Mora Alvarez et al. 2019, Part II Chapter 2). Previous estimates of monarch road mortality from MaxEnt niche models for the fall migratory Central Funnel from Texas to Mexico represent from 1-4% of the overwintering population in Mexico. Much of the mortality in Texas occurs in the southwestern portion of the Central Funnel from Junction to Sheffield and south to Eagle Pass (Kantola et al. 2019, Tracy and Coulson 2019). Further study is needed to understand the yearly variation in the degree and location of monarch roadkill in Texas. The roadside densities of spring monarch roadkill, monarch larvae, and milkweeds in Texas are important indicators of where monarchs are present and potentially utilizing available roadside milkweeds for nectaring and as larval host plant resources. Identifying high and low-value monarch roadside regions is important for identifying areas for conserving and enhancing roadside monarch milkweed habitats and migratory connectivity through Texas.

The primary objectives for Part III were to utilize monarch roadkill field mortality data from the fall of 2019 and 2020 to develop MaxEnt niche models to characterize monarch roadkill distribution and estimate total roadkill in Texas and the Central and Coastal funnels. In addition, Texas fall monarch roadkill from four years of 2016 to 2019 are combined to develop more robust multi-year MaxEnt roadkill niche models. The spatio-temporal distribution of monarch roadkill hotspots are also analyzed for 2016-2019 in the Texas Central Funnel, and 2018 in the Texas Coastal Funnel.

Additionally, we newly analyze spring 2017 data from a previous study (Kantola et al. 2019) with spring 2020 and 2021 data from the current study (Part II Chapters 3 and 5) to map the distribution and density of Texas spring monarch roadkill and roadside monarch larvae and milkweeds. We also develop kernel density estimate (KDE) surface models to reveal combined year density distributions. Monarch resource density distribution maps and KDE models are used in selecting seven potential locations for establishing roadside milkweed Specialized Management Areas to promote spring migratory connectivity of monarch butterflies (Part I Chapter 9).

### References

Kantola T., Tracy, J.L., Baum, K.A., Quinn, M.A., Coulson, R.N. 2019. Spatial risk assessment of eastern monarch butterfly road mortality during autumn migration within the southern corridor. *Biological Conservation*, 231:150-160.

Mora Alvarez, B.X., Carrera-Treviño, R., and Hobson, K.A. 2019. Mortality of monarch butterflies (*Danaus plexippus*) at two highway crossing “hotspots” during autumn migration in Northeast Mexico. *Frontiers in Ecology and Evolution*, 7: 273.

Tracy J.L., and Coulson R.N. 2019. *Eastern Monarch Butterfly Fall Migratory Roadkill Distribution and Hotspot Regions within the Coastal and Central Migratory Funnels of Texas*. Texas A&M Department of Entomology/Texas Transportation Institute Project Final Report. TxDOT Environmental Affairs Division, Austin, Texas. 32 pp.

Available at:

[https://www.dropbox.com/s/an9wuzkyr54xdb0/TTI\\_TAMU%20Texas%20Monarch%20Roadkill%20Fall%202018%20Report.docx?dl=0](https://www.dropbox.com/s/an9wuzkyr54xdb0/TTI_TAMU%20Texas%20Monarch%20Roadkill%20Fall%202018%20Report.docx?dl=0)



## CHAPTER 2. FALL 2019 MONARCH ROADKILL MODELS

### Summary

Fall 2019 MaxEnt monarch roadkill models for the Central Funnel migratory pathway confirm previous studies identifying highest monarch roadkill in the Junction/Sheffield/Eagle Pass region, from which all previous roadkill hotspots in the Central Funnel have been reported. MaxEnt model estimated roadkill in the Central Funnel for 2019 was 1.2 million, or 2% of the Mexican overwintering population. The percentage of overwintering loss to Central Funnel roadkill in 2019 is about double that estimated for 2017 (1.08%) and about half that estimated for 2016 (3.46%) and 2018 (3.85%), with a range of 1-4% observed over the four years of 2017-2019. Based on the four years of studies to date, potential plans for direct mitigation of monarch roadkill in the Texas Central funnel, such as seasonal lower advisory speed limits, should be focused on the southern portions of the TxDOT San Angelo and Odessa districts and the northern portion of the Laredo district.

### Methods

#### *Monarch Roadkill Observations*

Roadkill observations were made following the same protocol as Kantola et al. (2019), employing 100 x 1 meter transects spaced about every 20-30 km in both the Central and Coastal migratory funnels of Texas (Figs. 1 and 2; for details, see Part II Chapter 2).

#### *Environmental Variables*

Forty-one environmental variables at 30.8 m resolution were developed for modeling roadkill in the Central Funnel (Table 1), which is an expanded combination of the 30 variables employed in each of the two previous studies (Kantola et al. 2019, Tracy and Coulson 2019). The variables include five road indices, four human population indices, 20 topographic indices, eight land cover indices, and four climatic indices (for additional details, see Kantola et al. 2019 and Tracy and Coulson 2019)

#### *MaxEnt Roadkill Niche Models*

Roadkill presence and absence data were independently randomly spatially thinned to 2 km to reduce spatial autocorrelation. The final MaxEnt models chosen by feature selection (see below) were calibrated to binary presence/absence format using a threshold of maximum TSS<sub>pa</sub> (Liu et al. 2013) and combined using frequency consensus to form a feature subset ensemble (for further details, see Tracy and Coulson 2019).

## MaxEnt Roadkill Extrapolations

Estimations of fall monarch roadkill per 100 m for both sides of the roadway were made using transect data from 2016, 2017 (Kantola et al. 2019) and 2018 (Tracy and Coulson 2018) and 2019 (see Part II Chapter 2). We extrapolated the mean roadkill per km count rate (adjusted from 100 m) for the thinned presence point data throughout the Central Funnel by multiplying it with the length of kilometers of roadway with projected roadkill according to each binary MaxEnt presence/absence roadkill model. Binary MaxEnt output rasters were vectorized to polyline shapefiles using the ArcScan extension of ArcGIS (ESRI, Redlands, California) in order to estimate lengths of roadway projected with roadkill.

## Feature Selection

We utilized a modified version of the random subset feature selection algorithm (RSFSA-CV; Tracy et al. 2018) to select a high performing ensemble of MaxEnt roadkill models using different subsets of the 41 environmental variables or predictors. The objective of RSFSA-CV is to produce MaxEnt models exhibiting higher accuracy in terms of presence/absence AUC ( $AUC_{pa}$ ), lower complexity, as measured by corrected Akaike information criterion ( $AIC_{cbg}$ ,  $AIC_c$  computed from background point data), and lower overfitting, as measured by  $AUC_{pa\_diff}$  (training  $AUC_{pa}$  minus test  $AUC_{pa}$ ; Warren and Seifert 2011) than random feature subsets. The RSFSA-CV was used to first select hundreds of random subsets of variables ranging from one to eight of the 41 total variables, with a restriction of  $|0.7|$  for intervariable correlation within each subset. MaxEnt models were developed and evaluated from the various sized random subsets to choose an optimally sized feature subset. Once a variable subset size was chosen, hundreds to thousands of MaxEnt models were developed from random subsets of the chosen size and ranked separately by  $AUC_{pa}$  or  $AIC_{cbg}$  to measure performance against random MaxEnt models of the same feature subset size. Either  $AUC_{pa}$  or  $AIC_{cbg}$  was then chosen to rank the top MaxEnt models for the final roadkill spatial projections. We kept a random 12 models from the top ranked MaxEnt roadkill models, four from each of three RSFSA-CV replications. We jointly ranked the variables in the top feature-selected MaxEnt models for mean variable permutation importance and frequency of variable appearance in the models (for additional details see Tracy et al. 2018, 2019).

## Results and Discussion

### MaxEnt Roadkill Niche Models

A total of 25 out of 111 Central Funnel transects had monarch roadkill in the fall of 2019, ranging from 1 to 16 monarchs per 100 m (Figs. 3-4). About 25 roadkill presence points is close to a minimal number of roadkill records needed for MaxEnt modeling. Central Funnel transects with roadkill ranged from 21 out of 75 in 2017 (Kantola et al. 2019) to

59 out of 86 in 2018 (Tracy and Coulson 2019). Three of 45 Coastal Funnel 100 m transects had two monarch roadkill each in 2019 (Figs. 3-4), which is much lower than 39 out of 97 transects with roadkill in 2018 (Tracy and Coulson 2019). Three roadkill records were insufficient data for MaxEnt modeling of roadkill in the Coastal Funnel for 2019, and only the 2019 Central Funnel roadkill was modeled.

Two of 41 variables appeared to provide Central Funnel MaxEnt roadkill models with the highest accuracy ( $AUC_{pa}$ ), lowest complexity ( $AIC_{cbg}$ ), and lowest overfitting ( $AUC_{pa\_diff}$ ) (Fig. 5A-C). Three RSFSA-CV feature selection replicates with hundreds of two-variable MaxEnt models showed improvement in overfitting of selected versus random models in only some replicates, but no improvement in terms of higher accuracy or lower complexity (Fig. 5D-F). The  $AIC_{cbg}$  selected models showed the most improvement in overfitting (Fig. 5F), and  $AIC_{cbg}$  was selected as the final ranking criterion.

One of the top 12 selected MaxEnt Central Funnel roadkill models failed to be parameterized (model 6, Table A1), leaving only 11 selected MaxEnt roadkill models. Six of these 11 models (55%) were parameterized by MaxEnt with only one of the two variables. Accuracy performance of the 11 selected MaxEnt Central Funnel roadkill models was marginal, with an average accuracy with respect to the absence points,  $AUC_{pa}$ , of  $0.63 \pm 0.08$  ( $\bar{x} \pm SD$ ). Similar average  $AUC_{pa}$  values were found in previous Central Funnel roadkill MaxEnt models; 0.64 and 0.61 for 2016-2017 (Kantola et al. 2019) and 2018 (Tracy and Coulson 2019), respectively. The average accuracy with respect to background points,  $AUC_{bgp}$  (MaxEnt default AUC), of  $0.72 \pm 0.12$  ( $n = 11$ ) in this study was much lower than  $AUC_{bgp}$  of 0.86 in both previous studies (Kantola et al. 2019, Tracy and Coulson 2019).

All five categories of indices were important in the monarch roadkill niche modelling (Table 1). Among the ten highly ranked variables in the feature selected MaxEnt models, three were road indices, two were land cover indices, two were human population indices, two were topographic indices, and one was a climatic index (Table 2). The highest ranked variable of annual precipitation, *prec\_ann*, was in the same correlation group as autumn evapotranspiration ratio, *etr\_autq*, used in the models. There was higher predicted roadkill at lower values *etr\_autq* (Fig. 6A), indicating fall monarch roadkill was associated with more arid areas as found in Kantola et al. (2019). The second and third top ranked variables of percent cover artificial surfaces within 500m, *artsur500mr*, and human population density, *popden*, were also important in models of Kantola et al. (2019). The response curve for the human population density variable of distance to urban areas, *hiurbdist*, revealed greater monarch roadkill was associated with lower population densities (Fig. 6B), and this relationship was seen in both previous studies (Kantola et al. 2019, Tracy and Coulson 2019). Other MaxEnt roadkill model variable response curves indicated higher roadkill in proximity to primary roadways (*primrddist*, Fig. 6C), shrublands (*shrub\_500mr*, Fig. 6D), lower road density areas

(*roadden500mr*, Fig. 6E), and areas of lower topographic soil wetness (*mncti500mr*, Fig. 6F).

The 80, 90, and 100 percent overlap of the top 11 Central Funnel Maxent roadkill models predicted highest monarch roadkill in the southwestern portion of the Central Funnel in Texas (Figs. 7-9). This area includes arid, sparsely populated shrublands from Junction to Sheffield and Eagle Pass (Fig. 9), comprising the southern portion of the TxDOT San Angelo and Odessa districts, and the northern portion of the Laredo District (Fig. 9). This same region was also projected to have the highest monarch roadkill by MaxEnt models from previous 2016-2018 studies (Kantola et al. 2019, Tracy and Coulson 2019). The southeastern portion of the El Paso district was also projected to have high roadkill west of Sanderson and south of Marathon, but this area has not yet been included in monarch roadkill surveys (Fig. 9).

The southwestern Texas Central Funnel region is the only area where monarch roadkill hotspots with 10 or more dead monarchs per 100 m (Fig. 2C) were found in in 2019, and the only area with Central Funnel hotspots in previous years (Figs. 8-9). Tracy and Coulson (2019) identified this monarch roadkill hotspot area as the Junction/Sheffield/Eagle Pass Hotspot Region. The number of Central Funnel hotspots found per year vary from none in 2017 to over 14 in 2016 and 2018 (Kantola et al. 2017, Tracy and Coulson 2019), with only two Central Funnel hotspots found in 2019 (see Part II Chapter 2 for discussion of specific 2019 monarch roadkill hotspots).

### *MaxEnt Roadkill Extrapolations*

Total estimated fall 2019 monarch roadkill in the Central Funnel and Texas portion of the Central Funnel using MaxEnt models was 1.22 and 0.67 million dead monarchs, respectively (Table 3). These figures are larger than the corresponding simple road type roadkill extrapolation estimates of 0.74 and 0.41 million monarch roadkill (Part II Chapter 2). The MaxEnt estimated percentage of the Mexican overwintering population lost by roadkill for 2019 was 2.04% and 1.12% for the entire Central Funnel and the Texas Central Funnel, respectively. The MaxEnt estimated percent overwintering population lost to Central Funnel roadkill in 2017 was 1.08% (Kantola et al. 2019), which is about half of that in 2019 (Table 3). Corresponding MaxEnt estimated percent losses to roadkill for the overwintering population in both 2016 and 2018 were about double that observed in 2017 and 2019 (Table 3) (Kantola et al. 2019, Tracy and Coulson 2019). The Central Funnel percent roadkill loss for the monarch overwintering population fluctuated between about 1% to 3.9% from 2016 to 2019 (Table 3).

### *Conclusion*

The four years of Texas Central Funnel monarch fall roadkill MaxEnt models generally agree in projecting highest roadkill for the Junction/Sheffield/Eagle Pass hotspot region, from which all previous Central Funnel monarch roadkill hotspots have been recorded.



Monarch roadkill hotspots could be found in this region of the Central Funnel in three out of four years, but their location was variable. Potential direct monarch roadkill mitigation, such as seasonal advisory reduced speed limits, should be focused on this region, including the southern portions of the Odessa and San Angelo TxDOT districts and the northern portion of the Laredo district. Planned fall 2020 roadkill surveys should include the southwestern tip of the El Paso district, which MaxEnt models indicate may also have roadkill hotspots in some years.

## Tables

**Table 1. Forty-one environmental predictor indices (30.8 m resolution) evaluated for developing monarch roadkill models.**

Variable Index	Abbreviation <sup>a</sup>	Source
<b>Five Road Indices</b> (based on three major road types of highways, primary roads, and secondary roads)		
Road density, km road in 500 m circular radius (km/0.78 km <sup>2</sup> ) <sup>b</sup>	<i>roadden500mr*</i>	Derived from OpenStreetMap (Geofabrik, 2017)
Road density, km road in 3 km circular radius (km/28 km <sup>2</sup> ) <sup>b</sup>	<i>roadden3kr</i>	"
Distance to highways (motorways and trunks) (m)	<i>highwaydist</i>	"
Distance to primary roads (m)	<i>primrddist*</i>	"
Distance to secondary roads (m)	<i>secrddist</i>	"
<b>Four Human Population Density Indices</b>		
Human population density per km <sup>2</sup>	<i>popden</i>	CIESIN (2016)
Human population density per km <sup>2</sup> in 3 km circular radius (population/28 km <sup>2</sup> ) <sup>b</sup>	<i>mnpopden3kr</i>	Derived from CIESIN (2016)
Human population density per km <sup>2</sup> in 9 km circular radius (population/254.5 km <sup>2</sup> ) <sup>b</sup>	<i>mnpopden9kr*</i>	"
Distance to urban areas ≥ 300 humans per km (km)	<i>hiurbdist*</i>	"
<b>Twenty Topographic Indices</b>		
Aspect	<i>aspect</i>	Derived from 1 arc second resolution SRTM elevation (NASA JPL 2013)
Compound Topographic Index (CTI) <sup>c</sup>	<i>cti</i>	"
Curvature (standard combination of profile and planform curvature)	<i>curv</i>	"
Dissection, 90 m circular radius <sup>c</sup>	<i>diss90mr*</i>	"
Elevation (m)	<i>elev*</i>	NASA JPL (2013)
Elevation Relief Ratio, 30 m circular radius <sup>c</sup>	<i>err30mr</i>	Derived from 1 arc second resolution

**Table 1. Forty-one environmental predictor indices (30.8 m resolution) evaluated for developing monarch roadkill models.**

Variable Index	Abbreviation <sup>a</sup>	Source
		SRTM elevation (NASA JPL 2013)
Latitude (decimal degrees × 10,000)	<i>latitude</i>	
Mean CTI, 500 m circular radius <sup>b</sup>	<i>mncti500mr*</i>	"
Mean CTI, 3 km circular radius <sup>b</sup>	<i>mncti3kr</i>	"
Mean Flow Accumulation, 500 m circular radius <sup>d</sup>	<i>mnfloacc500mr</i>	"
Mean Flow Accumulation, 3 km circular radius <sup>d</sup>	<i>mnfloacc3kmr</i>	"
Mean Slope, 50 m circular radius <sup>b</sup>	<i>mnslope50mr</i>	"
Mean Slope, 150 m circular radius <sup>b</sup>	<i>mnslope150mr</i>	"
Sea Distance (m)	<i>seadist*</i>	"
Site Exposure Index (SEI) <sup>c</sup>	<i>sei</i>	"
Slope	<i>slope</i>	"
Slope Cosine Aspect Index (SCAI) <sup>c</sup>	<i>scai</i>	"
Topographic Position Index (TPI), 30 m circular radius <sup>b,c</sup>	<i>tpi30mr</i>	"
TPI, 90 m circular radius <sup>b,c</sup>	<i>tpi90mr</i>	"
TPI, 300 m circular radius <sup>b,c</sup>	<i>tpi300mr</i>	"
<b>Eight 2010 Globeland30 Land Cover Indices (percent cover in 500 m radius window × 1000; area/0.78km<sup>2</sup>)</b>		
		Globeland30 (Chen et al. 2015)
Artificial surfaces	<i>artsur_500mr</i>	
Barren lands	<i>bare_500mr</i>	"
Cultivated land	<i>cult_500m*</i>	"
Forests	<i>forest_500mr*</i>	"
Grasslands	<i>grslnd_500mr</i>	"
Shrublands	<i>shrub_500mr*</i>	"

**Table 1. Forty-one environmental predictor indices (30.8 m resolution) evaluated for developing monarch roadkill models.**

Variable Index	Abbreviation <sup>a</sup>	Source
Water bodies	<i>water_500mr</i>	"
Wetland	<i>wetInd_500mr</i>	"
<b>Four Climatic Indices<sup>e</sup></b>		
Autumn quarterly mean monthly maximum temperature (°Celsius)	<i>tmax_autq</i>	for 1960–1990 derived from WorldClim (2017) of Hijmans et al. (2005)
Annual mean monthly rainfall (mm)	<i>prec_ann</i>	"
Autumn quarterly mean monthly actual evapotranspiration/potential evapotranspiration × 1000	<i>etr_t_autq*</i>	"
Autumn mean quarterly wind speed (m/second)	<i>wmsp_autq*</i>	for 1970–2000 derived from WorldClim2 (2017) of Fick and Hijmans (2017)

<sup>a</sup>Asterisks indicate variables utilized in feature selected MaxEnt monarch roadkill niche models (see Table A1).

<sup>b</sup>Variables of different scales (radii) can perform differently in niche models (e.g., Bellamy and Altringham 2013).

<sup>c</sup>Calculated using Geomorphometry and Gradient Metrics Toolbox for ArcGIS (Evans et al. 2014).

<sup>d</sup>Flow accumulation for a grid cell is defined by the number of upslope cells from which water can be accumulated, as calculated by ArcGIS software Flow accumulation tool.

<sup>e</sup>Autumn quarter includes October, November, and December.



**Table 2. Monarch Central Funnel roadkill MaxEnt model 10 top ranked variables across variable correlation groups from three replicates of 41 out of 820 models selected by random subset feature selection.<sup>a</sup>**

Variable (n)	Correlation Group	Joint Ranking <sup>b</sup>	Mean Permutation Importance	Mean Frequency in Models
<i>prec_ann</i> (1)	1	3.0	81.4	3.0
<i>artsur_500mr</i> (1)	2	4.0	82.4	4.0
<i>popden</i> (1)	3	4.0	95.1	3.0
<i>highwaydist</i> (3)	4	6.3 ± 6.7	62.6 ± 32.6	3.3 ± 1.1
<i>slope</i> (2)	5	7.0 ± 0.0	68.9 ± 20.8	2.5 ± 0.7
<i>secrddist</i> (3)	6	7.3 ± 3.8	91.5 ± 11.9	2.3 ± 0.6
<i>tmax_autq</i> (3)	7	8.7 ± 2.3	64.5 ± 26.2	2.7 ± 0.6
<i>scai</i> (1)	8	9.0	36.7	4.0
<i>roadden500mr</i> (3)	9	11.7 ± 10.8	61.5 ± 12.6	2.3 ± 1.2
<i>shrub_500mr</i> (3)	10	12.0 ± 9.6	89.4 ± 14.2	2.0 ± 1.0

<sup>a</sup>For variable abbreviations see Table 1. n = number out of three feature selection replicates in which variable appeared. Only *roadden500mr* and *shrub\_500mr* were used in our randomly selected 11 top models (see Table A1).

<sup>b</sup>Variable joint ranking by combination of permutation importance and frequency in all RSFSA\_CV selected models (c.f., Tracy et al. 2019).

**Table 3. Monarch roadkill estimates per year over the monarch migratory Central funnel using MaxEnt model projections.**

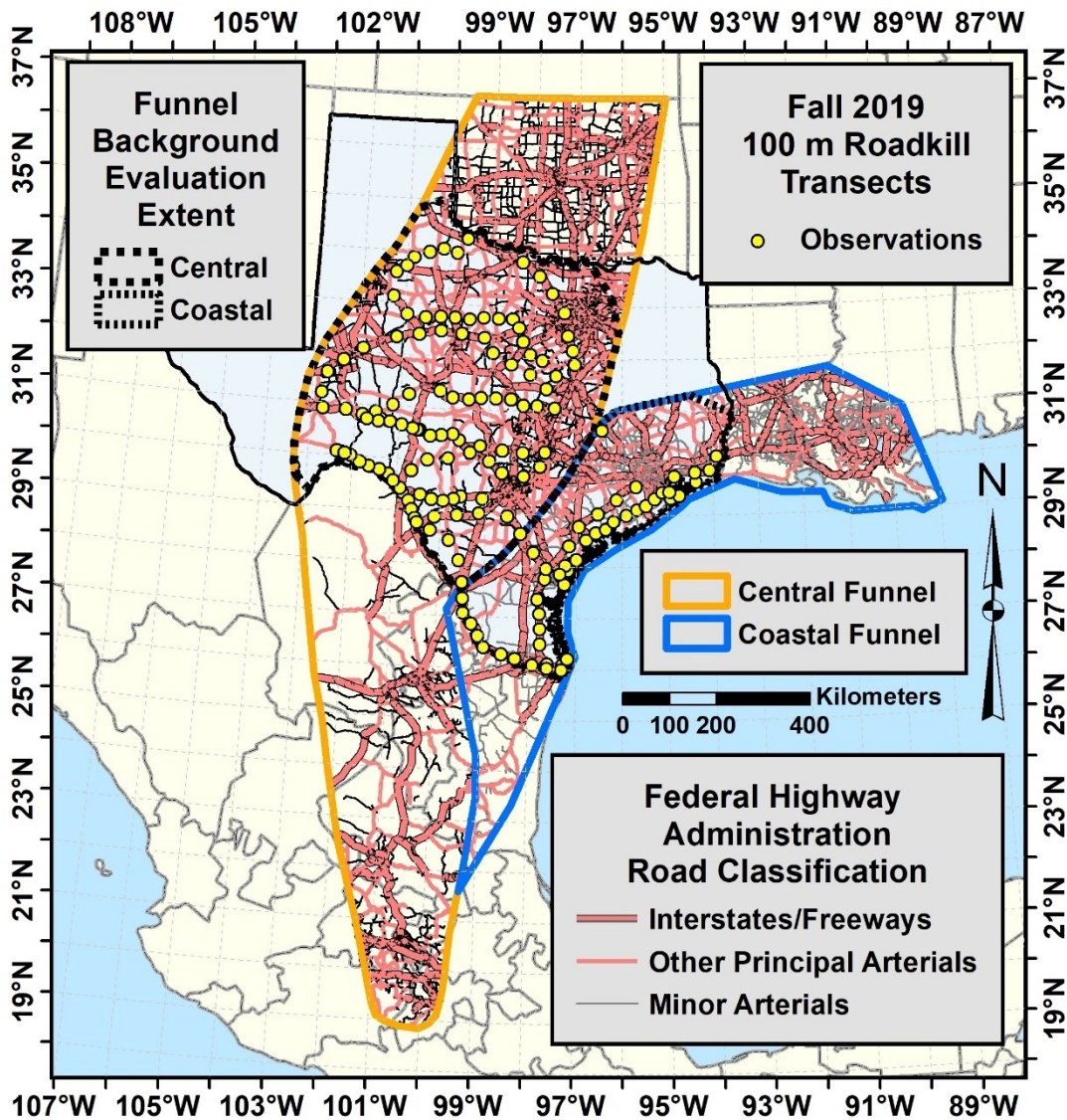
Year (n) <sup>a</sup>	Texas Portion of Central Funnel	Central Funnel
<b>2019 (11) (This Study)</b>		
Kilometers roadways projected with roadkill	16,611 ± 11,434	30,188 ± 19,667
Millions of roadkill <sup>b</sup>	0.67 ± 0.46	1.22 ± 0.79
% Overwintering population <sup>c</sup>	1.12 ± 0.77%	2.04 ± 1.33%
% Funnel mortality	57.40 ± 13.78%	100.00%
<b>2018 (9) (Tracy and Coulson 2019)</b>		
Millions of roadkill	2.55 ± 0.76	4.92 ± 1.68
% Overwintering population	2.00 ± 0.60%	3.85 ± 1.31%
% Funnel mortality	55.01 ± 11.26%	100.00%
<b>2017 (10) (Kantola et al. 2019)</b>		
Millions of roadkill	--	1.08 ± 0.26
% Overwintering population	--	1.73 ± 0.41%
% Funnel mortality	--	100.00%
<b>2016 (10) (Kantola et al. 2019)</b>		
Millions of roadkill	--	3.04 ± 0.74
% Overwintering population	--	3.46 ± 0.82%
% Funnel mortality	--	100.00%

<sup>a</sup>n = number of MaxEnt models.

<sup>b</sup>Mean roadkill rates (roadkill/km/year) of 40.348 monarchs per km with roadkill (4.0348 per 100 m) multiplied by kilometers roadways projected with roadkill by 11 MaxEnt models. Mean roadkill rates calculated from transects of roadkill presence data randomly thinned to 2 km and incorporating estimates for all road edges (see Part II Chapter 2).

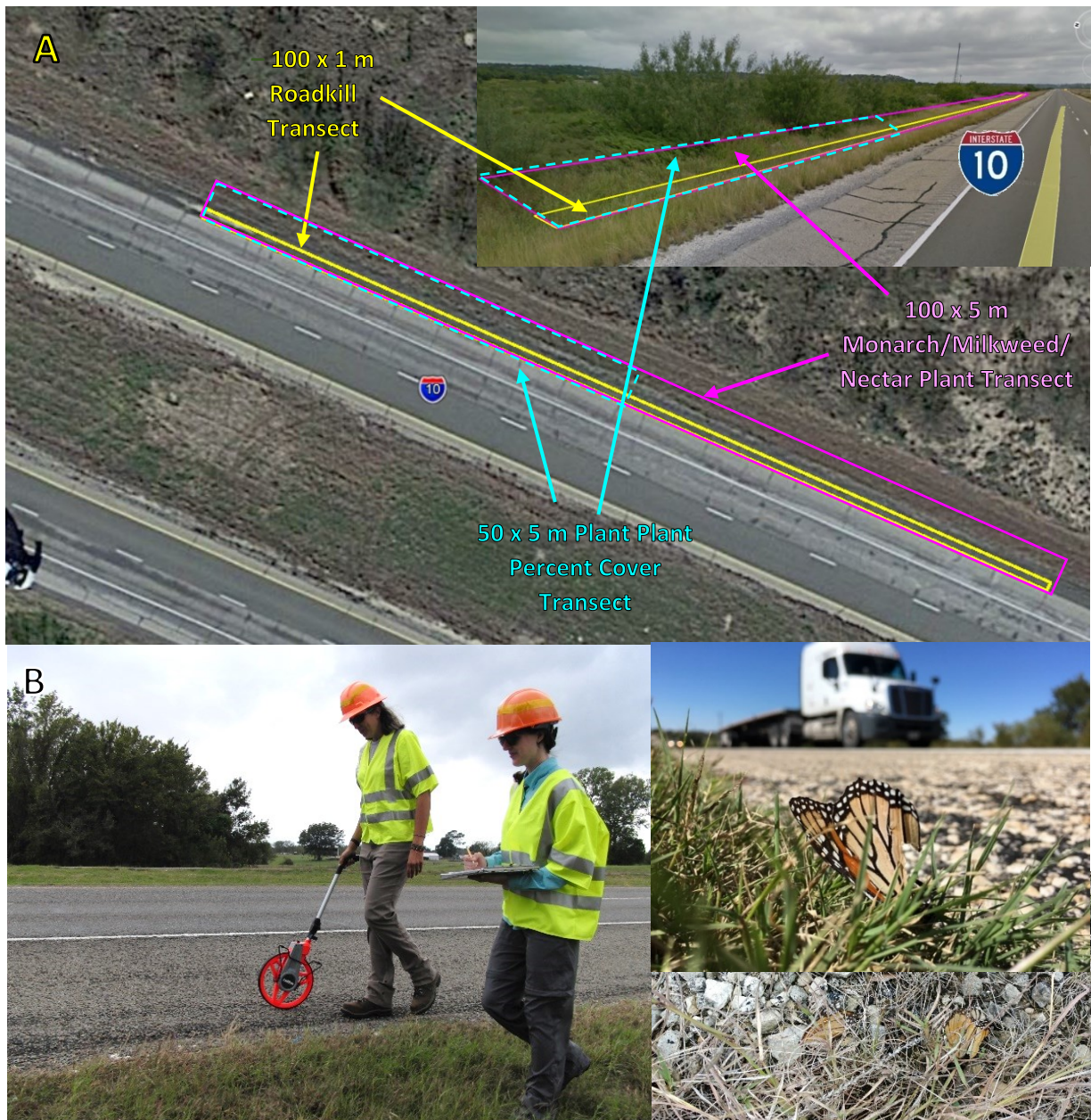
<sup>c</sup>Based on 2019-2020 Mexican overwintering population of 59,713,000 from 2.83 hectares of overwintering monarchs (Monarch Watch 2020) multiplied by 21,100,000 monarchs per hectare (Thogmartin et al. 2017).

## Figures



**Figure 1. Distribution of fall 2019 100 x 1 m roadkill transects over Texas roadways within the monarch migratory Central and Coastal funnels (modified from Tracy et al. 2020 Fig. 1).**





**Figure 2. (A) Layout of 100 x 1 m roadkill transect (yellow), 100 x 5 m monarch/milkweed transect (pink), and 50 x 5 m plant percent cover transect (blue dashed). (B) Field assistants Janice Bovankovich (left) and Kaitlin Lopez (right) walking a 100 m transect. (C) Roadkill monarchs within transects along grassy edge of right of way (from Tracy et al. 2020 Fig. 2)**



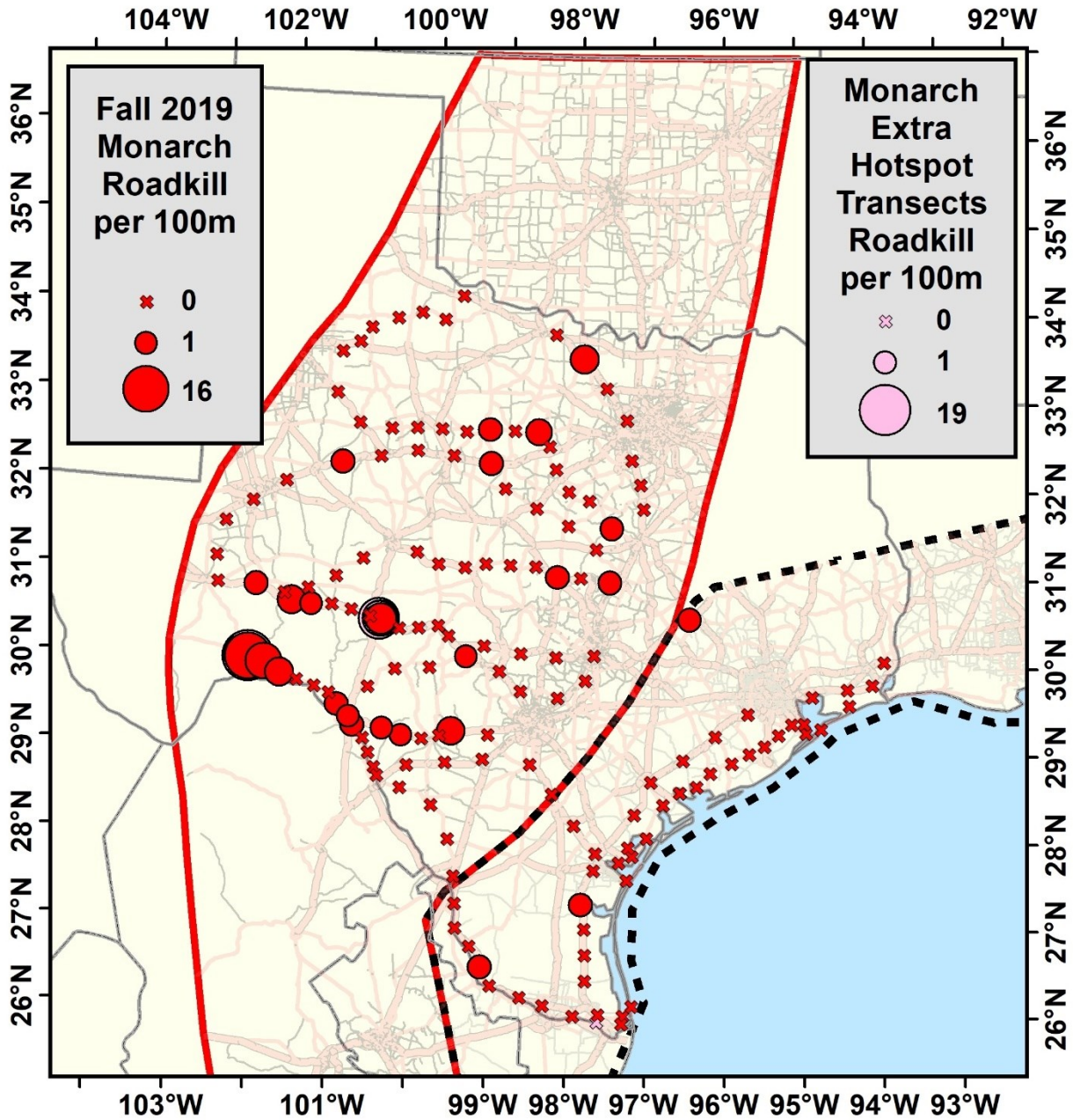
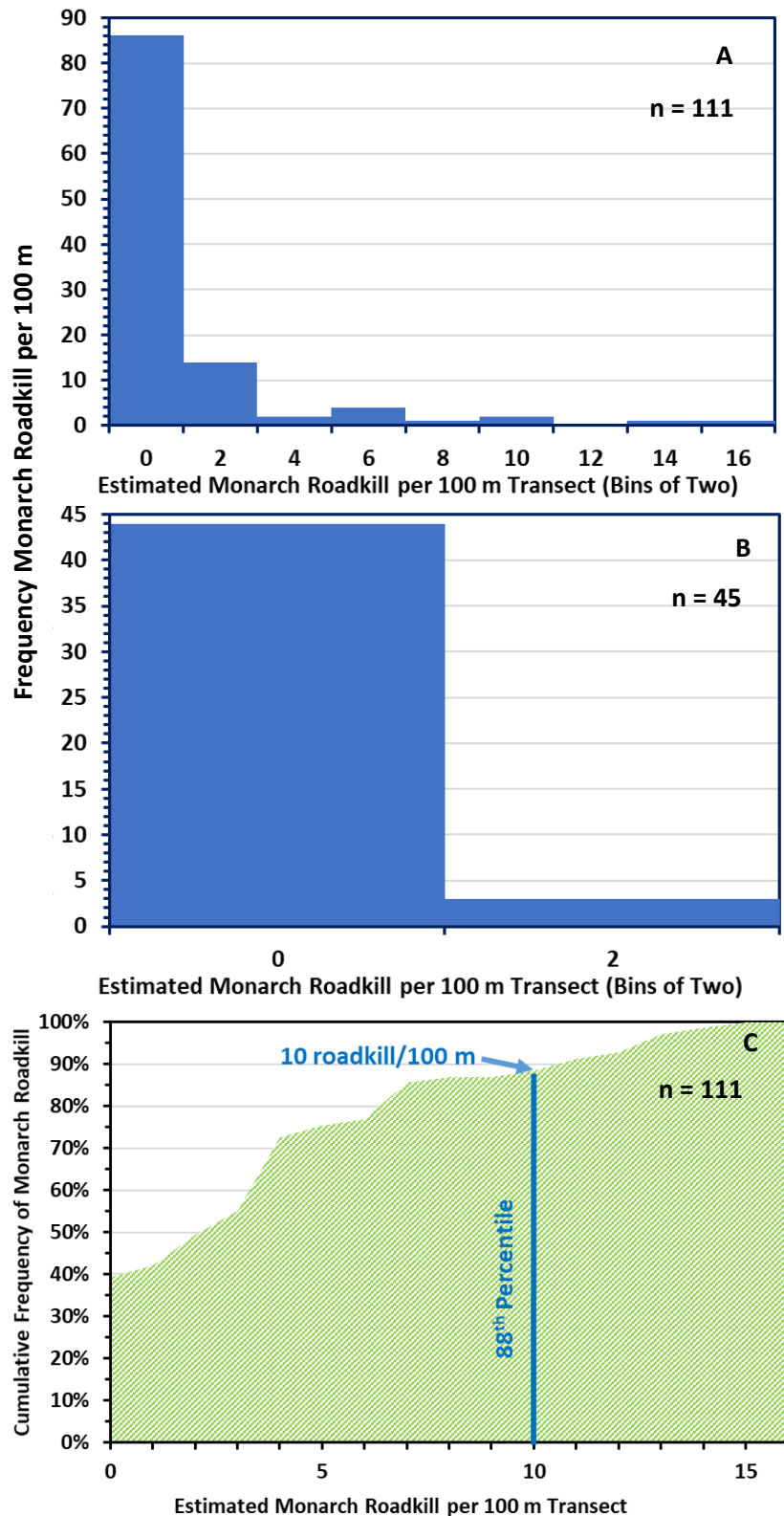
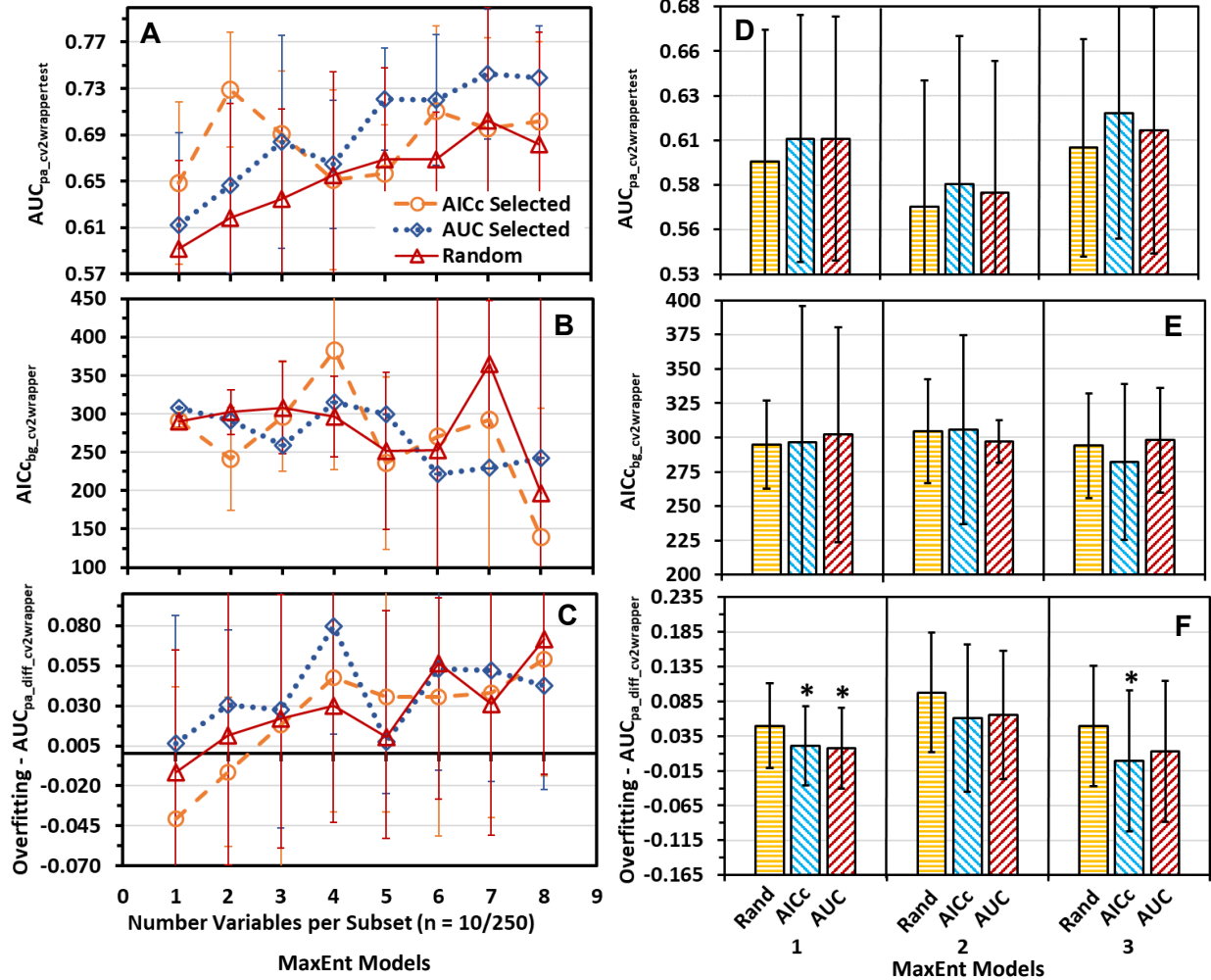


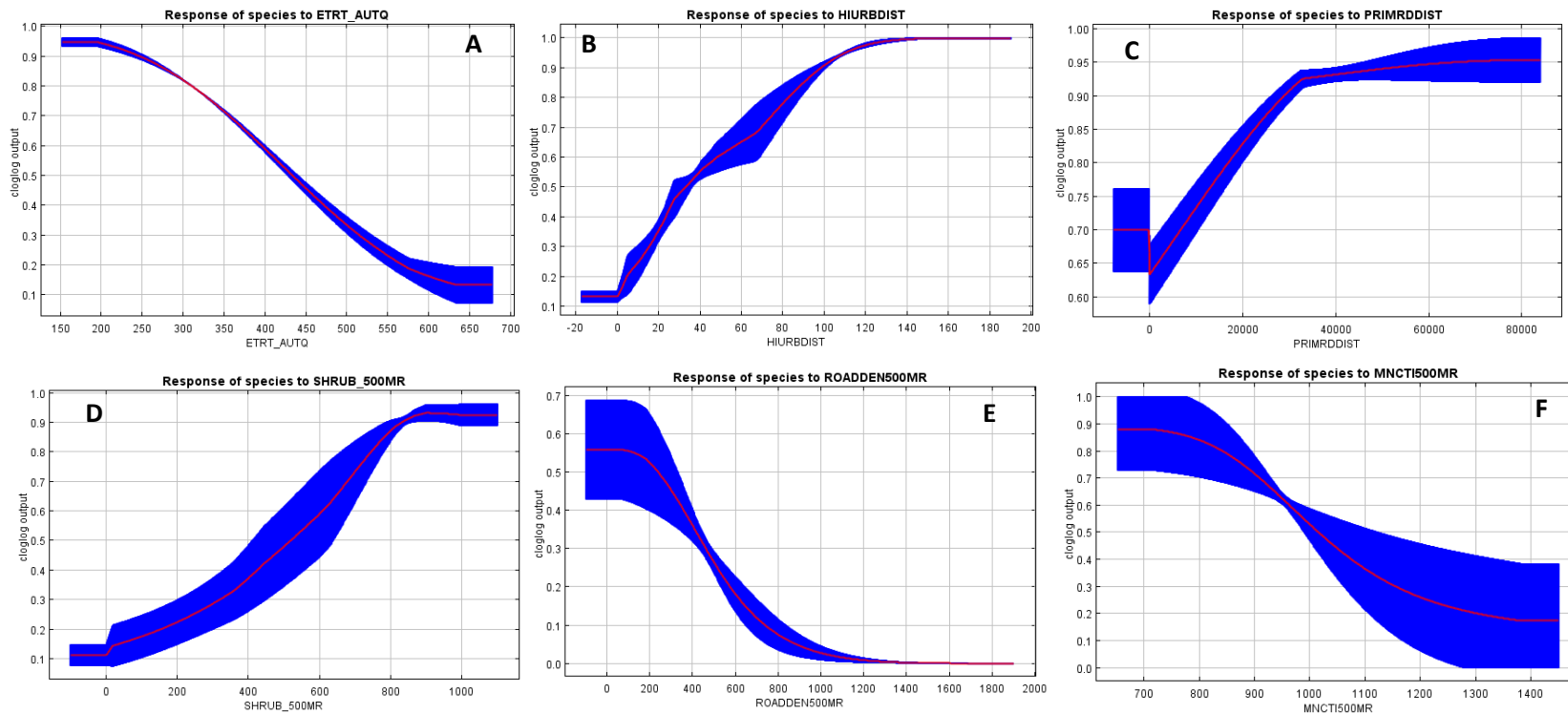
Figure 3. Spatial distribution of monarch roadkill per 100 m transect during the fall of 2019 within Texas monarch migratory funnels (from Tracy et al. 2020 Fig. 6C).



**Figure 4. Frequency histograms for monarch roadkill per 100m in the Central (A) and Coastal (B) funnels from spatially thinned data. Cumulative frequency of roadkill in Central Funnel (C) with 88<sup>th</sup> percentile for roadkill hotspots.**

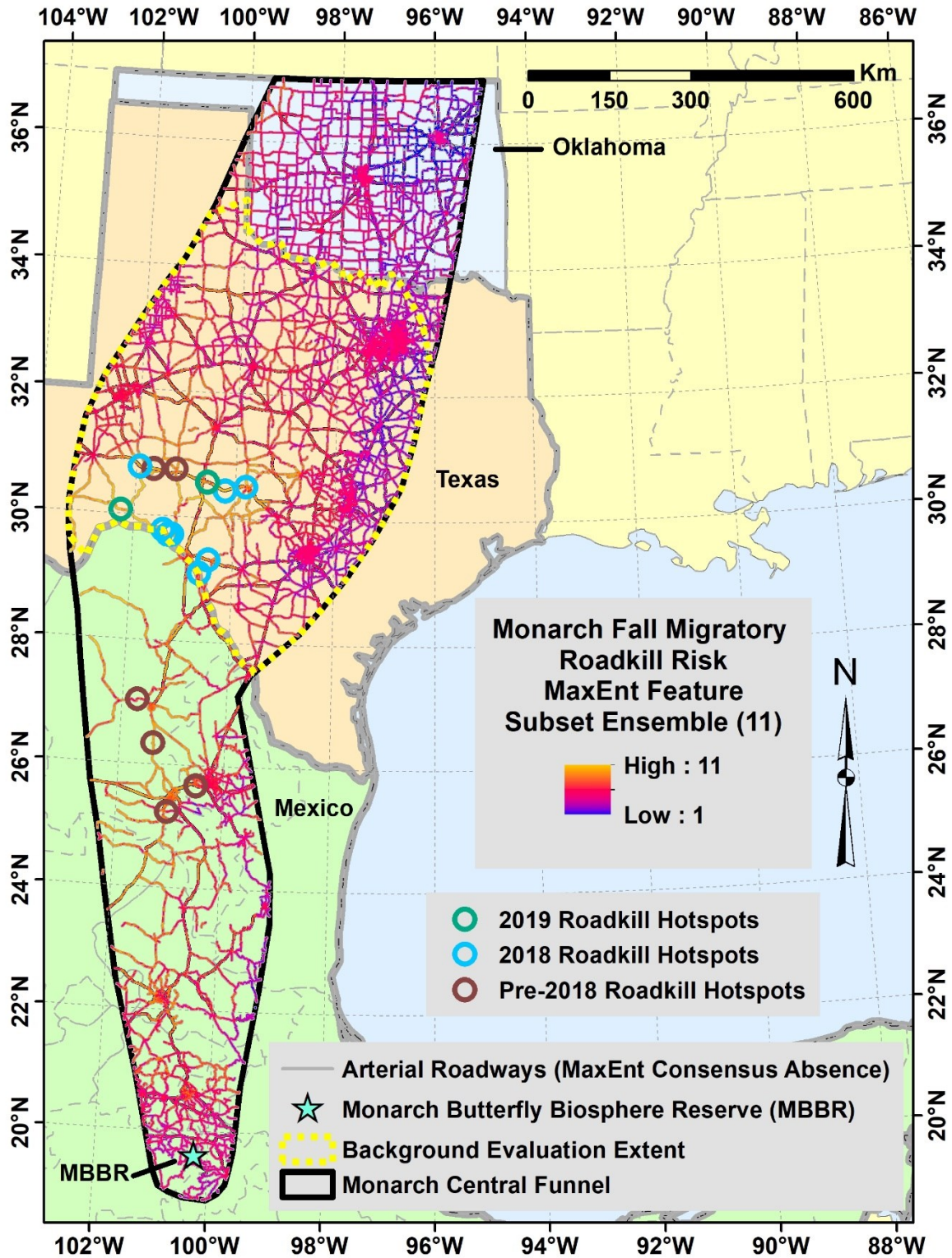


**Figure 5. Monarch roadkill Central Funnel MaxEnt model evaluation statistics (mean  $\pm$  SD) of  $AUC_{pa\_cv2wrappertest}$  (A,D),  $AICc_{bg\_final}$  (B,E), and  $AUC_{pa\_diff\_cv2wrapper}$  (overfitting; C,F) for models developed from (A-C) top ten variable subsets selected by  $AUC_{pa}$  or AICc using random subset feature selection (RSFSA) and ten random subsets out of 250 randomly generated subsets of various sizes derived from 95 variables; and (D-F) top 41 two-variable subsets out of 820 subsets per three training set replicates selected by  $AUC_{pa}$  or AICc using RSFSA and top 41 random generated two-variable subsets out of 820 subsets derived from 41 variables. Means for  $AUC_{pa}$  selected or AICc selected model statistics within a replicate with an asterisk are significantly more optimal (higher for  $AUC_{pa\_cv2wrappertest}$  and lower for  $AICc_{bg\_final}$  and  $AUC_{pa\_diff\_cv2wrapper}$ ) and means with an arrow significantly less optimal than mean of random selected models ( $P < 0.05$ ; Welch t test with Holm correction, preceded by significant Welch ANOVA test,  $P < 0.05$ ).**



**Figure 6. Monarch Central Funnel Roadkill MaxEnt model variable response curves for example variables from top ranked two-variable models: (A) *etr\_t\_autq*, (B) *hiurbdist*, (C) *primrddist*, (D) *shrub\_500mr*, (E) *roadden500mr*, (F) *mncti500mr* (see Table 1 for variable abbreviations). The curves represent logistic prediction changes as each environmental variable is varied while the other variables are kept at their average sample value.**





**Figure 7. Monarch roadkill in the Central Funnel represented by MaxEnt feature subset ensemble of eleven models developed from subsets of two of 41 variables by cross validated random subset feature selection for low AICc.**

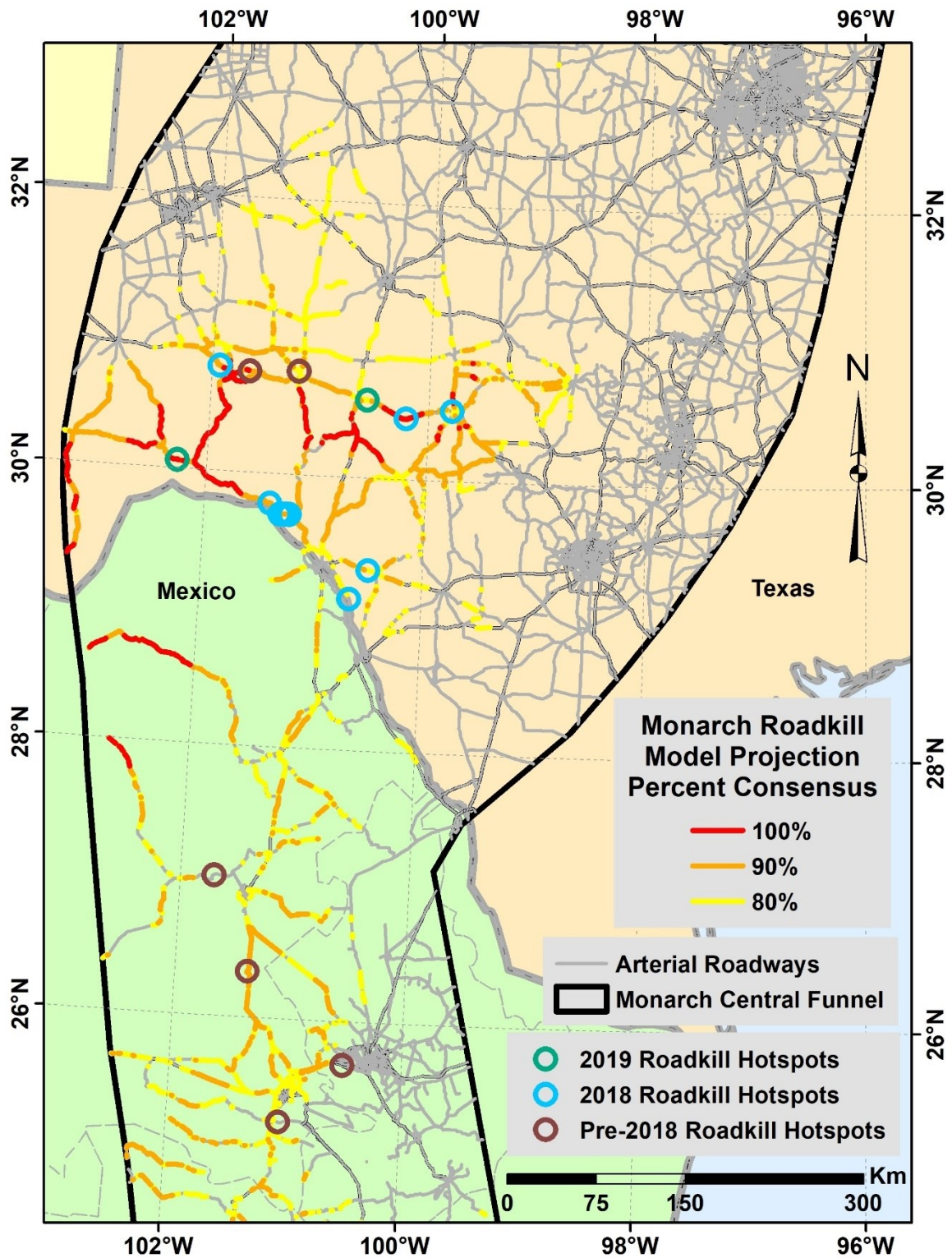


Figure 8. Monarch roadkill in the Central Funnel represented by 80%, 90% and 100% consensus of eleven feature selected MaxEnt models (Fig. 7).



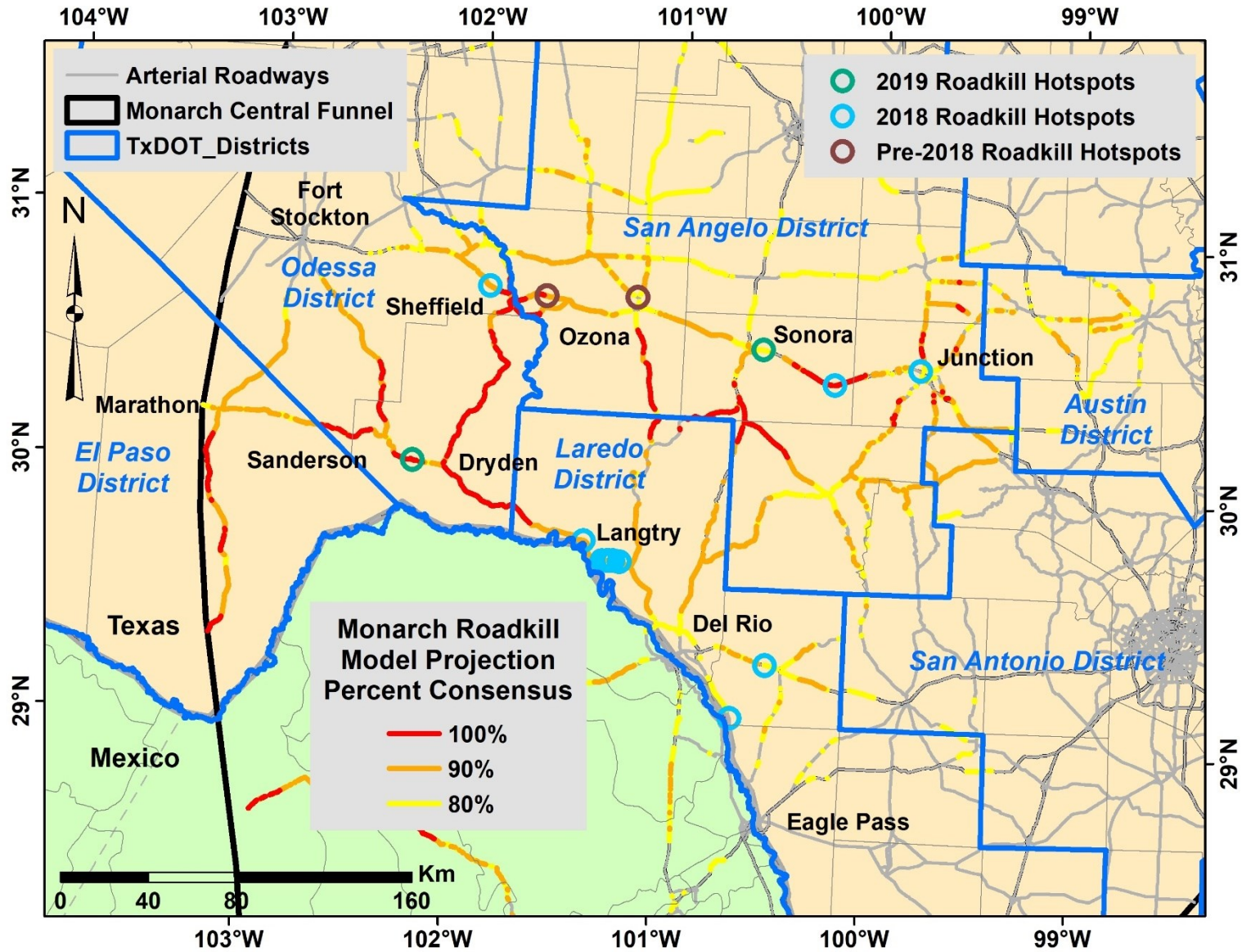


Figure 9. Monarch roadkill in the Central Funnel represented by 80%, 90% and 100% consensus of eleven feature selected MaxEnt models (Fig. 7) within TxDOT districts.

## References

- Bellamy, C., Scott, C., Altringham, J. 2013. Multiscale, presence-only habitat suitability models: fine-resolution maps for eight bat species. *Journal of Applied Ecology*, 50:892-901.
- Center for International Earth Science Information Network (CIESIN) - Columbia University. 2016. *Gridded Population of the World, Version 4 (GPWv4): Population Density*. NASA Socioeconomic Data and Applications Center (SEDAC), Palisades, New York, Available at: <http://sedac.ciesin.columbia.edu/data/set/gpw-v4-population-density/data-download>
- Chen, J., Chen, J., Liao, A., Cao, X., Chen, L., Chen, X., He, C., Han, G., Peng, S., Lu, M., Zhang, W. 2015. Global land cover mapping at 30 m resolution: A POK-based operational approach. *ISPRS Journal of Photogrammetry and Remote Sensing*, 103:7-27.
- Evans, J.S., Oakleaf, J., Cushman, S.A., Theobald, D. 2014. *An ArcGIS Toolbox for Surface Gradient and Geomorphometric Modeling, Version 2.0-0*. Available at: <https://www.arcgis.com/home/item.html?id=63ffcecf3b2a45bf99a84cdaedefaccf>
- Fick, S.E., Hijmans, R.J. 2017. WorldClim 2: new 1-km spatial resolution climate surfaces for global land areas. *International Journal of Climatology* 37:4302-4315.
- Geofabrik. 2017. OpenStreetMap Data Extracts. Available at: <http://download.geofabrik.de/>
- Hijmans, R.J., Cameron, S.E., Parra, J.L., Jones, P.G., Jarvis, A. 2005. A very high resolution interpolated climate surfaces for global land areas. *International Journal of Climatology*, 25:1965–1978
- Kantola T., Tracy, J.L., Baum, K.A., Quinn, M.A., Coulson, R.N. 2019. Spatial risk assessment of eastern monarch butterfly road mortality during autumn migration within the southern corridor. *Biological Conservation*, 231:150-160.
- Liu, C., White, M., Newell, G. 2013. Selecting thresholds for the prediction of species occurrence with presence-only data. *Journal of Biogeography*, 40:778–789. <https://doi.org/10.1111/jbi.12058>
- Monarch Watch. 2020. Monarch Population Status. *Monarch Watch Blog*, 13 March 2020. Available at: <https://monarchwatch.org/blog/2020/03/13/monarch-population-status-42/>



- Mora Alvarez, B.X., Carrera-Treviño, R., and Hobson, K.A. 2019. Mortality of monarch butterflies (*Danaus plexippus*) at two highway crossing “hotspots” during autumn migration in Northeast Mexico. *Frontiers in Ecology and Evolution*, 7: 273.
- NASA Jet Propulsion Laboratory (JPL). 2013. *NASA Shuttle Radar Topography Mission [SRTM] United States 1 Arc Second*. Version 3. 6oS, 69oW. NASA EOSDIS Land Processes DAAC, USGS Earth Resources Observation and Science (EROS) Center, Sioux Falls, South Dakota (<https://lpdaac.usgs.gov>). Available at: <http://dx.doi.org/10.5067/MEaSURES/SRTM/SRTMUS1.003>
- Thogmartin, W.E., Diffendorfer, J.E., López-Hoffman, L., Oberhauser, K., Pleasants, J., Semmens, B.X., Semmens, D., Taylor, O.R., Wiederholt, R. 2017. Density estimates of monarch butterflies overwintering in central Mexico. *PeerJ*, 5:e3221. <https://doi.org/10.7717/peerj.3221>
- Tracy, J.L., Kantola, T., Baum, K.A. and Coulson, R.N. 2019. Modeling fall migration pathways and spatially identifying potential migratory hazards for the eastern monarch butterfly. *Landscape Ecology*, 34(2): 443-458.
- Tracy J.L., and Coulson R.N. 2019. *Eastern Monarch Butterfly Fall Migratory Roadkill Distribution and Hotspot Regions within the Coastal and Central Migratory Funnels of Texas*. Texas A&M Department of Entomology/Texas Transportation Institute Project Final Report. TxDOT Environmental Affairs Division, Austin, Texas. 32 pp. Available at: [https://www.dropbox.com/s/an9wuzkyr54xdb0/TTI\\_TAMU%20Texas%20Monarch%20Roadkill%20Fall%202018%20Report.docx?dl=0](https://www.dropbox.com/s/an9wuzkyr54xdb0/TTI_TAMU%20Texas%20Monarch%20Roadkill%20Fall%202018%20Report.docx?dl=0)
- Warren, D.L., Seifert, S.N. 2011. Ecological niche modeling in MaxEnt: the importance of model complexity and the performance of model selection criteria. *Ecological Applications* 21:335–342. <https://doi.org/10.1890/10-1171.1>
- WorldClim. 2017. *WorldClim Version 1*. Available at: <http://www.worldclim.com/current>
- WorldClim2. 2017. *WorldClim Version 2*. Available at: <https://worldclim.org/data/worldclim21.html>

## Appendix

**Table A1. Monarch Central Funnel roadkill for 2019 feature-selected MaxEnt model environmental variables.<sup>a</sup>**

Model Number with Two Environmental Variables (Permutation Importance)					
Model 1	Model 2	Model 3	Model 4	Model 5	Model 6
<i>elev</i> (100)	<i>cult_500mr</i> (100)	<i>winsp_autq</i> (61.4)	<i>cult_500mr</i> (65.3)	<i>hiurbdist</i> (96.6)	<i>slope</i> (0)
<i>primrddist</i> (0)	<i>forest_500mr</i> (0)	<i>diss90mr</i> (38.6)	<i>roadden500mr</i> (34.7)	<i>diss90mr</i> (3.4)	<i>scai</i> (0)
Model 7	Model 8	Model 9	Model 10	Model 11	Model 12
<i>mncti500mr</i> (94.3)	<i>mnpopden9kr</i> (81.6)	<i>forest_500mr</i> (100)	<i>seadist</i> (100)	<i>shrub_500mr</i> (100)	<i>etr_t_autq</i> (100)
<i>forest_500mr</i> (5.7)	<i>diss90mr</i> (18.4)	<i>aspect</i> (0)	<i>tpi30mr</i> (0)	<i>mnfloacc500mr</i> (0)	<i>tpi30mr</i> (0)

<sup>a</sup>For variable abbreviations, see Table 1. Variables with zero permutation importance not used in model.

## CHAPTER 3. FALL 2016 TO 2019 MONARCH ROADKILL MODELS AND ROADKILL HOTSPOT DISTRIBUTIONS

### Summary

The first combined 2016-2019 four-year monarch roadkill MaxEnt models were developed for the Texas Central Funnel. The models clearly indicate higher monarch roadkill in the southwest Texas portion of the Central Funnel, aligning well with observed roadkill hotspots. Monarch roadkill hotspots were categorized by density using 2016 data, and hotspots were mapped using kernel density estimate (KDE) intensities for the Central and Coastal Funnel. Monarch roadkill super-hotspots in 2016 were all associated with creeks and draws along or near IH-10 from Sonora to Sheffield, as were some hotspots on US-90 west of Sanderson. The five known live monarch roadkill hotspot observations occurred from 12-23 October, which generally aligns with peak monarch weekly migration mapped using KDE intensity. Potential direct mitigation for monarch roadkill should include identified creeks and draws associated with past hotspots and be implemented during the period of 12-25 October.

### Methods

#### *Monarch Roadkill Observations and Extrapolations*

Monarch roadkill observations in the Texas Central Funnel from 2016-2019 were made following the same protocol as described in previous studies involving monitoring of 100m x 1m transects spaced about every 20-50 km (Fig. 1) (Kantola et al. 2019a, Tracy and Coulson 2019, Tracy et al. 2020b). Estimations of fall monarch roadkill per 100 m for both sides of the roadway were made using transect data from 2016, 2017 (Kantola et al. 2019a), 2018 (Tracy and Coulson 2018), and 2019 (Tracy et al. 2020a).

#### *Environmental Variables*

Forty-two environmental variables at 30.8 m resolution were developed for modeling roadkill in the Central Funnel (Table 1), which is an expanded combination of the variables employed in previous studies (Kantola et al. 2019a, Tracy and Coulson 2019, Tracy et al. 2020b). The variables include six road indices, four human population indices, 20 topographic indices, eight land cover indices, and four climatic indices (for additional details, see Kantola et al. 2019, Tracy and Coulson 2019, Part III Chapter 2)

#### *MaxEnt Roadkill Niche Models and Feature Selection*

Roadkill presence data were independently randomly spatially thinned to 2 km to reduce spatial autocorrelation. In contrast to previously discussed studies on Texas

monarch roadkill that employed the limited available absence data from roadkill transects, artificially generated pseudoabsence and background data were used, which is more standard procedure for MaxEnt modeling. About 10,000 pseudoabsence points were generated for model evaluation within the background evaluation extent, consisting of the Texas Central Funnel. We followed the standard practice of utilizing as absence points our generated pseudoabsence points buffered from the presence points by 2 km (e.g., Barbet-Massin et al. 2012). These pseudoabsence points were used in the calculation of the pseudoabsence (psa) version of the true skill statistic ( $TSS_{psa}$ ) and area under the curve statistic ( $AUC_{psa}$ ) using random cross validation and the R PresenceAbsence package (Freeman and Moisen 2008).

The final MaxEnt models chosen by feature selection were calibrated to binary presence/absence format using a threshold of maximum  $TSS_{pa}$  (Liu et al. 2013) and combined using frequency consensus to form a feature subset ensemble (for further details, see Tracy and Coulson 2019). Roadkill models developed for the Texas Central Funnel were then projected across the entire Central Funnel, including portions of Oklahoma and Mexico (Fig. 1). We utilized a modified version of the random subset feature selection algorithm (RSFSA-CV; Tracy et al. 2018) to select a high performing ensemble of MaxEnt roadkill models using different subsets of the 42 environmental variables or predictors (for additional details see Tracy et al. 2018, Tracy and Coulson 2019, Part III Chapter 2).

### *Monarch Roadkill Hotspot Distribution and Hotspot Intensity*

Monarch roadkill transect data from fall 2016 has the largest incidence and variation in hotspot intensity for the Texas Central Funnel. Consequently, the 2016 roadkill presence and absence data were used to define roadkill hotspot intensity classes based on cumulative frequency of roadkill intensities (c.f., Ramp et al. 2005, Tracy and Coulson 2019). An intensity surface of fall monarch roadkill for 2016-2019 Texas Central Funnel was developed at 30.8 m resolution using kernel density tool in ArcGIS (ESRI Inc., Redlands, California) with roadkill count per transect as population weighting (points as values, expected count output, geodesic method). The same procedure was applied for developing hotspot roadkill intensity from kernel density estimation (KDE) for 2018 in the Texas Coastal Funnel. The lower intensity portions of the KDE intensity surface were omitted from the display in order to highlight roadkill hotspots. Roadkill hotspot locations were also mapped by year and intensity.

### *Hotspot Seasonal Occurrence in Texas*

Dates and locations of live roadkill hotspot observations were documented and mapped. The weekly distribution of fall migratory adults (including roosts) from Journey North (2017), as separated from premigrant adults by Kantola et al. (2019b), were used to develop migratory intensity surfaces for Texas. The KDE surface was developed using



methods described in Tracy et al. (2019), with observation points weighted higher that occurred within lower human population density areas in order to help account for observer bias. The surfaces were restricted to omit lower density areas and overlaid with roadkill hotspot occurrences for the Central Funnel in order to examine the weekly distribution of migratory monarchs in relation to areas of monarch roadkill hotspots.

## Results and Discussion

### *MaxEnt Roadkill Niche Models and Feature Selection*

A total of 116 monarch roadkill presence points thinned by 2 km were available from 2016-2019 for modeling of roadkill distribution (146 unthinned). This is much greater than the only 21 and 25 presence points available for 2017 and 2019, respectively, which is close to the minimum needed for MaxEnt modeling (Part III Chapter 2).

Two of 42 variables appeared to provide Central Funnel MaxEnt roadkill models with the highest accuracy ( $AUC_{psa}$ ), lowest complexity ( $AIC_{c_{bg}}$ ), and lowest overfitting ( $AUC_{psa\_diff}$ ) (Fig. 2A-C). Three RSFSA-CV feature selection replicates with thousands of six-variable MaxEnt models showed improvement in all three measures only when using  $AUC_{psa}$ , rather than  $AIC_{c_{bg}}$ , as a model selection criterion (Fig. 2D-F). Consequently,  $AUC_{psa}$  was selected as the final model ranking criterion.

Accuracy performance of the 12 selected MaxEnt Central Funnel roadkill models was high, with an average accuracy with respect to the pseudoabsence points,  $AUC_{psa}$ , of  $0.91 \pm 0.01$  ( $\bar{X} \pm SD$ ). This is much higher than the average  $AUC_{pa}$  values found in previous Central Funnel roadkill MaxEnt models ranging from 0.61 to 0.64 (Kantola et al. 2019a, Tracy and Coulson 2018, Part III Chapter 2). The average accuracy with respect to background points,  $AUC_{bgp}$  (MaxEnt default AUC),  $0.87 \pm 0.01$ , was similar the value of 0.86 found in two of the previous studies (Kantola et al. 2019, Tracy and Coulson 2019).

Indices from all five categories were important in the monarch roadkill niche modelling (Table 1). Two of each of the five index categories appeared among the ten highly ranked variables in the feature selected MaxEnt models (Table 2). The highest ranked variable was the topographic index of distance to the sea (*seadist*), with more roadkill projected at intermediate distances (Fig. 3A). *Seadist* was probably reflective of the distance to the sea from the area of most intense roadkill in southwest Texas. The second and third ranked variables were the climatic indices of autumn evapotranspiration ratio, *etr\_autq*, and annual precipitation, *prec\_ann*. Both of these indices indicated fall monarch roadkill was associated with more arid areas (Fig. 3B), as was found by Kantola et al. (2019a). Latitude was also highly ranked, which probably also reflected the localized distribution of roadkill in the southwestern Texas region (Fig. 3C). High density of shrubland (*shrub\_500mr*), common in southwest Texas, was also indicative of roadkill (Fig. 3D). Lower human population density (*mnpopden9kr* and

*mnpopden3kr*) was also important in models of Kantola et al. (2019), and reflects the sparsely populated southwest Texas areas of highest roadkill prediction. Roadkill was more associated with proximity to motorways (*motorwaydist*) than proximity to secondary roads (*seconddist*) (Fig. 3F).

The consensus of the top 12 selected MaxEnt models projected the highest monarch roadkill for the southwest portion of the Texas Central Funnel, with high roadkill also projected south into Mexico, where larger roadkill hotspots have been found (Mora Alvarez et al. 2019) (Fig. 4). This arid, sparsely populated, southwestern region was also projected to have the highest roadkill in the previous studies (Kantola et al. 2019, Tracy and Coulson 2019, Part III Chapter 2).

### *Monarch Roadkill Hotspot Distribution and Hotspot Intensity*

Roadkill in 2016 ranged from zero to 179 per 100m transect. The lower limit for secondary roadkill hotspots was defined at the 85<sup>th</sup> percentile of cumulative frequency of monarch roadkill, which represents 7 roadkill per 100m. The starting level of primary roadkill hotspots was defined at the 90<sup>th</sup> percentile, representing 29 roadkill per 100m. Roadkill super-hotspots were defined at densities reaching the 95<sup>th</sup> percentile, representing 109 roadkill per 100m (Fig. 5).

Monarch roadkill KDE intensity surfaces in the Texas Central Funnel for the 10-100% level (upper 90%, omitting lowest 10%) corresponded well with the highest MaxEnt projected roadkill for 2016-2019 (Figs. 6-7). Monarch roadkill KDE intensity in the Coastal Funnel of 20-100% (upper 80%) corresponded well with monarch roadkill hotspots and 80-100% MaxEnt projections of monarch roadkill (from Tracy and Coulson 2019) (Fig. 8).

The yearly distribution of monarch roadkill hotspots for 2016-2019 was variable, but always restricted to the Junction-Sheffield-Eagle Pass Hotspot Region (c.f., Tracy and Coulson 2019) (Fig. 9). Roadkill hotspots occurred for all four years only on the stretch of IH-10 from Junction to just west of Sonora. Most roadkill hotspots were restricted to IH-10 in 2016 and 2017, US-90 and US-277 in 2018, and US-90 in 2019. Six monarch roadkill super-hotspots occurred in 2016, mostly west of Ozona on IH-10 (Fig. 10). All of the roadkill super-hotspots occurred in proximity to creeks or draws (Figs. 11-14), which are often followed by monarchs for migration, especially in desert areas (Chip Taylor, Monarch Watch, personal communication). Creeks and draws associated with 2016 super-hotspots include Howards Creek and Pikes Peak Draw along IH-10 west of Ozona (Figs. 11-13), Wildcat Draw along SH-137 north of Ozona (Fig. 14; also a possible hotspot in 2009), and Granger Draw along IH-10 west of Sonora (Fig. 15). Further analysis is needed of the potential correlation of roadkill density and proximity to creeks or draws for 2016 and other years. Two hotspots along US-90 east of Sanderson (Fig. 16) are associated with roosting in trees along areas where Sanderson Canyon (a draw)

crosses the highway (Table 3). Planned fall 2020 roadkill observations should include these hotspot areas and some intervening areas for comparison. One of the 2016 hotspot locations at the IH-10 Sonora Safety Rest Stop was also associated with roosting (Fig. 16; Table 3). This makes for a total of three of six live observations of monarch roadkill being associated with roosting, but none of these included the six super-hotspot locations previously discussed. The 2016 super-hotspot locations near creeks and draws along and near IH-10 may represent the best specific potential locations for direct mitigation of monarch roadkill. The two Sanderson Canyon hotspots could be included for US-90.

### *Hotspot Seasonal Occurrence in Texas*

All five known live observations of monarch roadkill hotspots occurred during the second and third weeks of October (weeks of year 42 and 43) (Table 3; Fig. 16). Four of the five observations occurred from 12-17 October (week 42), and one occurred 23 October (week 43). The temporal distribution of migratory monarchs in relation to roadkill hotspot areas was examined using weekly distribution data from Journey North for 1997 to 2017 (Journey North 2020) that was filtered to separate migrants from premigrants by Kantola et al. (2019b). The 25-100% KDE intensity (upper 75%) surface for the migrants was used to highlight fall weekly peak migratory monarch locations (Figs. 17-18). The locations of the five live monarch roadkill observations in the Texas Central Funnel generally coincide with the locations for peak migratory monarch intensities around week 42 (12-18 October) (Fig. 18). The migration in the Coastal Funnel is generally about two weeks later (Kantola et al. 2019b), and a similar analysis of weekly migration progression in hotspots is planned. Potential direct roadkill mitigation in the Central Funnel should focus on the two-week period from 12-25 October.

### *Conclusion*

Texas Central Funnel monarch roadkill models developed from combined 2016-2019 data were highly accurate and clearly projected highest roadkill for the Southwest Texas portion of the Central Funnel. Monarch roadkill hotspots for Texas were categorized into secondary, primary, and super-hotspots. The upper 80 and 90% KDE surface of roadkill intensity corresponded well with the locations of roadkill hotspots in the Coastal and Central Funnels respectively. The locations of roadkill hotspots in the Texas Central Funnel varied from 2016-2019, but generally occurred over the same region from Junction to Sheffield to Eagle Pass. Roadkill super-hotspots in 2016, and some other 2017 and 2019 hotspots, were all in proximity to creek and draw features that monarchs may be following for migratory pathways. All five known live monarch roadkill observations in the Texas Central Funnel occurred from 12-23 October. Potential direct mitigation for monarch roadkill in the Texas Central Funnel should focus on previously identified super-hotspot and hotspot areas in proximity to creeks and draws, and be timed to occur during the period of 12-25 October.

## Tables

**Table 1. Forty-two environmental predictor indices (30.8 m resolution) evaluated for developing monarch roadkill models.**

Variable Index	Abbreviation <sup>a</sup>	Source
<b>Six Road Indices</b> (based on four Open Street Map major road types of motorways, trunks, primary roads, and secondary roads)		
Road density, km road in 500 m circular radius (km/0.78 km <sup>2</sup> ) <sup>b</sup>	<i>roadden500mr*</i>	Derived from OpenStreetMap (Geofabrik, 2017)
Road density, km road in 3 km circular radius (km/28 km <sup>2</sup> ) <sup>b</sup>	<i>roadden3kr</i>	"
Distance to motorways (m)	<i>motorwaydist*</i>	"
Distance to trunks (m)	<i>trunkdist*</i>	"
Distance to primary roads (m)	<i>primarydist*</i>	"
Distance to secondary roads (m)	<i>seconddist</i>	"
<b>Four Human Population Density Indices</b>		
Human population density per km <sup>2</sup>	<i>popden*</i>	CIESIN (2016)
Human population density per km <sup>2</sup> in 3 km circular radius (population/28 km <sup>2</sup> ) <sup>b</sup>	<i>mnpopden3kr*</i>	Derived from CIESIN (2016)
Human population density per km <sup>2</sup> in 9 km circular radius (population/254.5 km <sup>2</sup> ) <sup>b</sup>	<i>mnpopden9kr*</i>	"
Distance to urban areas ≥ 300 humans per km (km)	<i>hiurbdist*</i>	"
<b>Twenty Topographic Indices</b>		
Aspect	<i>aspect*</i>	Derived from 1 arc second resolution SRTM elevation (NASA JPL 2013)
Compound Topographic Index (CTI) <sup>c</sup>	<i>cti</i>	"
Curvature (standard combination of profile and planform curvature)	<i>curv</i>	"
Dissection, 90 m circular radius <sup>c</sup>	<i>diss90mr*</i>	"
Elevation (m)	<i>elev*</i>	NASA JPL (2013)
Elevation Relief Ratio, 30 m circular radius <sup>c</sup>	<i>err30mr*</i>	Derived from 1 arc second resolution



**Table 1. Forty-two environmental predictor indices (30.8 m resolution) evaluated for developing monarch roadkill models.**

Variable Index	Abbreviation <sup>a</sup>	Source
		SRTM elevation (NASA JPL 2013)
Latitude (decimal degrees × 10,000)	<i>latitude*</i>	
Mean CTI, 500 m circular radius <sup>b</sup>	<i>mncti500mr*</i>	"
Mean CTI, 3 km circular radius <sup>b</sup>	<i>mncti3kr*</i>	"
Mean Flow Accumulation, 500 m circular radius <sup>d</sup>	<i>mnfloacc500mr</i>	"
Mean Flow Accumulation, 3 km circular radius <sup>d</sup>	<i>mnfloacc3kmr</i>	"
Mean Slope, 50 m circular radius <sup>b</sup>	<i>mnslope50mr*</i>	"
Mean Slope, 150 m circular radius <sup>b</sup>	<i>mnslope150mr*</i>	"
Sea Distance (m)	<i>seadist*</i>	"
Site Exposure Index (SEI) <sup>c</sup>	<i>sei*</i>	"
Slope	<i>slope</i>	"
Slope Cosine Aspect Index (SCAI) <sup>c</sup>	<i>scai</i>	"
Topographic Position Index (TPI), 30 m circular radius <sup>b,c</sup>	<i>tpi30mr</i>	"
TPI, 90 m circular radius <sup>b,c</sup>	<i>tpi90mr</i>	"
TPI, 300 m circular radius <sup>b,c</sup>	<i>tpi300mr</i>	"
<b>Eight 2010 Globeland30 Land Cover Indices (percent cover in 500 m radius window × 1000; area/0.78km<sup>2</sup>)</b>		
		Globeland30 (Chen et al. 2015)
Artificial surfaces	<i>artsur_500mr*</i>	
Barren lands	<i>bare_500mr</i>	"
Cultivated land	<i>cult_500m*</i>	"
Forests	<i>forest_500mr</i>	"
Grasslands	<i>grslnd_500mr*</i>	"
Shrublands	<i>shrub_500mr*</i>	"

**Table 1. Forty-two environmental predictor indices (30.8 m resolution) evaluated for developing monarch roadkill models.**

Variable Index	Abbreviation <sup>a</sup>	Source
Water bodies	<i>water_500mr</i>	"
Wetland	<i>wetlnd_500mr*</i>	"
<b>Four Climatic Indices<sup>e</sup></b>		
Autumn quarterly mean monthly maximum temperature (°Celsius)	<i>tmax_autq</i>	for 1960–1990 derived from WorldClim (2017) of Hijmans et al. (2005)
Annual mean monthly rainfall (mm)	<i>prec_ann*</i>	"
Autumn quarterly mean monthly actual evapotranspiration/potential evapotranspiration × 1000	<i>etr_t_autq</i>	"
Autumn mean quarterly wind speed (m/second)	<i>wensp_autq*</i>	for 1970–2000 derived from WorldClim2 (2017) of Fick and Hijmans (2017)

<sup>a</sup>Asterisks indicate variables utilized in feature selected MaxEnt monarch roadkill niche models.

<sup>b</sup>Variables of different scales (radii) can perform differently in niche models (e.g., Bellamy and Altringham 2013).

<sup>c</sup>Calculated using Geomorphometry and Gradient Metrics Toolbox for ArcGIS (Evans et al. 2014).

<sup>d</sup>Flow accumulation for a grid cell is defined by the number of upslope cells from which water can be accumulated, as calculated by ArcGIS software Flow accumulation tool.

<sup>e</sup>Autumn quarter includes October, November, and December.

**Table 2. Monarch Central Funnel 2016-2019 roadkill MaxEnt model 10 top ranked variables across variable correlation groups from three replicates of 250 out of 3,000 models selected by random subset feature selection.<sup>a</sup>**

Variable (n)	Correlation Group	Joint Ranking <sup>b</sup>	Mean Permutation Importance	Mean Frequency in Models
<i>seadist</i> (3)	1	1.7 ± 0.6	35.5 ± 2.7	144.3 ± 51.5
<i>etr_t_autq</i> (3)	2	3.3 ± 3.2	54.2 ± 3.3	71.0 ± 45.5
<i>prec_ann</i> (3)	2	3.7 ± 1.2	53.5 ± 2.6	62.0 ± 22.3
<i>latitude</i> (3)	3	3.7 ± 0.6	35.9 ± 1.9	79.0 ± 12.2
<i>shrub_500mr</i> (3)	4	6.7 ± 1.2	20.0 ± 7.5	53.3 ± 15.1
<i>mnpopden9kr</i> (3)	5	8.0 ± 2.0	28.1 ± 2.0	27.3 ± 4.2
<i>mnpopden3kr</i> (3)	5	8.3 ± 1.2	26.3 ± 3.9	29.3 ± 3.1
<i>seconddist</i> (3)	6	9.7 ± 4.2	13.9 ± 2.0	46.3 ± 11.6
<i>motorwaydist</i> (3)	7	11.3 ± 3.1	10.5 ± 3.4	55.7 ± 11.0
<i>artsur_500mr</i> (3)	8	13.0 ± 3.0	14.6 ± 2.9	36.7 ± 27.1

<sup>a</sup>For variable abbreviations see Table 1. n = number out of three feature selection replicates in which variable appeared. All variables were used in our randomly selected 12 top models (see Table A1).

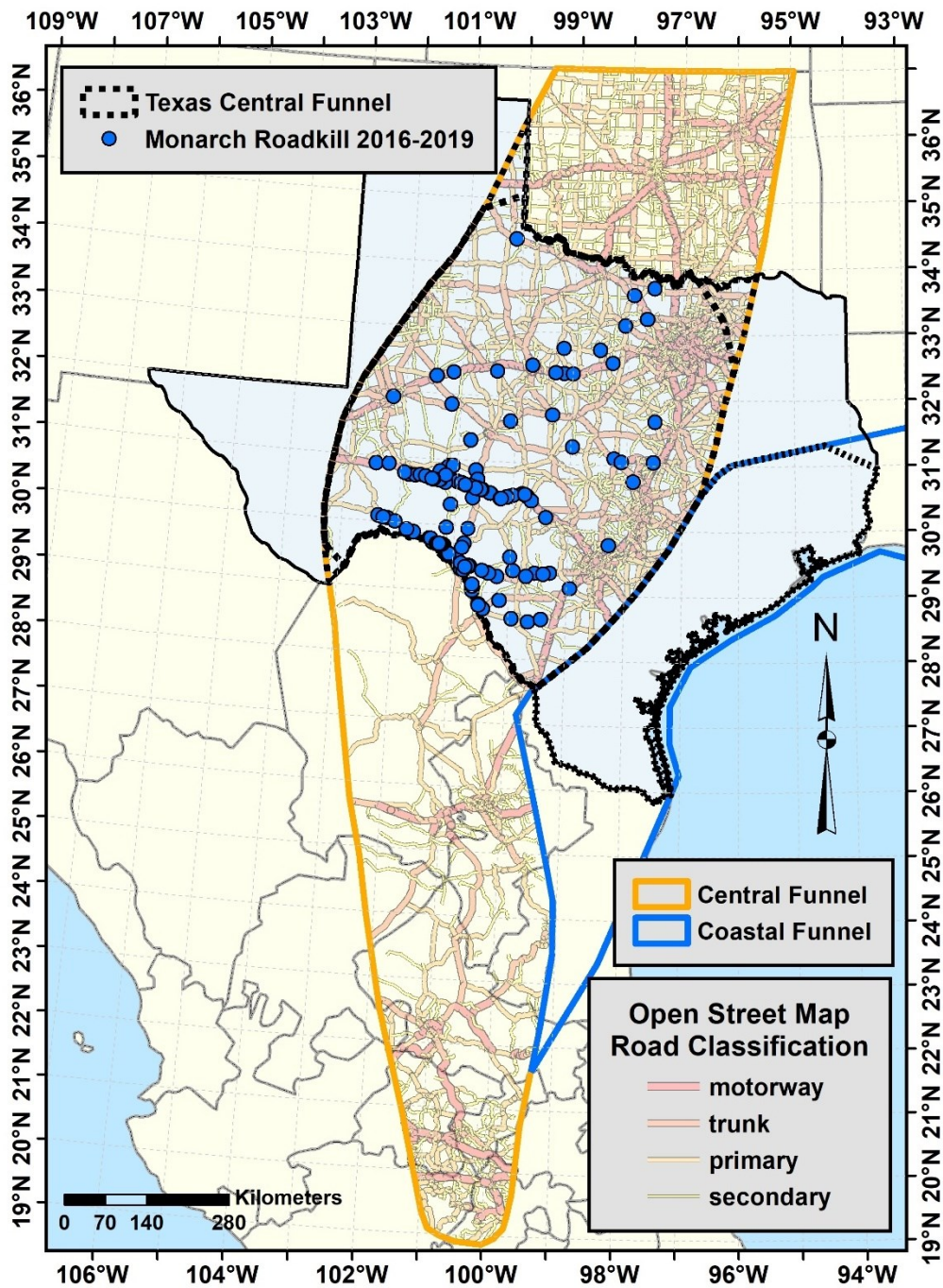
<sup>b</sup>Variable joint ranking by combination of permutation importance and frequency in all RSFSA\_CV selected models (c.f., Tracy et al. 2018, Part III Chapter 2).

**Table 3. Live observations of monarch roadkill hotspots in the Texas Central Funnel.**

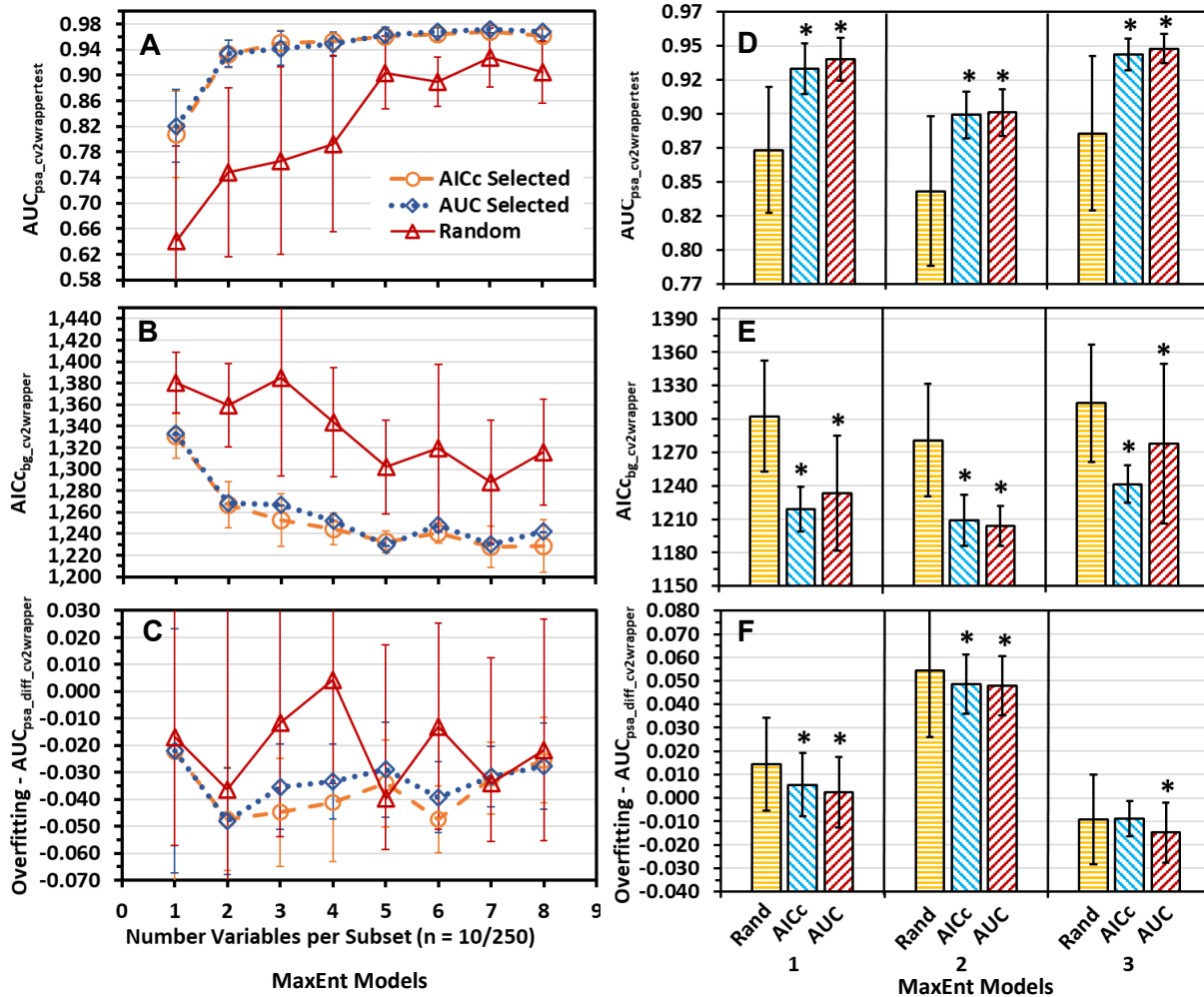
Location	Latitude	Longitude	Date	Comments	Source
SH-137 Northwest Ozona (location approximate)	30.75386	-101.20320	12 Oct 2009	"numerous roadkills"	Journey North (2020) Record ID 1255440283
IH-10 16 km East of Pecos River (E Sheffield)	30.73860	-101.65393	23 Oct 2015	at least 200 roadkill roosting in trees under bridge,	Dr. Salvador Vitanaza- Journey North (2020) Record ID 1445647488
US-90 at first Sanderson Canyon Bridge west of Sanderson	30.10479	-102.36430	14 Oct 2016	getting killed on highway	Journey North (2020) Record ID 1476920904 Journey North (2020) Record ID 1476796233;
IH-10 at Sonora Safety Rest Stop	30.61606	-100.74519	17 Oct 2016	roosting in live oak at rest stop; "getting slaughtered on the highway"	John Maresh, pers. comm., TxDOT (see Kantola et al. 2019a)
US-90 at Sanderson Canyon crossing 5 km West of Sanderson	30.06083	-102.26536	13 Oct 2019	roosting in mesquite tree and killed on roadway; with photos	Sara Dykman (see Part II Chapter 2)



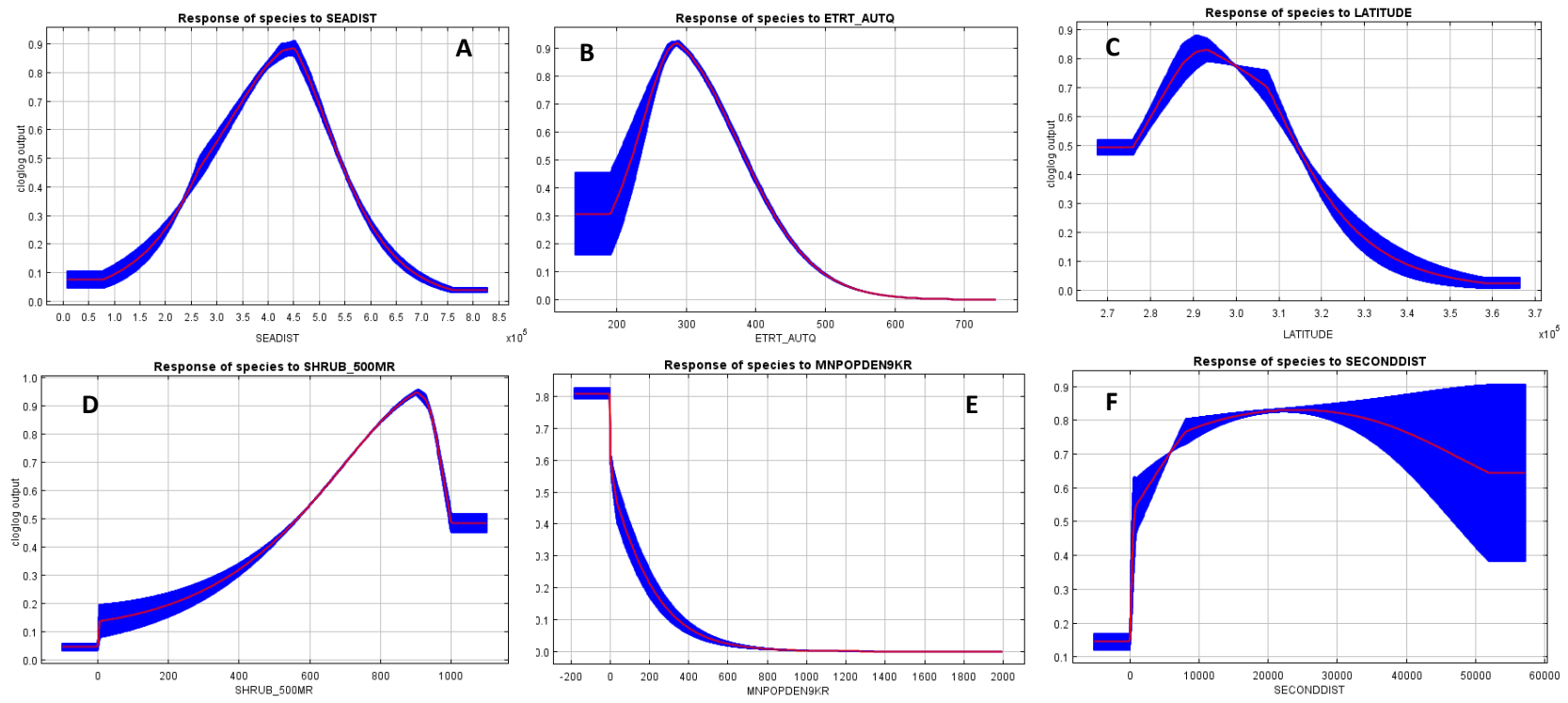
## Figures



**Figure 1. Distribution of fall 2016-2019 100m x 1m roadkill transects over Texas roadways within the monarch migratory Texas Central Funnel.**



**Figure 2. Monarch roadkill Central Funnel 2016-2019 presence only MaxEnt model evaluation statistics (mean ± SD) of  $AUC_{psa\_cv2wrappertest}$  (A,D),  $AICc_{bg\_final}$  (B,E), and  $AUC_{psa\_diff\_cv2wrappertest}$  (overfitting; C,F) for models developed from (A-C) top ten variable subsets selected by  $AUC_{psa}$  or  $AICc$  using random subset feature selection (RSFSA) and ten random subsets out of 250 randomly generated subsets of various sizes derived from 42 variables; and (D-F) top 250 two-variable subsets out of 3,000 subsets per three training set replicates selected by  $AUC_{psa}$  or  $AICc$  using RSFSA and top 250 random generated two-variable subsets out of 3,000 subsets derived from 42 variables. Means for  $AUC_{psa}$  selected or  $AICc$  selected model statistics within a replicate with an asterisk are significantly more optimal (higher for  $AUC_{psa\_cv2wrappertest}$  and lower for  $AICc_{bg\_final}$  and  $AUC_{psa\_diff\_cv2wrappertest}$ ) than mean of random selected models ( $P < 0.05$ ; Welch t test with Holm correction, preceded by significant Welch ANOVA test,  $P < 0.05$ ).**



**Figure 3. Monarch Central Funnel 2016-2019 roadkill MaxEnt model variable response curves for example top ranked variables (Table 2) from top ranked six-variable models: (A) *seadist*, (B) *etr\_t\_autq*, (C) *latitude*, (D) *shrub\_500mr*, (E) *mnpopden9kr*, (F) *seconddist* (see Table 1 for variable abbreviations). The curves represent logistic prediction changes as each environmental variable is varied while the other variables are kept at their average sample value.**



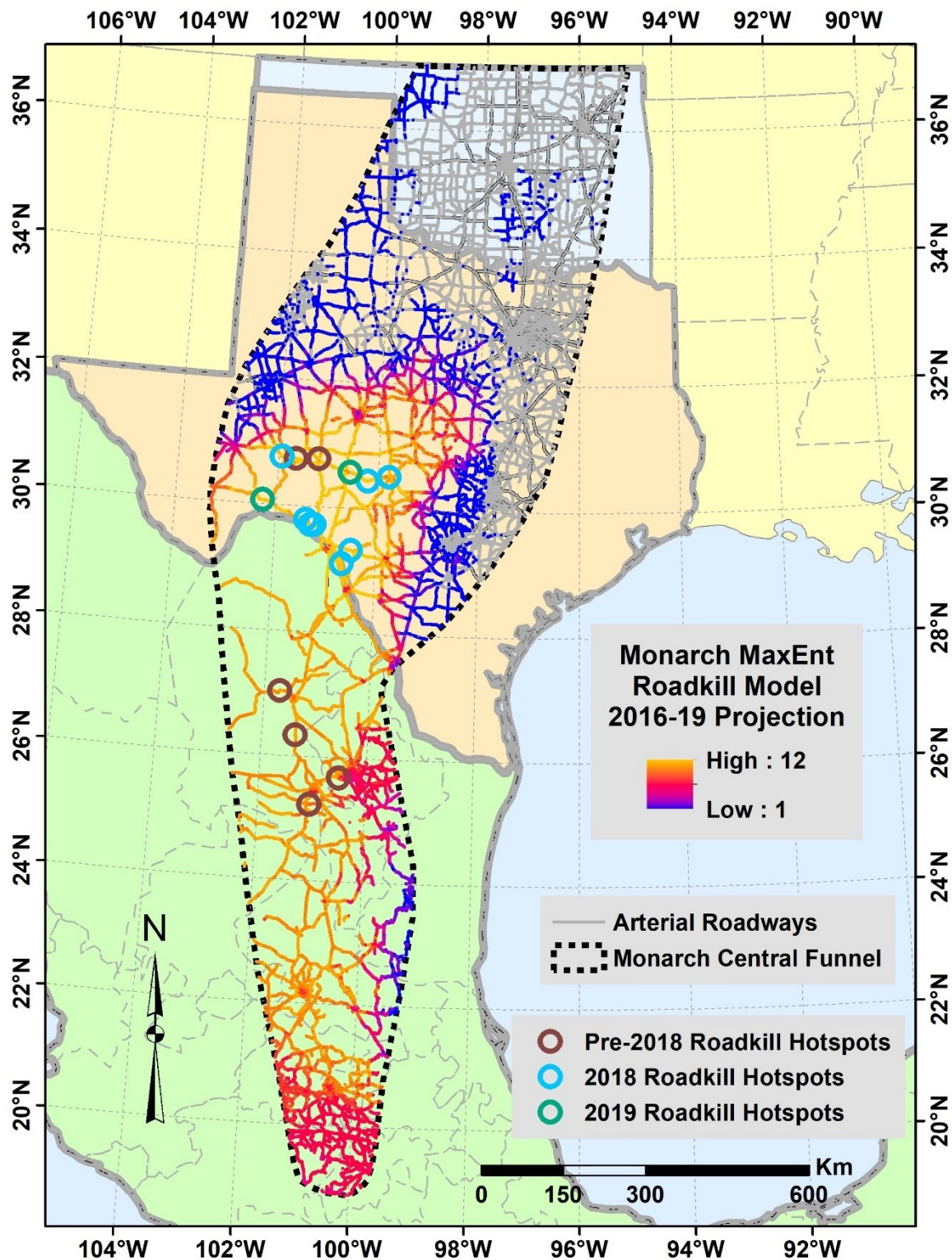
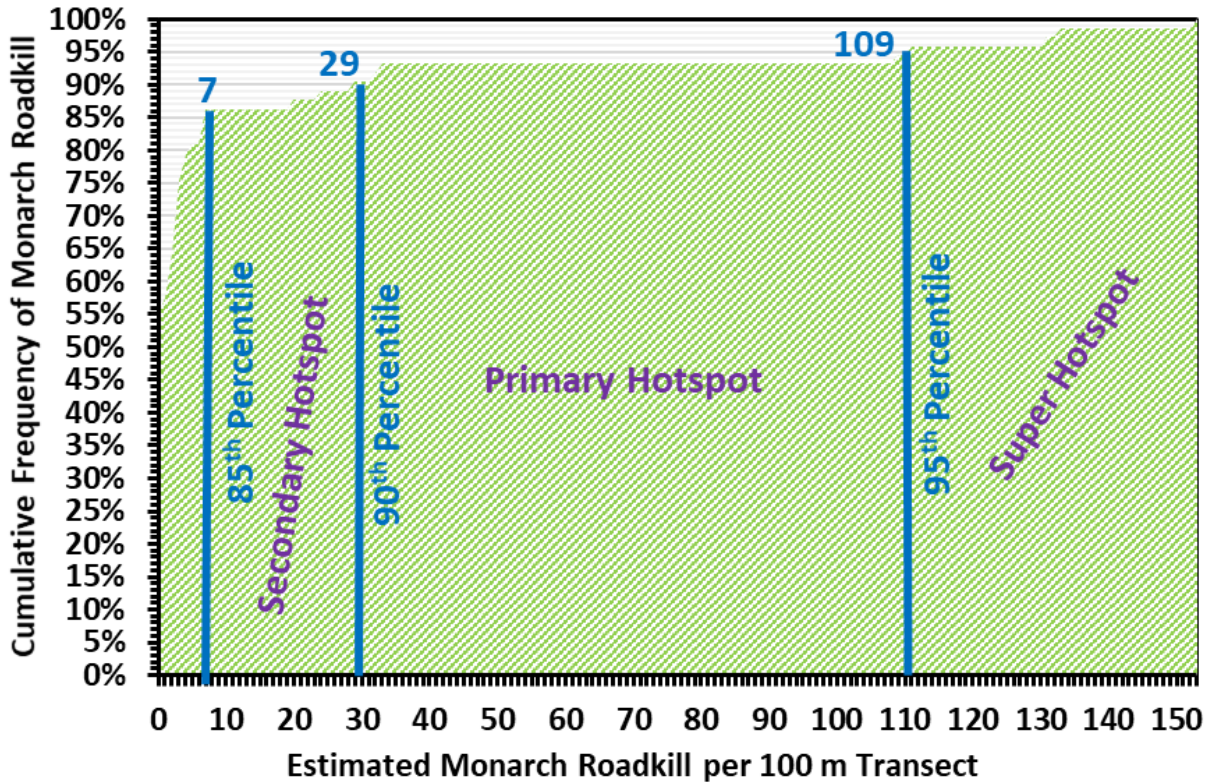


Figure 4. Monarch roadkill in the Central Funnel for 2016-2019 represented by MaxEnt feature subset ensemble of 12 models developed from subsets of six of 42 variables by cross validated random subset feature selection for high  $AUC_{psa}$ .





**Figure 5. Cumulative frequency of values for monarch roadkill per 100m transect for fall 2016 in the Texas Central Funnel (roadkill per transect values modified from Kantola et al. 2019 according to Tracy et al. 2020a).**

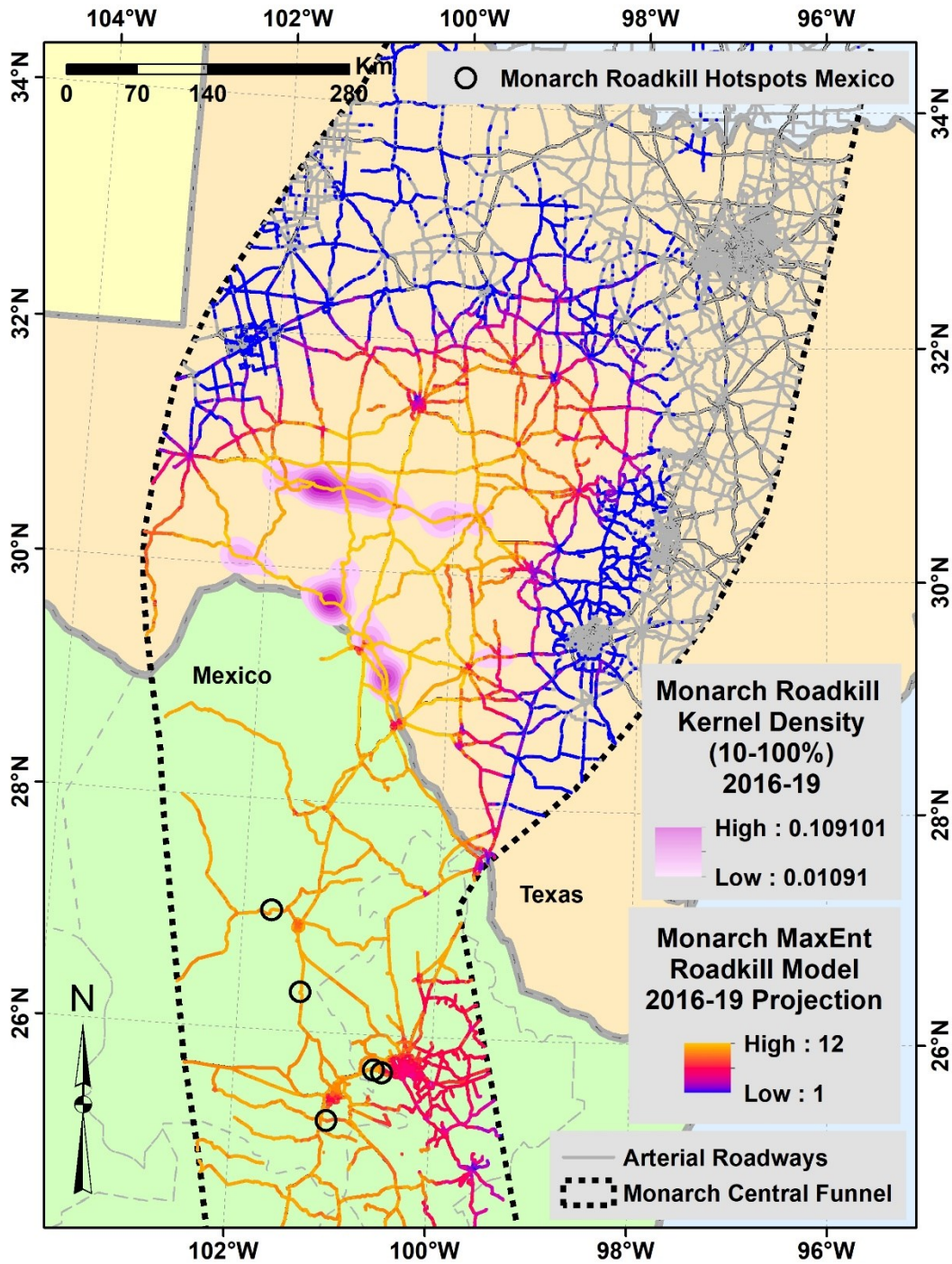


Figure 6. Monarch roadkill in the Central Funnel for 2016-2019 with KDE intensity surface for roadkill density at the 10-100% level.



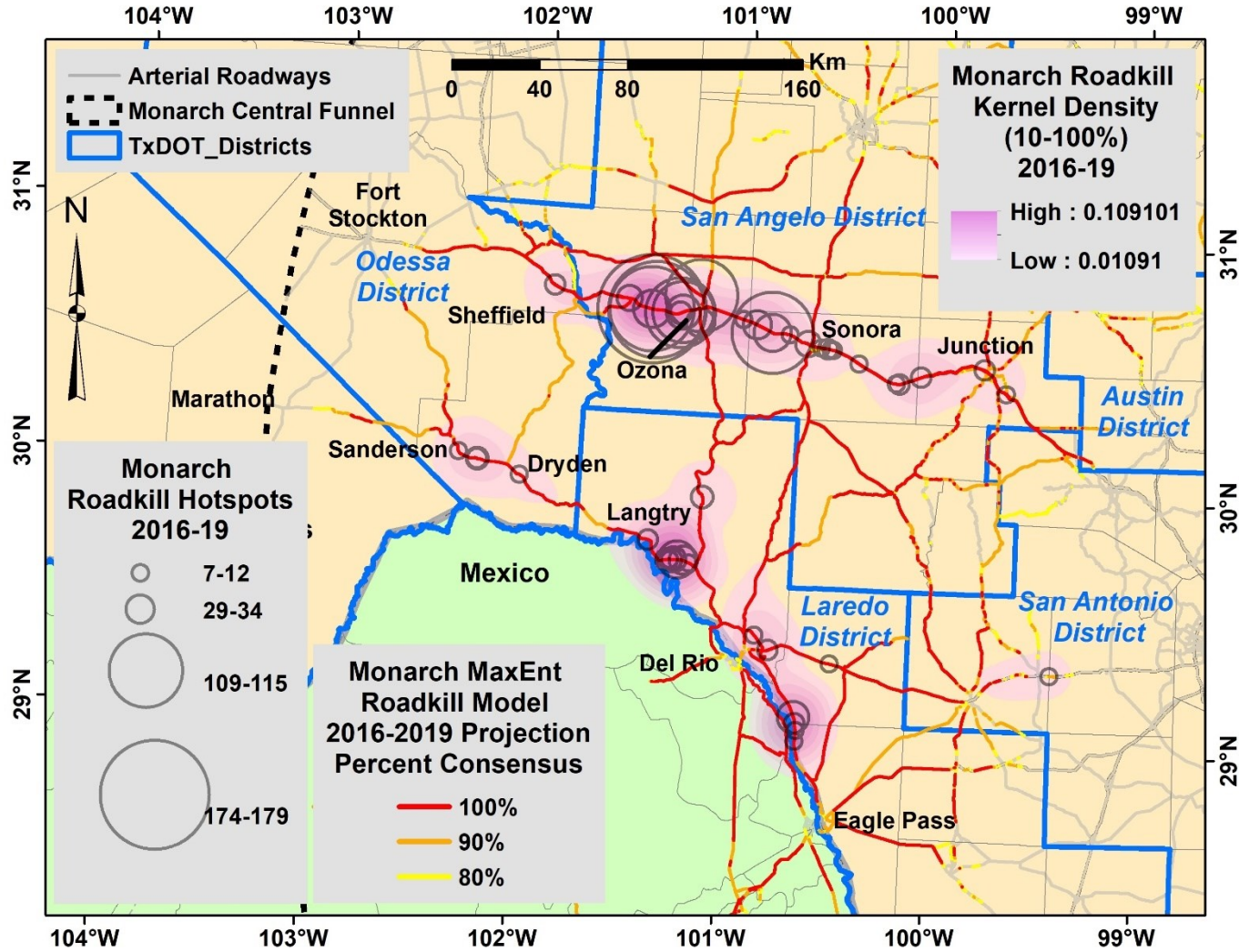
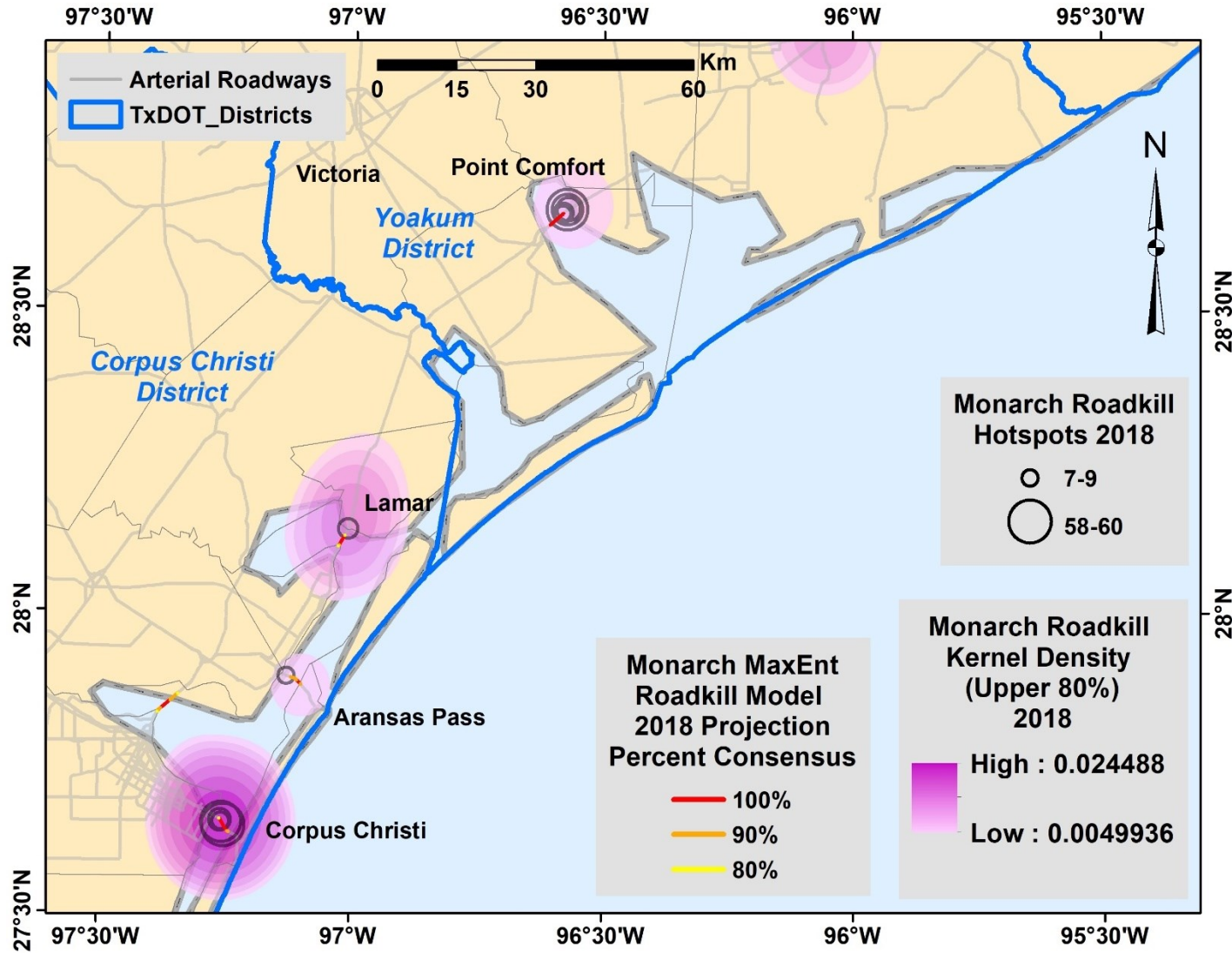


Figure 7. Monarch roadkill projections for 80-100% of MaxEnt models for 2016-2019 in the Central Funnel with KDE intensity surface for 2016-2019 roadkill density at the 10-100% level, and 2016-2019 monarch roadkill hotspots.



**Figure 8. Monarch roadkill projections for 80-100% of MaxEnt models for 2018 in the Coastal Funnel (from Tracy and Coulson 2019) with KDE intensity surface for 2018 roadkill density at the 20-100% level and 2018 monarch roadkill hotspots.**



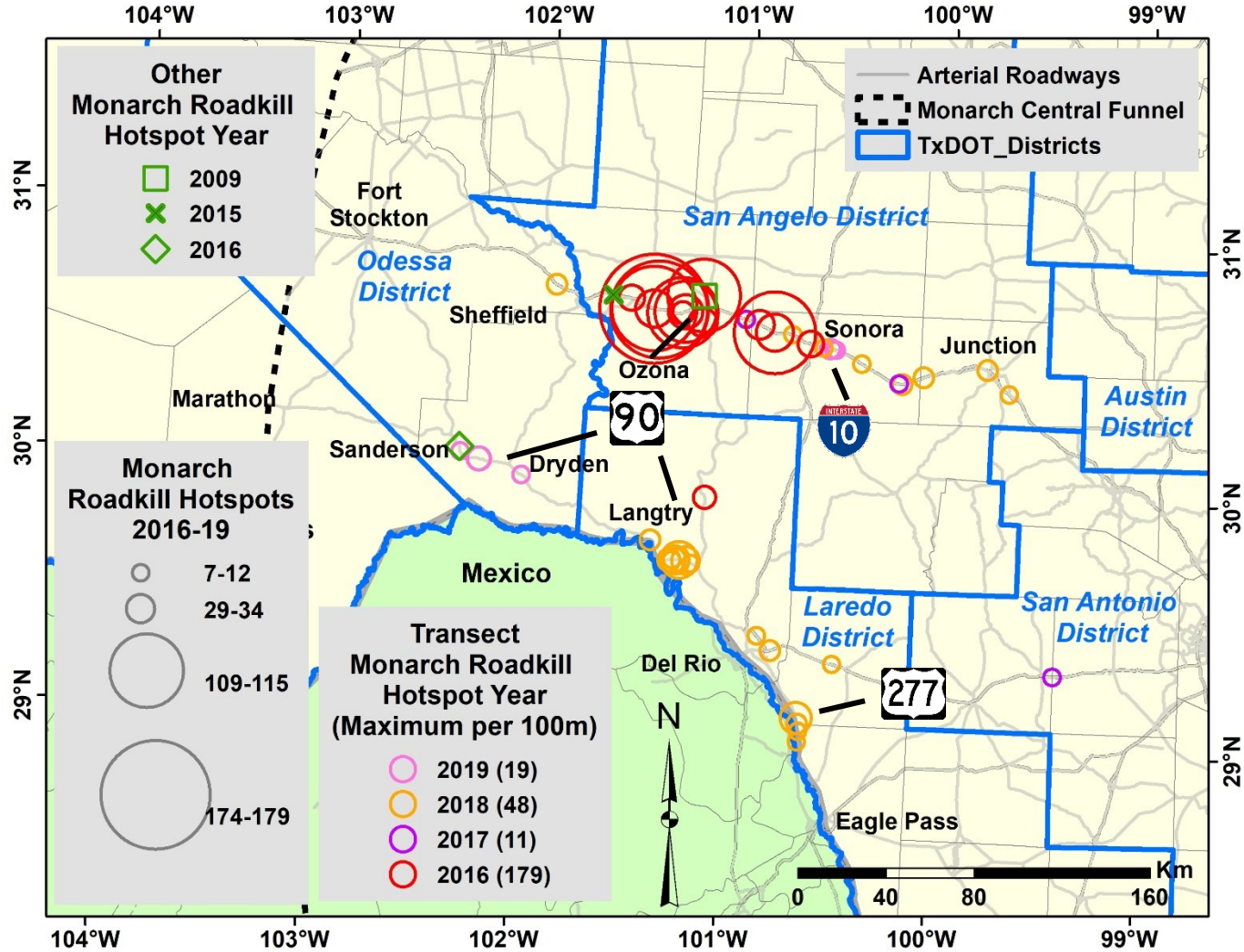


Figure 9. Annual distribution of monarch roadkill hotspot counts for 2016-2019 in the Texas Central Funnel.

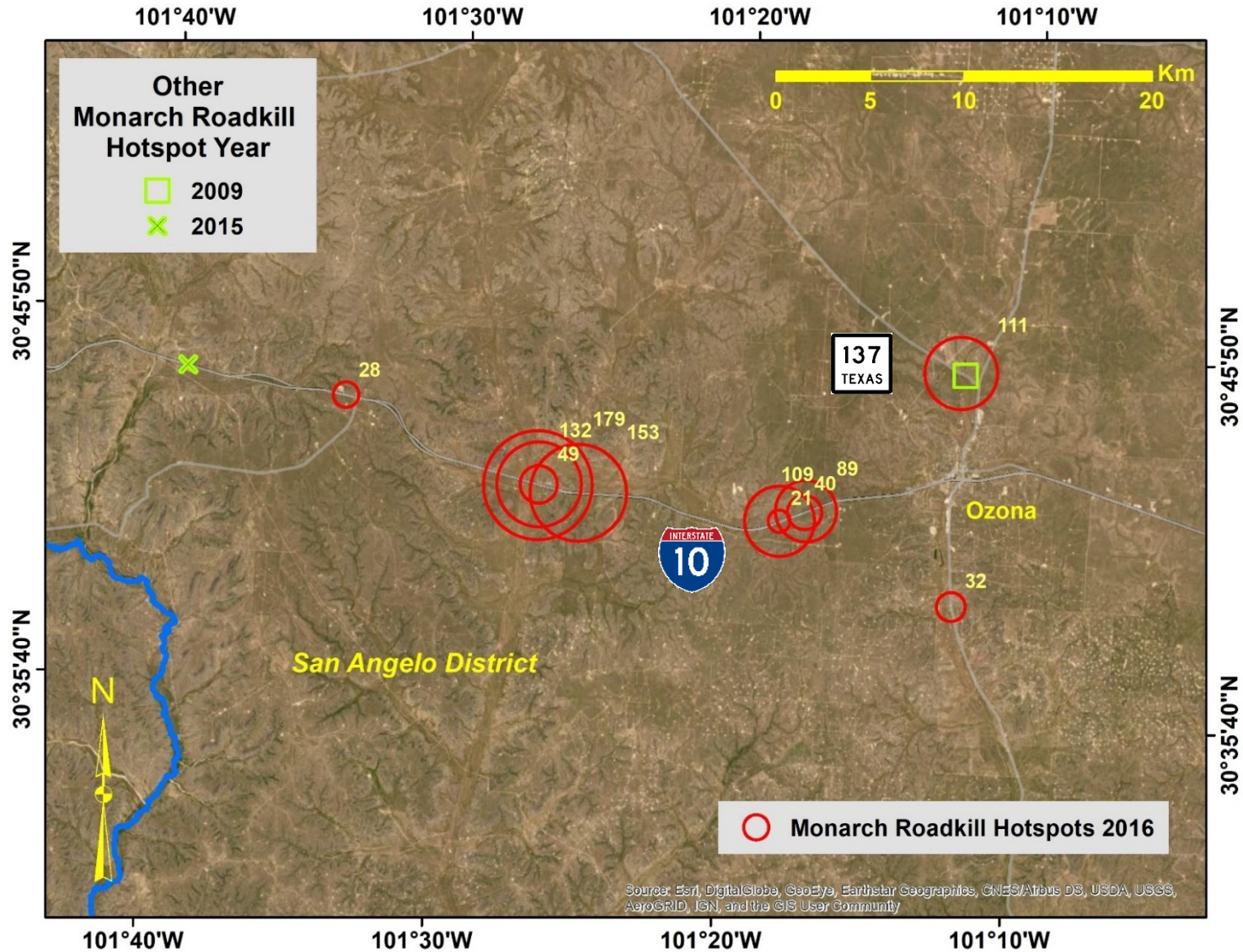


Figure 10. Distribution of monarch roadkill hotspot counts for 2016 west of Ozona in the Texas Central Funnel.



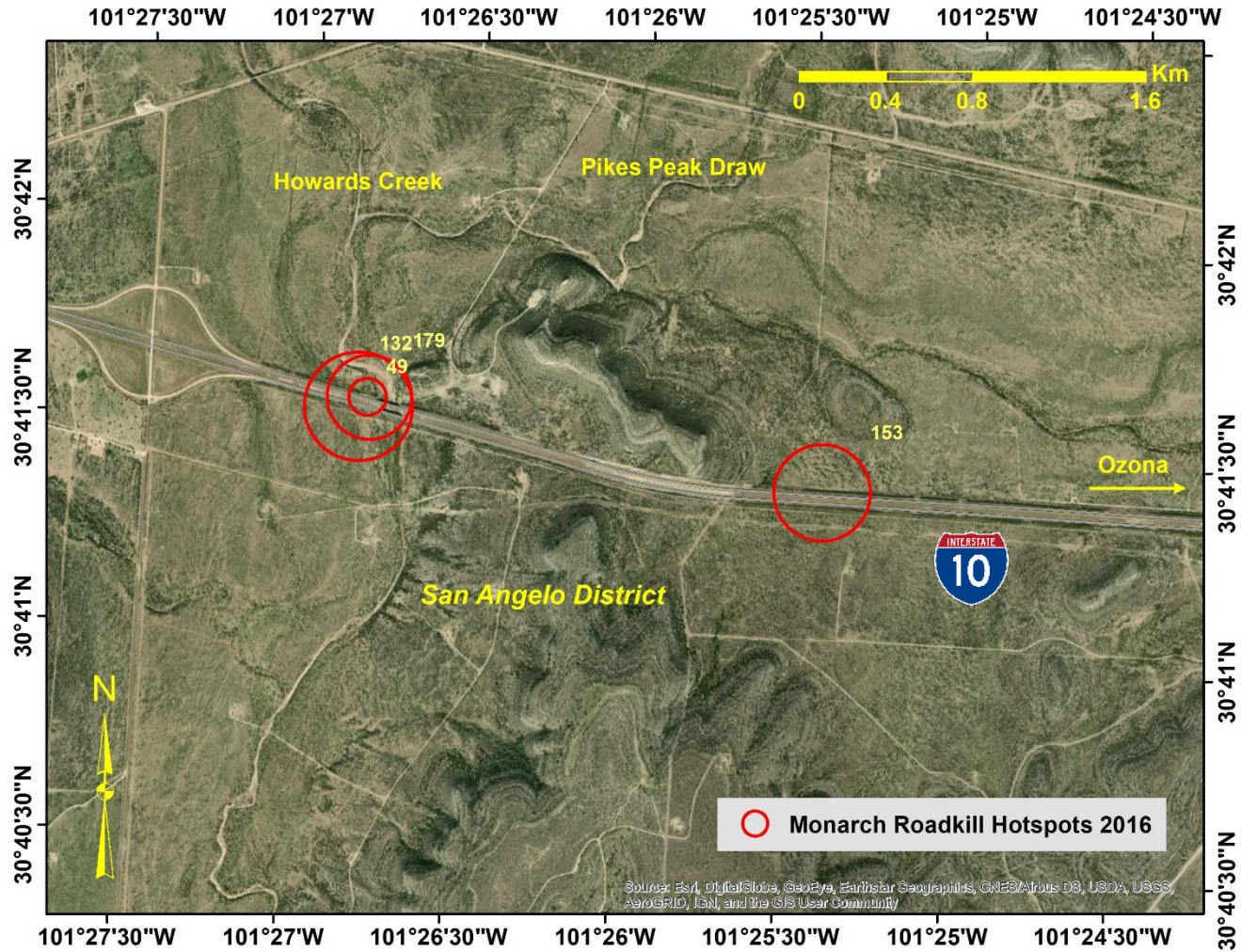


Figure 11. Distribution of monarch roadkill hotspot counts for 2016 near Howards Creek west of Ozona in the Texas Central Funnel.





Figure 12. Distribution of monarch roadkill hotspot counts for 2016 just west of Howards Creek west of Ozona in the Texas Central Funnel.





Figure 13. Distribution of monarch roadkill hotspot counts for 2016 east of Howards Creek and south of Pikes Peak Draw west of Ozona in the Texas Central Funnel.



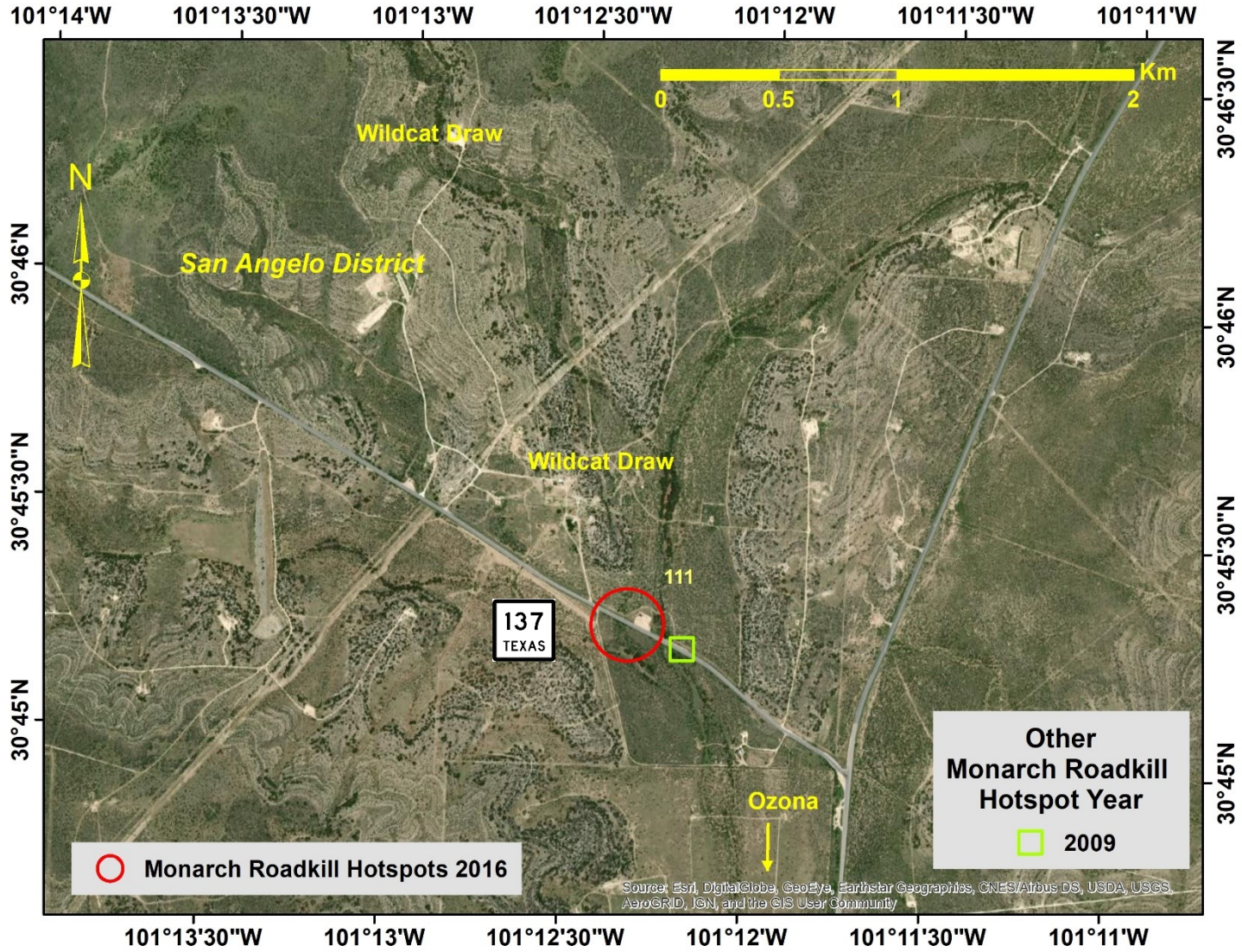


Figure 14. Distribution of monarch roadkill hotspot counts for 2016 south of Wildcat Draw on SH-137 north of Ozona in the Texas Central Funnel.



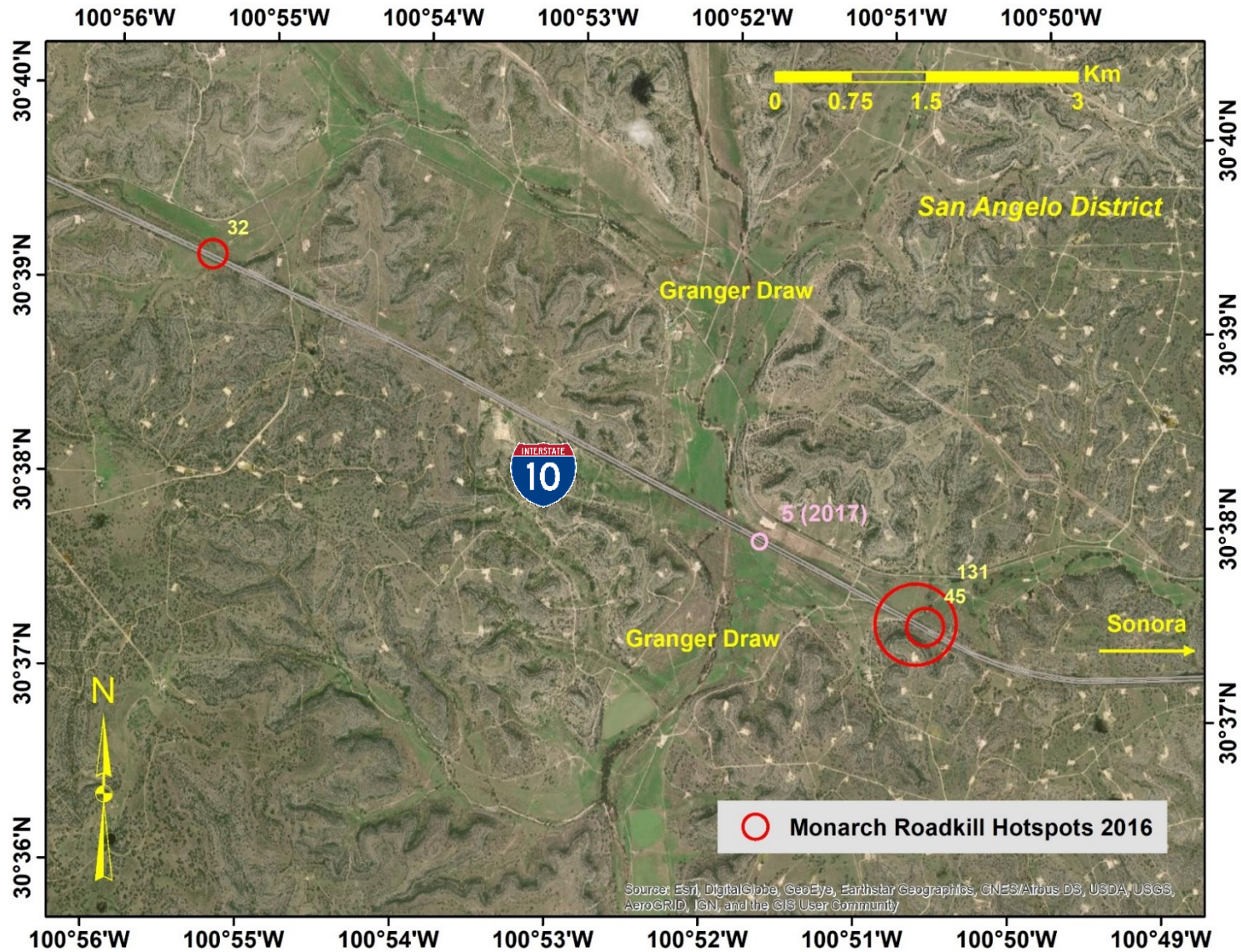


Figure 15. Distribution of monarch roadkill hotspot counts for 2016 east of Granger Draw on IH-10 west of Sonora in the Texas Central Funnel.



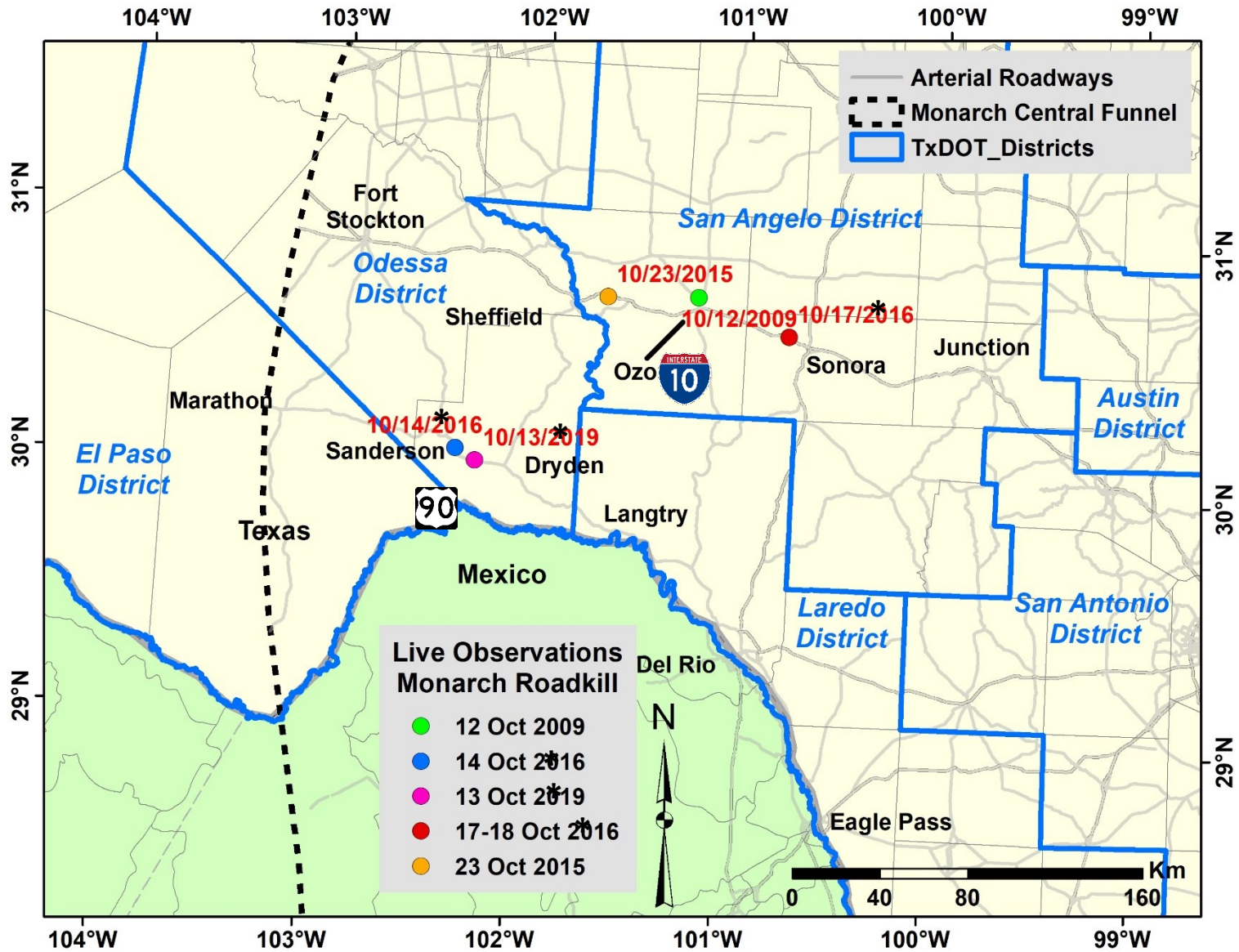


Figure 16. Observations of live monarch roadkill hotspots from 2009 to 2019 during October in the Texas Central Funnel (\* indicates roadkill associated with roosting by roadway) (see Table 3 for data).



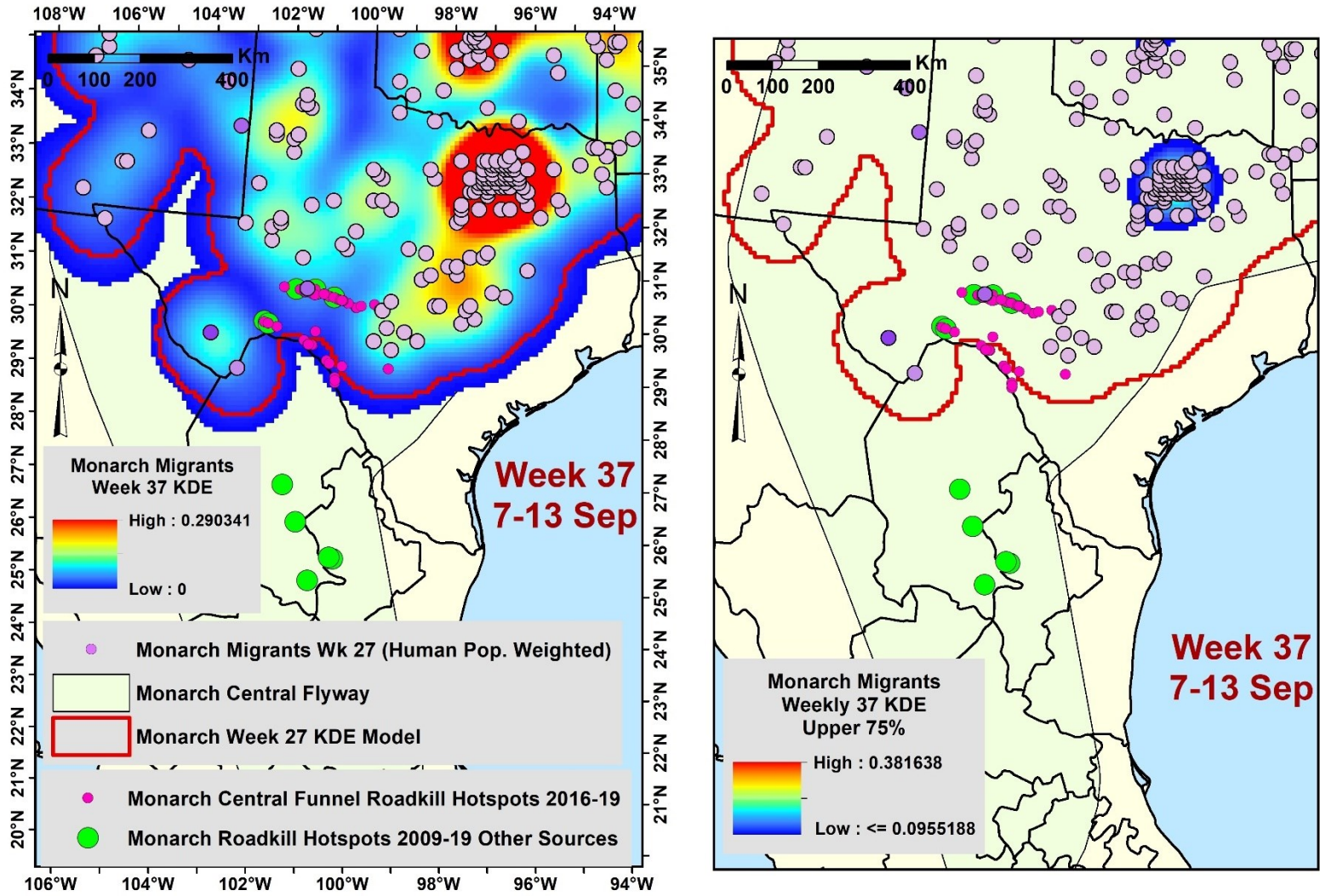
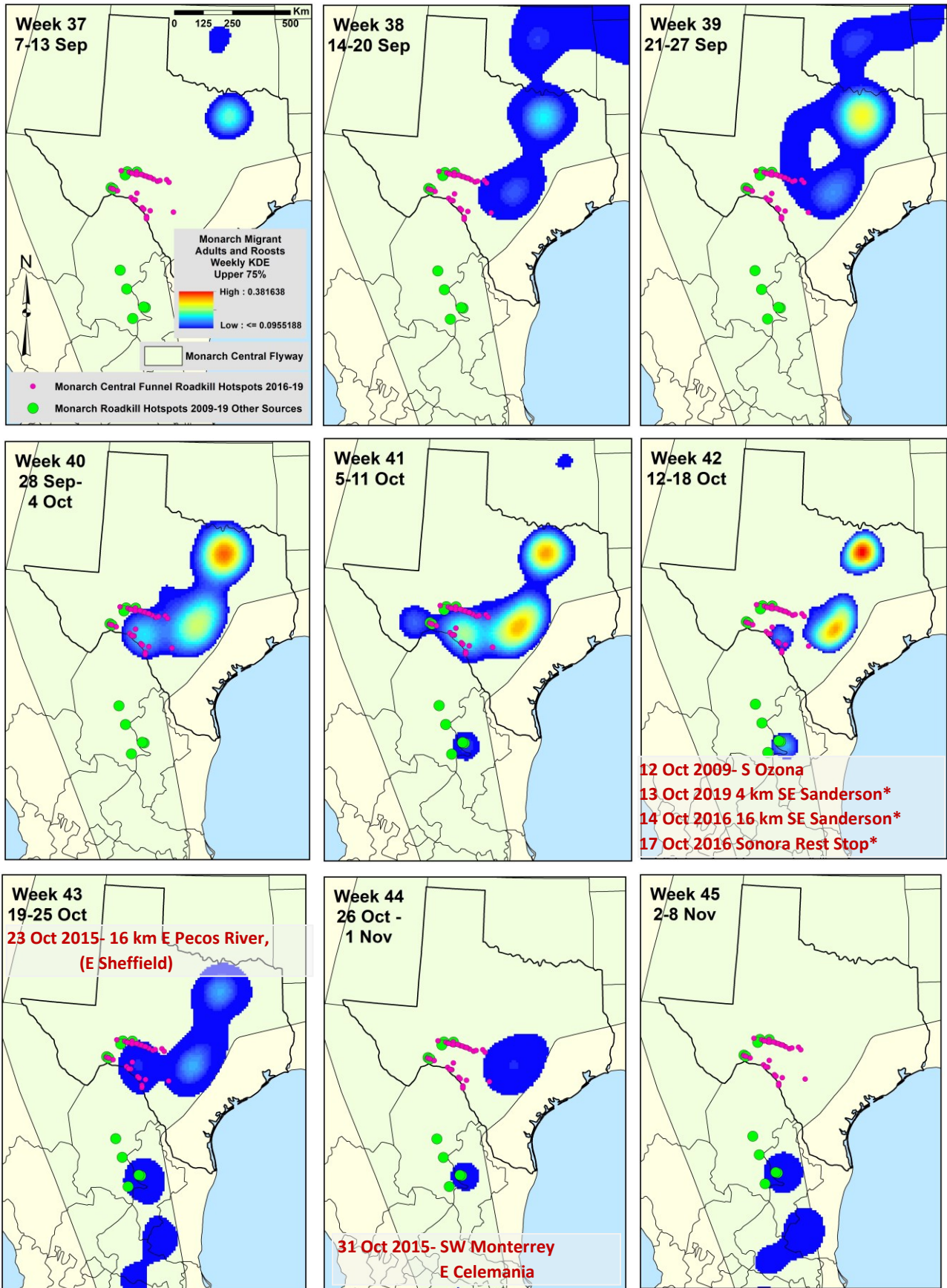


Figure 17. Monarch fall migratory adult and roost kernel density for week 27 of year with monarch roadkill hotspot locations (KDE model and data from Kantola et al. 2019b).



**Figure 18. Monarch fall migratory adult and roost kernel density (upper 75%) by week with monarch roadkill hotspot locations and date/locations of observed monarch roadkill in progress for week (\* indicates roadkill associated with roosting by roadway) (see Table 3 for live roadkill observations).**

## References

- Barbet-Massin, M., Jiguet, F., Albert, C.H. and Thuiller, W. 2012. Selecting pseudo-absences for species distribution models: how, where and how many?. *Methods in Ecology and Evolution*, 3(2): 327-338.
- Bellamy, C., Scott, C., Altringham, J. 2013. Multiscale, presence-only habitat suitability models: fine-resolution maps for eight bat species. *Journal of Applied Ecology*, 50:892-901.
- Center for International Earth Science Information Network (CIESIN) - Columbia University. 2016. *Gridded Population of the World, Version 4 (GPWv4): Population Density*. NASA Socioeconomic Data and Applications Center (SEDAC), Palisades, New York, Available at: <http://sedac.ciesin.columbia.edu/data/set/gpw-v4-population-density/data-download>
- Chen, J., Chen, J., Liao, A., Cao, X., Chen, L., Chen, X., He, C., Han, G., Peng, S., Lu, M., Zhang, W. 2015. Global land cover mapping at 30 m resolution: A POK-based operational approach. *ISPRS Journal of Photogrammetry and Remote Sensing*, 103:7-27.
- Evans, J.S., Oakleaf, J., Cushman, S.A., Theobald, D. 2014. *An ArcGIS Toolbox for Surface Gradient and Geomorphometric Modeling, Version 2.0-0*. Available at: <https://www.arcgis.com/home/item.html?id=63ffcecf3b2a45bf99a84cdaedefaccf>
- Fick, S.E., Hijmans, R.J. 2017. WorldClim 2: new 1-km spatial resolution climate surfaces for global land areas. *International Journal of Climatology* 37:4302-4315.
- Freeman, E.A., Moisen, G. 2008. PresenceAbsence: An R package for presence absence analysis. *Journal of Statistical Software*, 23:1–31 Available at: <http://www.jstatsoft.org/v23/i11/paper>.
- Geofabrik. 2017. OpenStreetMap Data Extracts. Available at: <http://download.geofabrik.de/>
- Hijmans, R.J., Cameron, S.E., Parra, J.L., Jones, P.G., Jarvis, A. 2005. A very high resolution interpolated climate surfaces for global land areas. *International Journal of Climatology*, 25:1965–1978
- Jiménez-Valverde, A., Lobo, J.M. and Hortal, J. 2008. Not as good as they seem: the importance of concepts in species distribution modelling. *Diversity and Distributions*, 14(6): 885-890.
- Journey North. 2020. *Monarch Butterflies: Maps*. Available at: <https://maps.journorth.org/map/?year=2020&map=monarch-adult-fall>



- Kantola T., Tracy, J.L., Baum, K.A., Quinn, M.A., Coulson, R.N. 2019a. Spatial risk assessment of eastern monarch butterfly road mortality during autumn migration within the southern corridor. *Biological Conservation*, 231:150-160.
- Kantola T., Tracy, J.L., Baum, K.A., Coulson, R.N. 2019b. Monarch weekly pre-migrant/migrant models, pp. 89-97. In: *Investigations on Monarch Butterflies (Danaus plexippus) in Texas using a Spatially Explicit Functional Connectivity Approach*, Section VI, Final Report IAC #16-5979, Texas Comptroller of Public Accounts, Austin, Texas. Available at: <https://comptroller.texas.gov/programs/natural-resources/docs/reports/CoulsonandBaumMonarchTAMUFinalReport14Jan2019.pdf>
- Liu, C., White, M., Newell, G. 2013. Selecting thresholds for the prediction of species occurrence with presence-only data. *Journal of Biogeography*, 40:778–789. <https://doi.org/10.1111/jbi.12058>
- Mora Alvarez, B.X., Carrera-Treviño, R., and Hobson, K.A. 2019. Mortality of monarch butterflies (*Danaus plexippus*) at two highway crossing “hotspots” during autumn migration in Northeast Mexico. *Frontiers in Ecology and Evolution*, 7: 273.
- NASA Jet Propulsion Laboratory (JPL). 2013. *NASA Shuttle Radar Topography Mission [SRTM] United States 1 Arc Second*. Version 3. 6oS, 69oW. NASA EOSDIS Land Processes DAAC, USGS Earth Resources Observation and Science (EROS) Center, Sioux Falls, South Dakota (<https://lpdaac.usgs.gov>). Available at: <http://dx.doi.org/10.5067/MEaSURES/SRTM/SRTMUS1.003>
- Ramp, D., Caldwell, J., Edwards, K.A., Warton, D., Croft, D.B. 2005. Modelling of wildlife fatality hotspots along the snowy mountain highway in New South Wales, Australia. *Biological Conservation*, 126:474-490.
- Tracy, J.L., Trabucco, A., Lawing, A.M., Giermakowski, J.T., Tchakerian, M., Drus, G.M. and Coulson, R.N. 2018. Random subset feature selection for ecological niche models of wildfire activity in Western North America. *Ecological Modelling*, 383:52-68.
- Tracy, J.L., Kantola, T., Baum, K.A. and Coulson, R.N. 2019. Modeling fall migration pathways and spatially identifying potential migratory hazards for the eastern monarch butterfly. *Landscape Ecology*, 34(2): 443-458.
- Tracy J.L., and Coulson R.N. 2019. *Eastern Monarch Butterfly Fall Migratory Roadkill Distribution and Hotspot Regions within the Coastal and Central Migratory Funnels of Texas*. Texas A&M Department of Entomology/Texas Transportation Institute Project Final Report. TxDOT Environmental Affairs Division, Austin, Texas. 32 pp. Available at:

[https://www.dropbox.com/s/an9wuzkyr54xdb0/TTI\\_TAMU%20Texas%20Monarch%20Roadkill%20Fall%202018%20Report.docx?dl=0](https://www.dropbox.com/s/an9wuzkyr54xdb0/TTI_TAMU%20Texas%20Monarch%20Roadkill%20Fall%202018%20Report.docx?dl=0)

Warren, D.L., Seifert, S.N. 2011. Ecological niche modeling in MaxEnt: the importance of model complexity and the performance of model selection criteria. *Ecological Applications* 21:335–342. <https://doi.org/10.1890/10-1171.1>

WorldClim. 2017. *WorldClim Version 1*. Available at: <http://www.worldclim.org/version1>

WorldClim2. 2017. *WorldClim Version 2*. Available at: <http://www.worldclim.org/version1>

## CHAPTER 4. FALL 2020 MONARCH ROADKILL MODELS

### Summary

Five continuous years of MaxEnt model projections for fall monarch roadkill in the Texas Central Funnel agree with simple extrapolations in revealing a biennial cycle of higher roadkill in the even-numbered years of 2016, 2018, and 2020, representing about 2.5% of the overwintering population, contrasting with lower roadkill in the odd-numbered years of 2017 and 2019, representing 0.8% of the overwintering population. Annual MaxEnt roadkill models generally agree in projecting perennial hotspot regions in both the Central and Coastal Funnels. The most consistent perennial hotspot zones consist of IH-10 between Sonora and Sheffield (San Angelo District) and Sanderson Canyon along US-90 (Odessa District) in the Central Funnel, and the Lavaca Bay (Yoakum District), Lyndon B Johnson and John F Kennedy (Corpus Christi District) causeways in the Coastal Funnel. These perennial hotspot zones should be the focus of any trials of direct mitigation to reduce monarch roadkill through seasonal monarch crossing and speed feedback signs and temporary mesh flight diverters.

### Methods

#### *Monarch Roadkill Observations*

Roadkill observations were made following the same protocol as Kantola et al. (2019), employing 100 x 1 meter transects spaced about every 20-30 km in both the Central and Coastal migratory funnels of Texas (Fig. 1; for details, see Part III Chapter 2).

#### *Environmental Variables*

Forty-four and forty-two environmental variables at 30.8 m resolution were developed for modeling roadkill in the Coast and Central funnels, respectively (Table A1), which is an expanded combination of the 30 variables employed in each of two previous studies (Kantola et al. 2019, Tracy and Coulson 2019). The variables include six road indices (trunk and motorways are now split rather than combined as in Part III Chapter 2), four human population indices, 22 topographic indices, eight land cover indices, and four climatic indices (for additional details, see Kantola et al. 2019 and Tracy and Coulson 2019)

#### *MaxEnt Roadkill Niche Models*

Roadkill presence and absence data were independently randomly spatially thinned to 2 km to reduce spatial autocorrelation. The final 30.8 m resolution MaxEnt models chosen by feature selection (see below) were calibrated to binary presence/absence format

using a threshold of maximum  $TSS_{pa}$  (Liu et al. 2013) and combined using frequency consensus to form a feature subset ensemble (for further details, see Tracy and Coulson 2019).

### *MaxEnt Roadkill Extrapolations*

Estimations of fall monarch roadkill per 100 m for both sides of the roadway were recalculated in a standardized way using transect data from 2016, 2017 (Kantola et al. 2019), 2018 (Tracy and Coulson 2019), and 2019 (Part III Chapter 2) (see Part III Chapter 3 for additional details on standardized extrapolation estimates across all road edges). We extrapolated the mean roadkill per km count rate (adjusted from 100 m) for the thinned presence point data throughout the Central Funnel by multiplying it with the length of kilometers of roadway with projected roadkill according to each binary MaxEnt presence/absence roadkill model. Binary MaxEnt output rasters were vectorized to polyline shapefiles using the ArcScan extension of ArcGIS (ESRI, Redlands, California) in order to estimate lengths of roadway projected with roadkill.

### *Feature Selection*

We utilized a modified version of the random subset feature selection algorithm (RSFSA-CV; Tracy et al. 2018, Tracy and Coulson 2019) to select a high performing ensemble of MaxEnt roadkill models using different subsets of the 42-44 environmental variables or predictors. The objective of RSFSA-CV is to produce MaxEnt models exhibiting higher accuracy in terms of presence/absence AUC ( $AUC_{pa}$ ), lower complexity, as measured by corrected Akaike information criterion ( $AICc_{bg,r}$ ,  $AICc$  computed from background point data), and lower overfitting, as measured by  $AUC_{pa\_diff}$  (training  $AUC_{pa}$  minus test  $AUC_{pa}$ ; Warren and Seifert 2011) than random feature subsets. The RSFSA-CV was used to first select hundreds of random subsets of variables ranging from one to eight of the 41 total variables, with a restriction of  $|0.7|$  for intervariable correlation within each subset. MaxEnt models were developed and evaluated from the various sized random subsets to choose an optimally sized feature subset. Once a variable subset size was chosen, hundreds to thousands of MaxEnt models were developed from random subsets of the chosen size and ranked separately by  $AUC_{pa}$  or  $AICc_{bg}$  to measure performance against random MaxEnt models of the same feature subset size. Either  $AUC_{pa}$  or  $AICc_{bg}$  was then chosen to rank the top MaxEnt models for the final roadkill spatial projections. We kept a random 12 models from the top ranked MaxEnt roadkill models, four from each of three RSFSA-CV replications. We jointly ranked the variables in the top feature-selected MaxEnt models for mean variable permutation importance and frequency of variable appearance in the models (for additional details see Tracy et al. 2018, 2019).



## Results and Discussion

### *MaxEnt Roadkill Niche Models*

#### Central Funnel

A total of 50 out of 115, or 43%, of unthinned Central Funnel transects had monarch roadkill in the fall of 2020, ranging from 1.43 to 50 monarchs per 100 m (Fig. 2C). This is much higher than the about 23% of 111 unthinned Central Funnel transects that had monarch roadkill in the fall of 2019, reaching a maximum of 16 monarchs per 100m (Part III Chapter 2).

Feature selection by RSFSA-CV revealed that subsets of seven of 42 variables were sufficient for providing increased accuracy ( $AUC_{pa}$ ) and lower complexity ( $AIC_{cbg}$ ) and overfitting ( $AUC_{pa,diff}$ ) (Fig. 3A-C). Selection of models by either  $AUC_{pa}$  or  $AIC_{cbg}$  provided improvement over random models in only one of three feature selection replicates (Fig. 3D-E), with no improvement in overfitting (Fig. 3F). For consistency with the 2019 analysis, we chose  $AIC_{cbg}$  as the model selection criterion, although it provided no advantage over  $AUC_{pa}$ .

The accuracy of the fall 2020 MaxEnt Central Funnel monarch roadkill models was marginal with a presence/absence  $AUC_{pa}$  of 0.7, but good for the MaxEnt default background  $AUC_{bgp}$  of 0.79 (Table 1). These accuracy values are higher than for the fall 2019 MaxEnt Central Funnel roadkill models, but lower than for models of previous years from 2016 to 2018 (Kantola et al. 2019, Tracy and Coulson 2019).

Variables across all five categories of indices were important in the fall 2020 Central Funnel monarch roadkill niche modelling (Table 2). Among the ten highly ranked variables in the feature selected MaxEnt models were four human population indices, two road indices, two land cover indices, one topographic index, and one climate index. Similar to our previous studies, MaxEnt models projected higher monarch roadkill with lower levels of human population, road density, artificial surface cover, and fall precipitation (Fig. 5A,C-F). Monarch roadkill was also projected as lower on secondary roads (or higher away from close proximity to them) (Fig. 5B), indicating that roadkill was more associated with higher order primary, motorway, and trunk road types. For both 2020 and 2019, monarch roadkill was projected as higher with higher percent cover of shrubland (Fig. 5C).

As in previous years, the 80, 90, and 100 percent overlap of the top 12 fall 2020 Central Funnel Maxent roadkill models predicted highest monarch roadkill in the southwestern portion of the Central Funnel in Texas (Figs. 9, 10). The highest areas of projected roadkill in 2020 extended farther out from the southwestern region compared to 2019, especially to the northeast (Fig. 9). In addition, more models projected roadkill in the Junction to Sheffield IH-10 and Sanderson to Del Rio US-90 hotspot zones compared to 2019 and many more hotspots were found along IH-10 (Fig. 10). The most consistent

hotspots from year to year appeared between Sonora and Sheffield along IH-10 (San Angelo District) and around Sanderson Canyon on US-90 (Odessa District) (Figs., 2, 10; see Part III Chapters 2 and 4 for more discussion of fall 2019 and 2020 monarch roadkill hotspots).

### Coastal Funnel

A total of 17 out of 60, or 28%, of unthinned Coastal Funnel transects had monarch roadkill in the fall of 2020, ranging from 1.43 to 52 monarchs per 100 m (Fig. 2C). This is much higher than the about three out of 48 (6%) unthinned Coastal Funnel transects that had monarch roadkill in the fall of 2019 (Part III Chapter 2). The 17 monarch roadkill presence points for 2020 represents close to the minimum number of points needed for developing the Coastal Funnel MaxEnt models.

Subsets of only two of 44 variables were indicated by RSFSA-CV as sufficient for providing increased accuracy ( $AUC_{pa}$ ) and lower complexity ( $AIC_{cbg}$ ) and overfitting ( $AUC_{pa\_diff}$ ) (Fig. 4A-C). Selection of models by  $AIC_{cbg}$  provided improvement in  $AUC_{pa}$  and  $AUC_{bgp}$  in all three feature selection replicates (Fig. 4D-E), with two replicates also showing improvement in overfitting (Fig. 4F). These results were slightly better than seen for  $AUC_{pa}$  ranked models, and we chose  $AIC_{cbg}$  as the model selection criterion.

The accuracy of the fall 2020 MaxEnt Coastal Funnel monarch roadkill models was good, with presence/absence  $AUC_{pa}$  at 0.8 and MaxEnt default background  $AUC_{bgp}$  at 0.86 (Table 1). These accuracy values are much higher than for the fall 2018 Coastal Funnel roadkill models which had both  $AUC_{pa}$  and  $AUC_{bgp}$  at around 0.7 (Tracy and Coulson 2019). The fall 2020 Coastal Funnel MaxEnt roadkill projections were much more localized to coastal areas compared to 2018 (Fig. 8).

As with the Central Funnel models above, variables across all five categories of indices were important in the fall 2020 Coastal Funnel monarch roadkill niche modelling (Table 2). Among the ten highly ranked variables in the feature selected MaxEnt models were three topographic indices, three human population indices, two road indices, one land cover index, and one climate index. Similar to our fall 2018 Coastal Funnel roadkill models, the mean cover of sea in a 3 km radius was the most important variable, with higher sea cover correlated with higher roadkill projections (Fig. 6A). Fall 2020 Coastal Funnel roadkill projections also increased with lower values for distance to the sea, elevation, distance to primary roads, and human population density (Fig. 6C,D,E,F). Higher values of fall quarter wind speed were associated with roadkill projections for fall 2020 (Fig. 6C) and fall 2018.

The 80, 90, and 100 percent overlap of the top Coastal Funnel Maxent roadkill models projected highest monarch roadkill in coastal causeways for both 2018 and 2020, which corresponded with major hotspot zones in these years (Fig. 11). Roadkill hotspots in both 2018 and 2020 occurred along the Lavaca Bay (San Angelo District), Lyndon B Johnson, and John F Kennedy (Corpus Christ District) causeways (Fig. 11) (see Tracy and

Coulson 2019 and Part III Chapter 4 for more discussion of fall 2018 and 2020 monarch roadkill hotspots).

### *MaxEnt Roadkill Extrapolations*

The MaxEnt estimated percentage of overwintering monarchs subject to roadkill in the Texas Central Funnel from 2016 to 2020 (Table 3), closely followed estimates from simple extrapolation (Part III Chapter 2; Table A4, Fig. 12). Both MaxEnt and simple extrapolation methods resolved a biennial pattern in roadkill where Texas Central Funnel monarch roadkill represents about 2.5% of the overwintering population in even numbered years (2016, 2018, 2020) and about 0.8% of the overwintering population in odd numbered years (2017 and 2019). A similar pattern was seen for the Coastal Funnel, with the highest roadkill projected in 2018 and 2020 compared to 2019. MaxEnt roadkill projections for the Coastal Funnel of about 0.01 to 0.04% of the overwintering population were much lower than projections of 0.1 to 0.17% by simple extrapolation, probably because MaxEnt model projections of Coastal Funnel roadkill are localized along hotspot areas near the coast.

Further continuous monitoring of annual monarch roadkill in the Texas Central and Coastal funnels is needed to assess the strength of the biennial trends in roadkill numbers. It is possible that biennial patterns in prevailing wind directions and speed in Texas could be influencing monarch roadkill numbers. Headwinds can influence monarchs to fly closer to the ground, increasing roadkill incidence (Kantola et al. 2016), and these headwinds could occur more frequently or intensely in even numbered years. The Quasi-Biennial Oscillation (QBO) of alternating easterly versus westerly equatorial stratospheric wind layers operates on an average 28-month cycle (ca. 14 months between easterly and westerly wind patterns), and it can influence global weather (Baldwin et al. 2001). Weather influences from the QBO are complex, varying regionally and over time (decadally) (Camargo and Sobel 2010), and their influence on seasonally prevailing winds in Texas is unknown.

### *Conclusion*

Five years of fall Central Funnel monarch roadkill models indicate a biennial pattern of monarch roadkill fluctuating between 2.5% of the overwintering population in even-numbered years to 0.8% in odd-numbered years from 2016 to 2020. The models generally agree in projecting high roadkill in the perennial Central Funnel monarch roadkill hotspot zones along IH-10 from Sonora to Sheffield and around Sanderson Canyon on US-90. The two fall Coastal Funnel monarch roadkill models projected similar lower levels of roadkill of around 0.01 to 0.04% in 2018 and 2020, with highest projections correlating with observed coastal causeway hotspot zones, including the Lavaca Bay, Lyndon B Johnson and John F Kennedy causeways. Any trials for potential direct monarch roadkill mitigation, such as seasonal monarch crossing signs and speed

feedback signs and temporary mesh diversion netting, should made in these perennial hotspot zones of the Texas Central and Coastal funnels,



## Tables

**Table 1. Fall 2020 monarch roadkill MaxEnt model train and test Area Under the Curve (AUC) accuracy statistics and overfitting ( $AUC_{diff} = AUC_{train} - AUC_{test}$ ) ( $\bar{X} \pm SD$ ) from  $n = 12$  models per migratory funnel that were selected by the random subset feature selection algorithm.**

Migratory Funnel	Pseudoabsence AUC ( $AUC_{psa}$ )			Background/Presence AUC ( $AUC_{bgp}$ ) <sup>a</sup>			$AUC_{bgp}$ % of $AUC_{psa}$
	Train	Test	Diff	Train	Test	Diff	Test
Central	0.750 ± 0.037	0.702 ± 0.065	0.048 ± 0.050	0.834 ± 0.032	0.789 ± 0.044	0.045 ± 0.032	112.4%
Coastal	0.883 ± 0.034	0.799 ± 0.055	0.084 ± 0.038	0.907 ± 0.031	0.857 ± 0.038	0.05 ± 0.026	107.3%

<sup>a</sup>Default AUC type for MaxEnt models.

**Table 2. Monarch fall 2020 Central and Coastal migratory funnel roadkill MaxEnt model 10 top ranked variables across variable correlation groups from three replicates of 250 selected models from random subset feature selection.<sup>a</sup>**

Variable (n)	Correlation Group	Joint Ranking <sup>b</sup>	Mean Permutation Importance	Mean Frequency in Models
<i>Central Funnel</i>				
<i>seconddist</i> (3)	1	2.67 ± 1.53	45.03 ± 12.21	55.33 ± 18.58
<i>popden</i> (2)	2	3.00 ± 1.41	53.20 ± 2.00	28.00 ± 5.66
<i>mnpopden3kr</i> (3)	2	3.67 ± 2.52	45.71 ± 7.76	41.33 ± 3.79
<i>mnpopden9kr</i> (3)	2	6.33 ± 5.13	38.81 ± 11.25	45.00 ± 20.81
<i>hiurbdist</i> (3)	2	10.33 ± 2.52	32.10 ± 6.38	30.00 ± 1.73
<i>shrub_500mr</i> (3)	3	3.67 ± 2.08	38.63 ± 8.19	56.67 ± 2.89
<i>artsur_500mr</i> (4)	4	5.00 ± 3.61	37.77 ± 11.09	65.67 ± 39.27
<i>roadden3kr</i> (4)	4	14.00 ± 1.73	27.29 ± 6.01	20.33 ± 7.23
<i>prec_ann</i> (5)	5	8.67 ± 4.73	26.15 ± 17.96	42.33 ± 6.11
<i>elev</i> (5)	5	9.00 ± 2.00	30.33 ± 7.93	29.00 ± 3.61
<i>Coastal Funnel</i>				
<i>mnsea3kr</i> (3)	1	1.00 ± 0.00	91.93 ± 4.49	223.00 ± 24.43
<i>wnsp_autq</i> (1)	2	2.00	67.05	49.00
<i>elev</i> (1)	2	9.00	2.89	4.00
<i>seadist</i> (1)	2	11.00	3.61	1.00
<i>primarydist</i> (3)	3	2.33 ± 0.58	67.89 ± 4.30	27.33 ± 4.04
<i>mnpopden3kr</i> (3)	4	3.67 ± 1.15	29.91 ± 16.10	14.33 ± 4.93
<i>mnpopden9kr</i> (3)	4	6.67 ± 3.06	30.58 ± 20.59	12.00 ± 6.56
<i>artsur_500mr</i> (3)	4	9.00 ± 6.24	15.68 ± 17.06	10.67 ± 3.06
<i>roadden3kr</i> (2)	4	9.50 ± 0.71	8.00 ± 7.95	5.50 ± 2.12
<i>popden</i> (3)	4	10.00 ± 4.58	10.73 ± 10.30	7.67 ± 4.62

<sup>a</sup>For variable abbreviations see Table A1. n = number out of three feature selection replicates in which variable appeared. Not all variables were used in our randomly selected 12 top models (see Tables A2-A3).

<sup>b</sup>Variable joint ranking by combination of permutation importance and frequency in all RSFSA-CV selected models (c.f., Tracy et al. 2018).

**Table 3. Estimated fall monarch roadkill using MaxEnt model projections over portions of migratory funnels in relation to overwintering estimates.**

Location/Year (Number Models) (Source)	Thinned (2 km) Presence Roadkill per 100m <sup>a</sup>	Kilometers roadways projected with roadkill		Estimated Roadkill (millions) <sup>b</sup>		Area Monarchs Over- wintering in Mexico (Ha) (Monarch Watch 2021)	Estimated Over- wintering (millions) <sup>c</sup>	Roadkill as Percent Overwintering Population	
		Entire Funnel	Texas Portion	Entire Funnel	Texas Portio n			Entire Funnel	Texas Portio n
<b>Central Funnel</b>									
2016 (10) (2016-17; Kantola et al. 2019)	11.08 ± 20.52 (32) [1.43-94.38]	26,772 ± 6,762	13,131 ± 3,612	2.97 ± 0.75	1.45 ± 0.40	2.91	61.401	4.83 ± 1.22	2.37 ± 0.65
2017 (10) (2016-17; Kantola et al. 2019)	2.76 ± 1.68 (21) [2-7.15]	26,772 ± 6,762	13,131 ± 3,612	0.74 ± 0.19	0.36 ± 0.10	2.48	52.328	1.41 ± 0.36	0.69 ± 0.19
2018 (9) (Tracy and Coulson 2019)	9.30 ± 9.60 (52) [1-48]	52,888 ± 18,026	27,408 ± 8,193	4.92 ± 1.68	2.55 ± 0.76	6.05	127.655	3.85 ± 1.31	2.00 ± 0.60
2019 (11) (Part III Chapter 2)	3.54 ± 3.73 (21) [1-16]	30,188 ± 19,669	16,611 ± 11,434	1.07 ± 0.70	0.59 ± 0.41	2.83	59.713	1.79 ± 1.17	0.99 ± 0.68
2020 (12) (AIC ranked; This Study)	7.65 ± 11.31 (50) [1.43-50]	18,313 ± 11,472	11,756 ± 6,333	1.40 ± 0.88	0.90 ± 0.48	2.10	44.31	3.16 ± 1.98	2.03 ± 1.09
2020 (12) (AUC ranked; This Study)	7.65 ± 11.31 (50) [1.43-50]	23,063 ± 11,762	12,664 ± 6,557	1.76 ± 0.90	0.97 ± 0.50	2.10	44.31	3.98 ± 2.03	2.19 ± 1.13
<b>Coastal Funnel</b>									
2018 (6) (Tracy and Coulson 2019)	2.94 ± 3.00 (18) [1-13]	2,508 ± 5,874	1,558 ± 3,701	0.07 ± 0.17	0.05 ± 0.11	6.05	127.655	0.06 ± 0.14	0.04 ± 0.09
2019 <sup>d</sup> (Part III Chapter 2)	1.84 ± 0.29 (4) [1.43-2]	--	--	--	--	2.83	59.713	--	--
2020 (12) (This Study)	3.79 ± 4.38 (14) [1.43-15]	234 ± 171	43 ± 52	0.01 ± 0.01	± 0.002	2.10	44.31	0.03 ± .01	0.01 ± 0.004

---

<sup>a</sup>Thinned roadkill rates from transects of roadkill presence data thinned to 2 km and incorporating estimates for all road edges (see Part III Chapter 3).

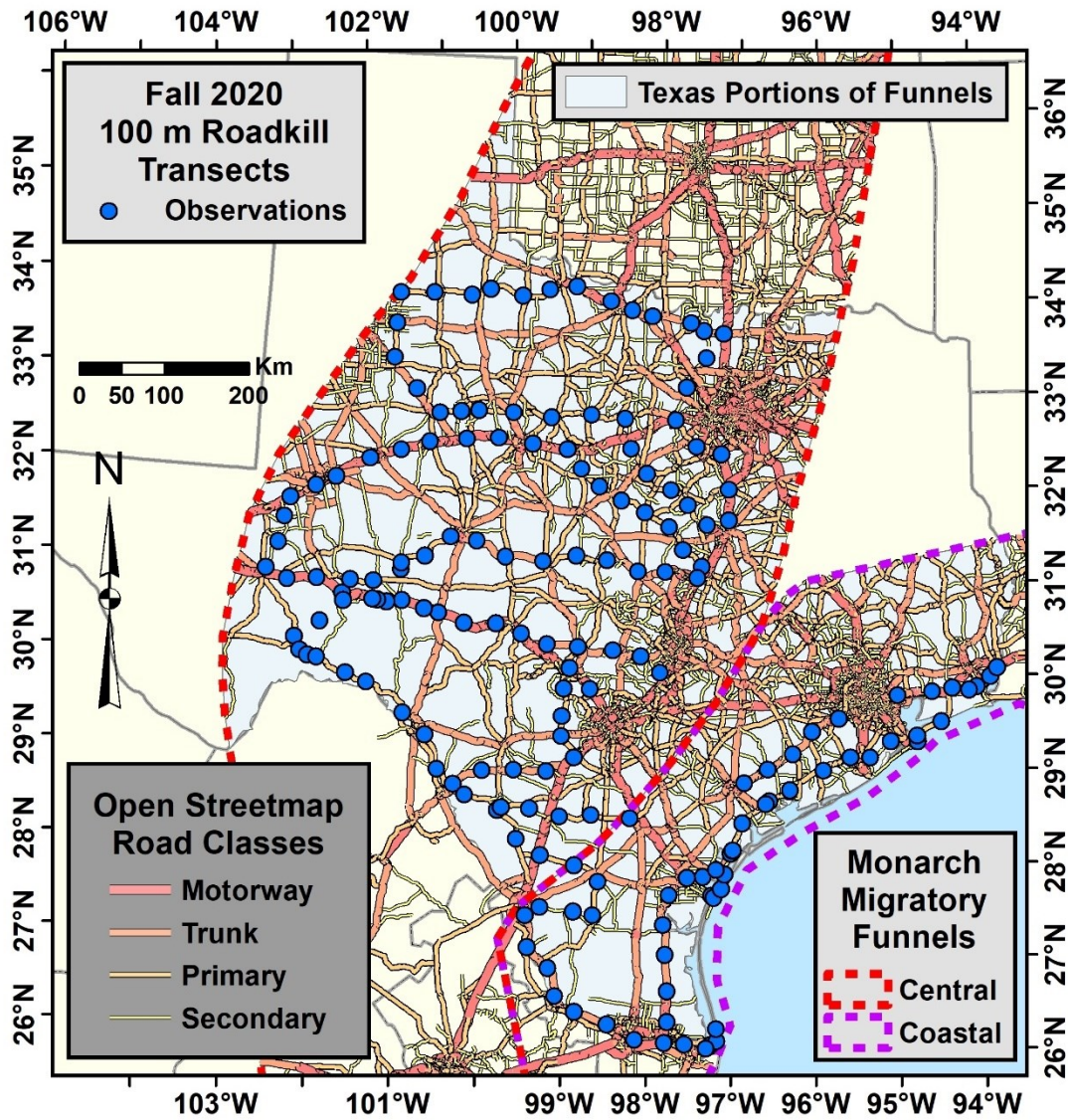
<sup>b</sup>Product of thinned roadkill rates x 10 (1000m/100m transect) and kilometers roadway.

<sup>c</sup>Based on Mexican overwintering population hectares of overwintering monarchs (Monarch Watch 2021) multiplied by 21,100,000 monarchs per hectare (Thogmartin et al. 2017).

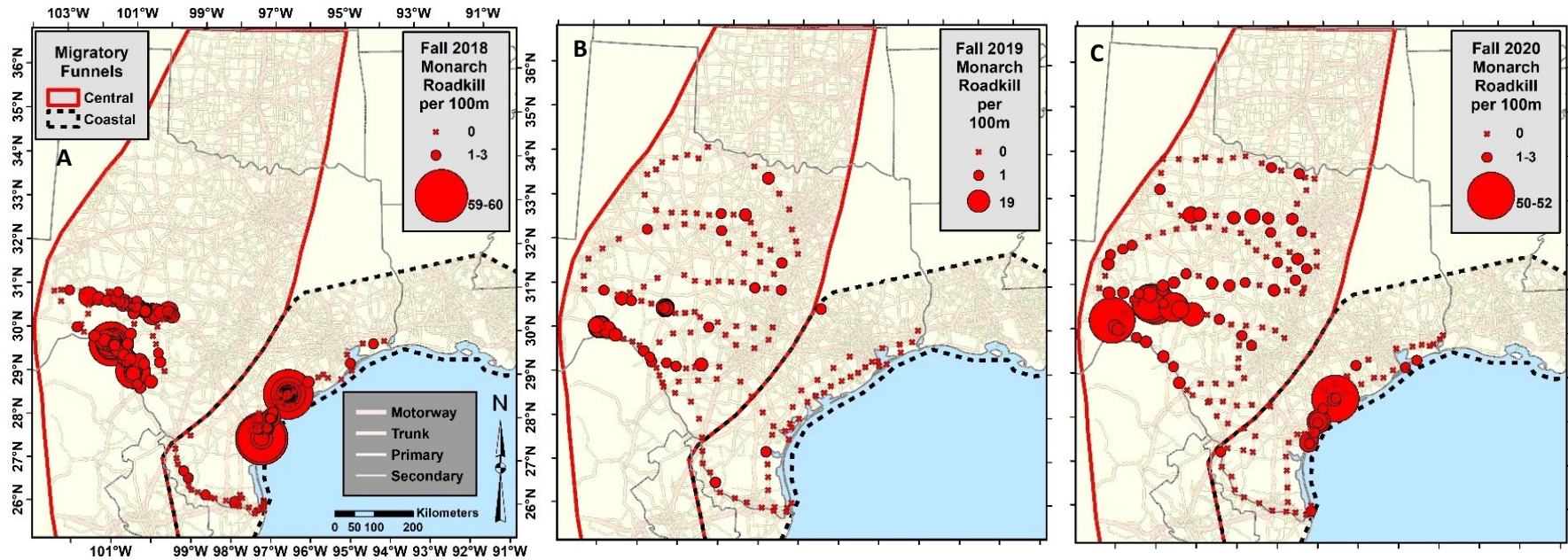
<sup>d</sup>Four presence points was insufficient to model Coastal Funnel roadkill for 2019.



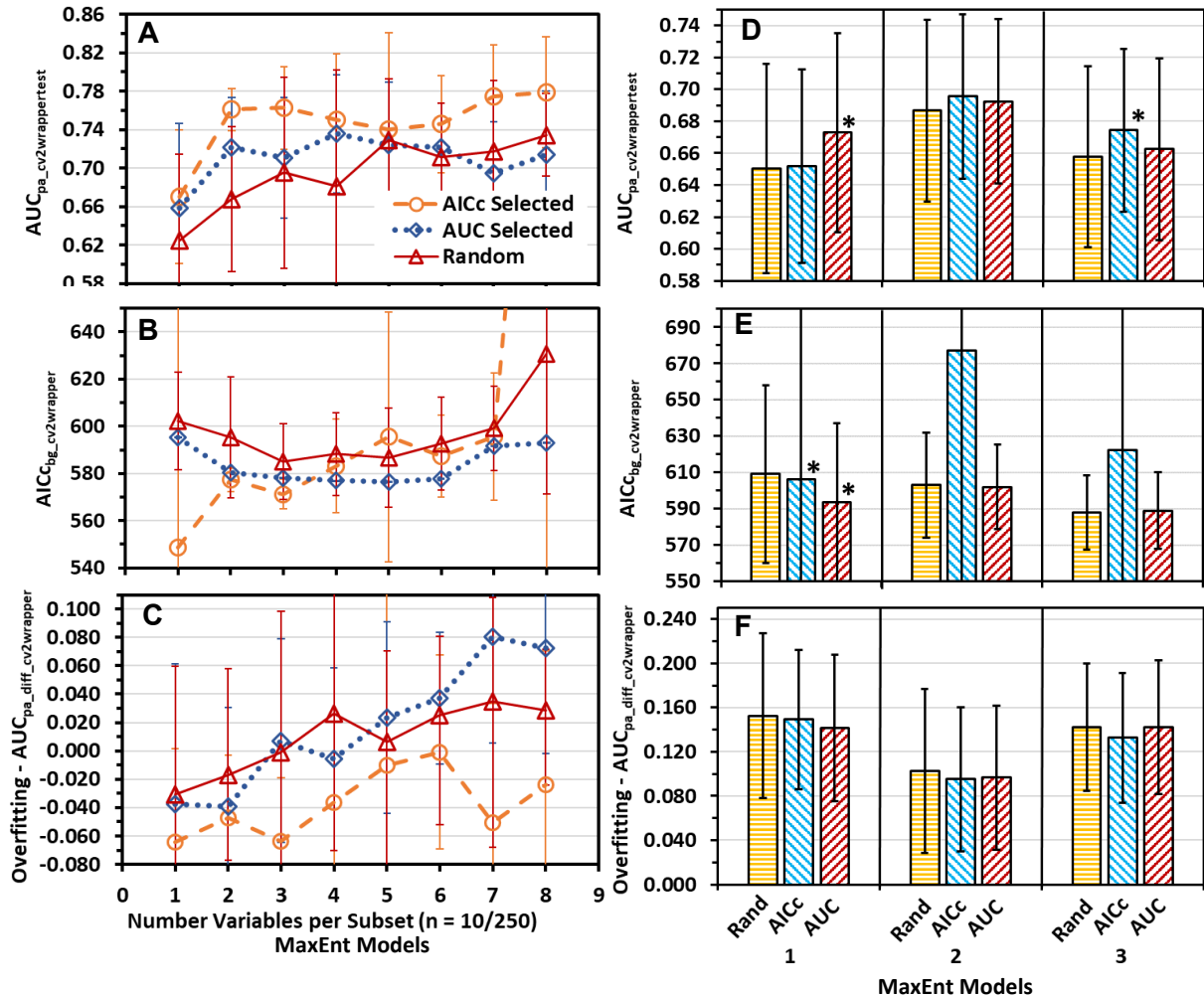
## Figures



**Figure 1. Distribution of Fall 2020 100 x 1 m roadkill transects over Texas roadways within the monarch migratory Central and Coastal funnels (modified from Tracy et al. 2020b Fig. 1).**

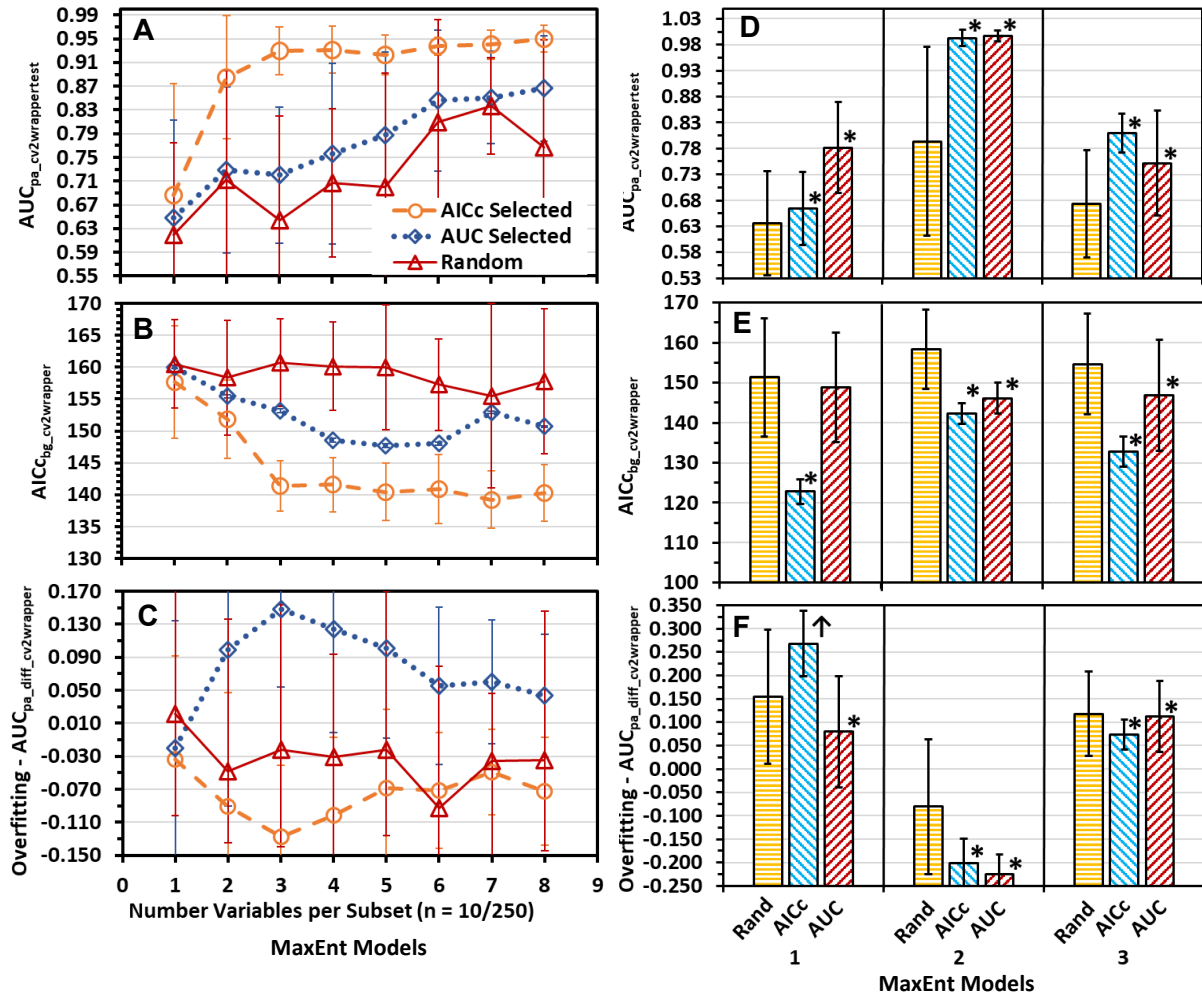


**Figure 2. Spatial distribution of monarch roadkill per 100 m transect (unthinned) during the fall of (A) 2018 (Tracy and Coulson 2019), (B) 2019 (Tracy et al. 2020a) and (C) 2020 (Tracy et al. 2020b) within Texas monarch migratory funnels (scales approximately equivalent across years).**



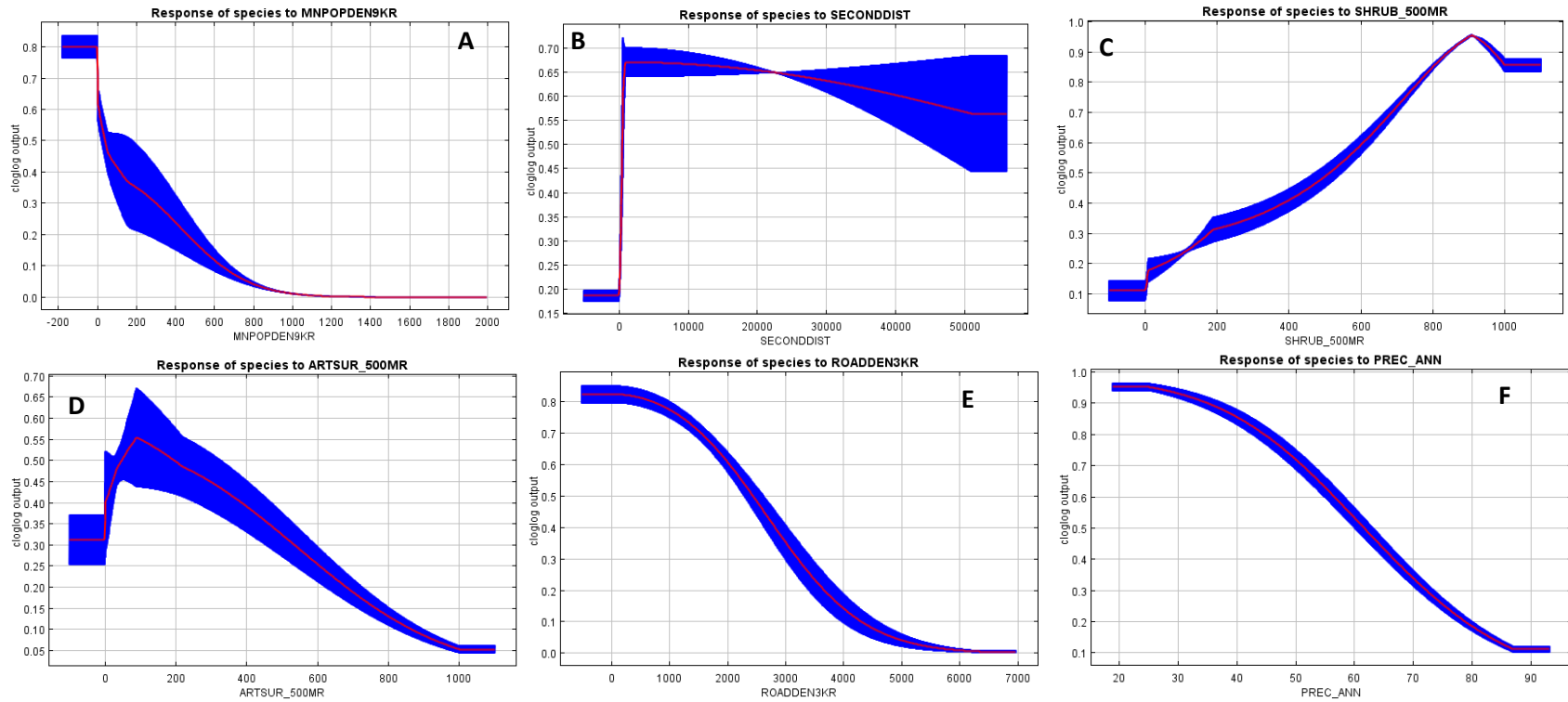
**Figure 3.** Monarch fall 2020 roadkill Central Funnel MaxEnt model evaluation statistics (mean  $\pm$  SD) of  $AUC_{pa\_cv2wrappertest}$  (A,D),  $AICc_{bg\_final}$  (B,E), and  $AUC_{pa\_diff\_cv2wrapper}$  (overfitting; C,F) for models developed from (A-C) top ten variable subsets selected by  $AUC_{pa}$  or AICc using random subset feature selection (RSFSA) and ten random subsets out of 250 randomly generated subsets of various sizes derived from 42 variables; and (D-F) top 250 seven-variable subsets out of 3,150 subsets per three training set replicates selected by  $AUC_{pa}$  or AICc using RSFSA and 297-300 random generated two-variable subsets out of 3,150 subsets derived from 42 variables. Means for  $AUC_{pa}$  selected or AICc selected model statistics within a replicate with an asterisk are significantly more optimal (higher for  $AUC_{pa\_cv2wrappertest}$  and lower for  $AICc_{bg\_final}$  and  $AUC_{pa\_diff\_cv2wrapper}$ ) and means with an arrow significantly less optimal than mean of random selected models ( $P < 0.05$ ; Welch t test with Holm correction, preceded by significant Welch ANOVA test,  $P < 0.05$ ).



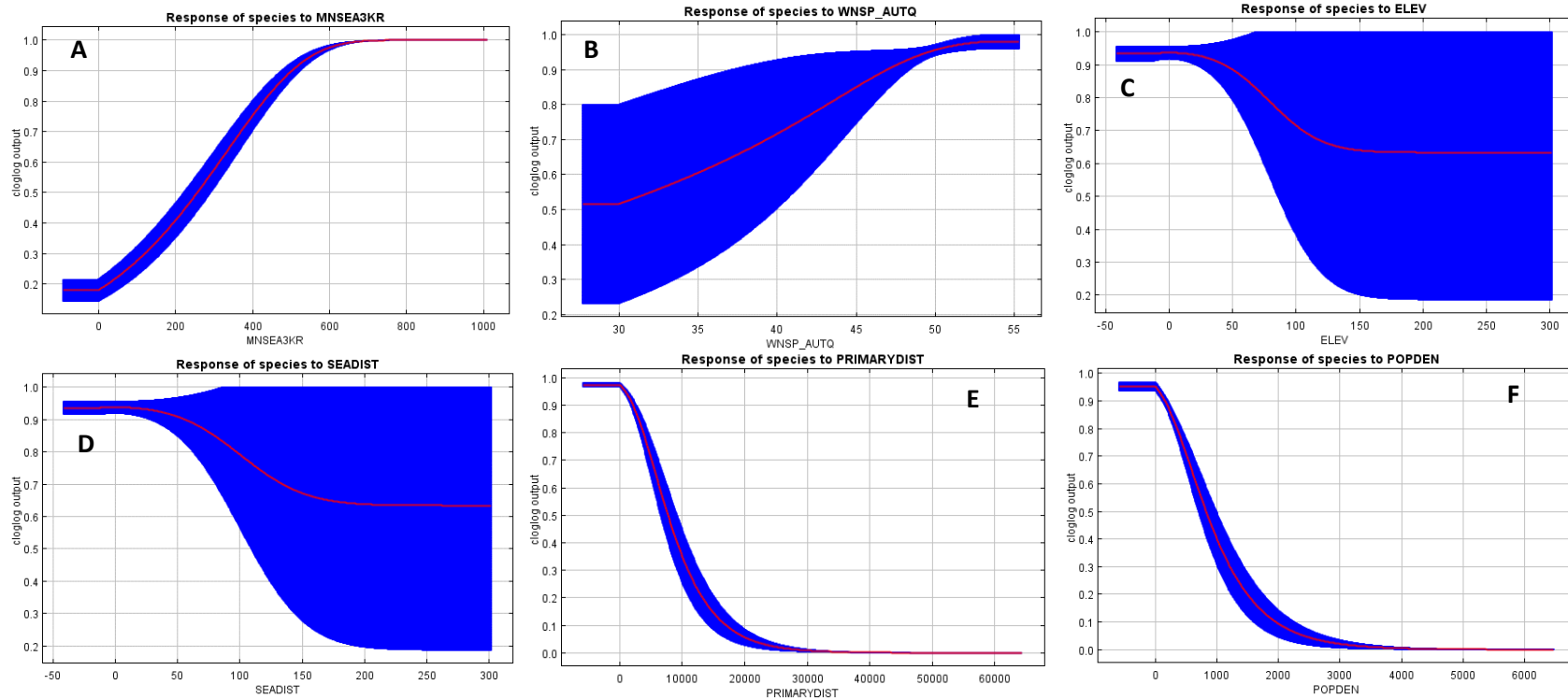


**Figure 4.** Monarch fall 2020 roadkill Coastal Funnel MaxEnt model evaluation statistics (mean  $\pm$  SD) of  $AUC_{pa\_cv2wrappertest}$  (A,D),  $AIC_{bg\_final}$  (B,E), and  $AUC_{pa\_diff\_cv2wrapper}$  (overfitting; C,F) for models developed from (A-C) top ten variable subsets selected by  $AUC_{pa}$  or AICc using random subset feature selection (RSFSA) and ten random subsets out of 250 randomly generated subsets of various sizes derived from 44 variables; and (D-F) top 40-87 three-variable subsets out of 3,150 subsets per three training set replicates selected by  $AUC_{pa}$  or AICc using RSFSA and 86-144 random generated two-variable subsets out of 3,150 subsets derived from 44 variables. Means for  $AUC_{pa}$  selected or AICc selected model statistics within a replicate with an asterisk are significantly more optimal (higher for  $AUC_{pa\_cv2wrappertest}$  and lower for  $AIC_{bg\_final}$  and  $AUC_{pa\_diff\_cv2wrapper}$ ) and means with an arrow significantly less optimal than mean of random selected models ( $P < 0.05$ ; Welch t test with Holm correction, preceded by significant Welch ANOVA test,  $P < 0.05$ ).





**Figure 5. Monarch fall 2020 Central Funnel roadkill MaxEnt model variable response curves for example top ranked variables (Table 2) from top selected seven-variable models: (A) *mnpopden8kr*, (B) *seconddist*, (C) *shrub\_500mr*, (D) *atsur\_500mr*, (E) *roadden3kr*, (F) *prec\_ann* (see Table A1 for variable abbreviations). The curves represent logistic prediction changes as each environmental variable is varied while the other variables are kept at their average sample value.**



**Figure 6. Monarch fall 2020 Coastal Funnel roadkill MaxEnt model variable response curves for example top ranked variables (Table 2) from top selected three-variable models: (A) *mnsea3kr*, (B) *wnsp\_autq*, (C) *elev*, (D) *seadist*, (E) *primarydist*, (F) *popden* (see Table A1 for variable abbreviations). The curves represent logistic prediction changes as each environmental variable is varied while the other variables are kept at their average sample value.**

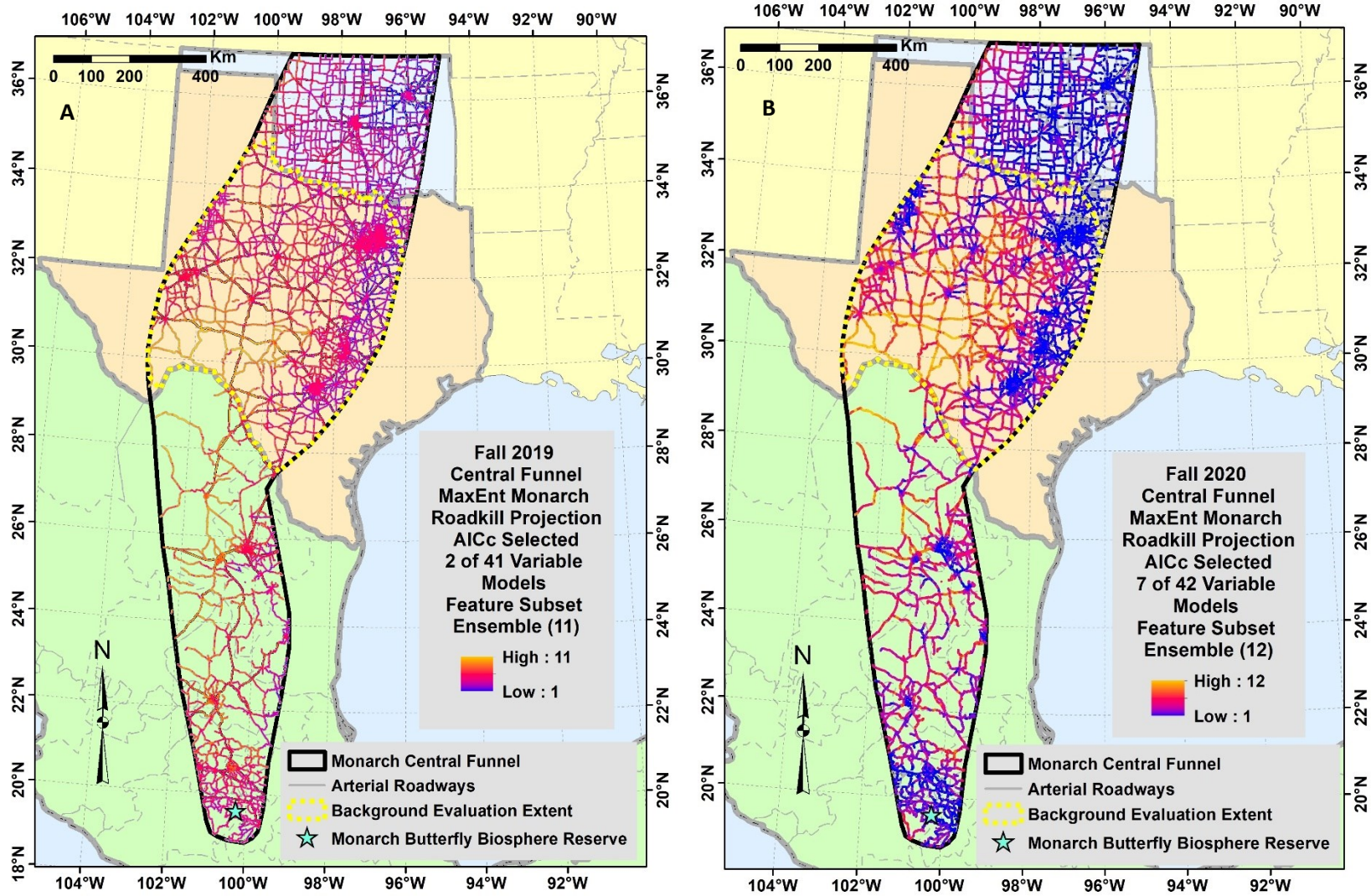


Figure 7. Monarch fall roadkill MaxEnt models in the Central Funnel for (A) 2019 and (B) 2020.



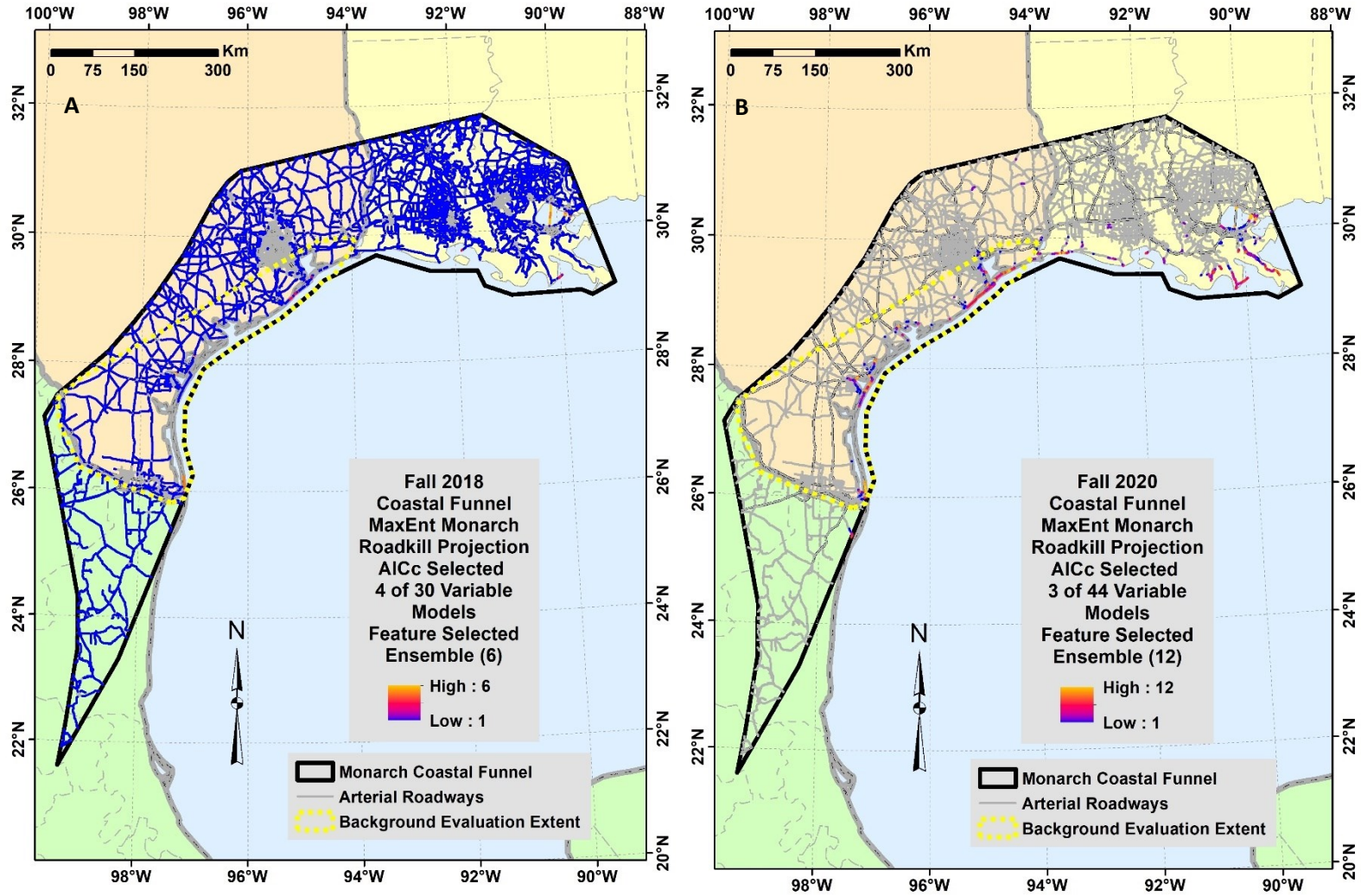
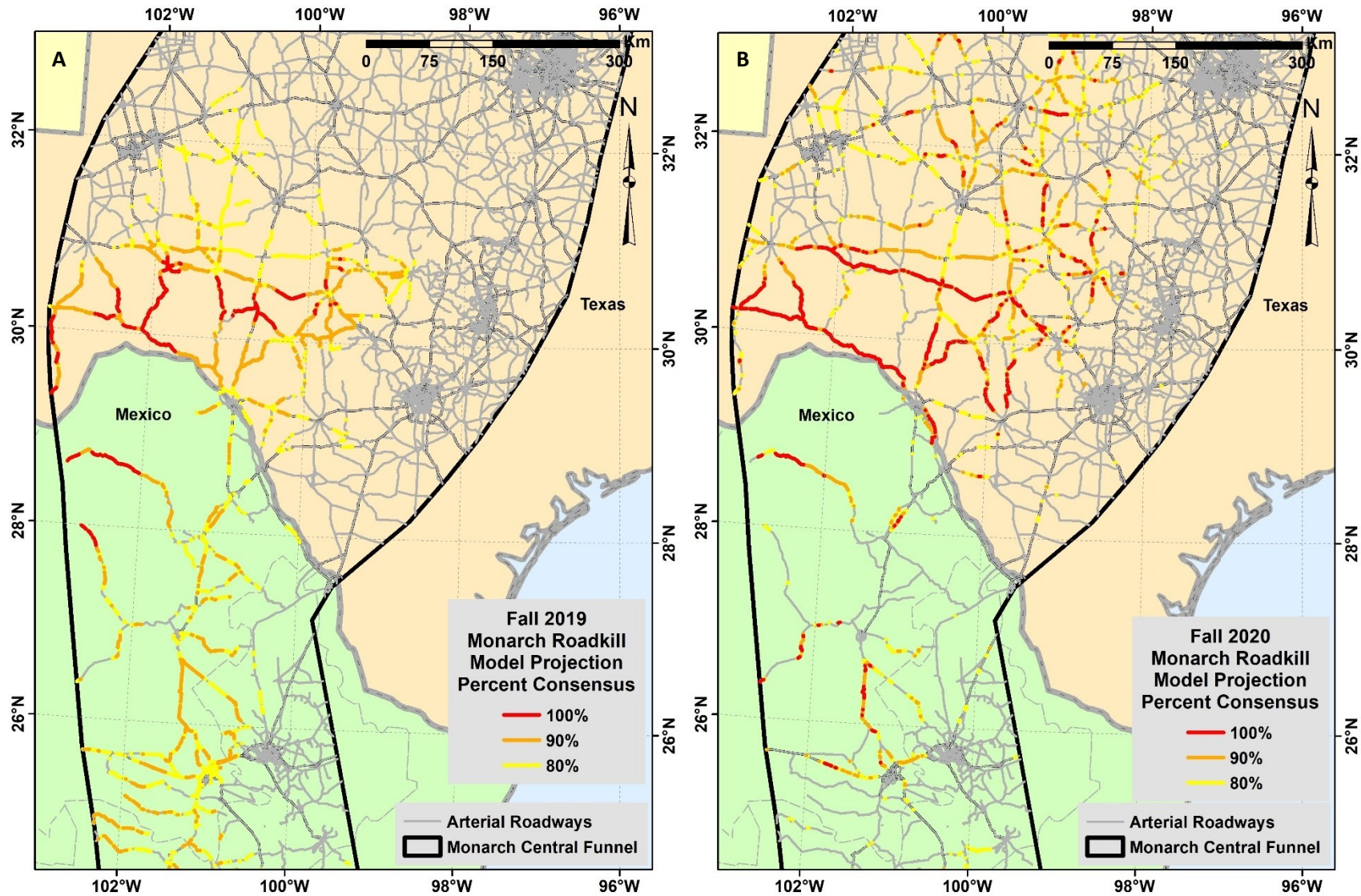
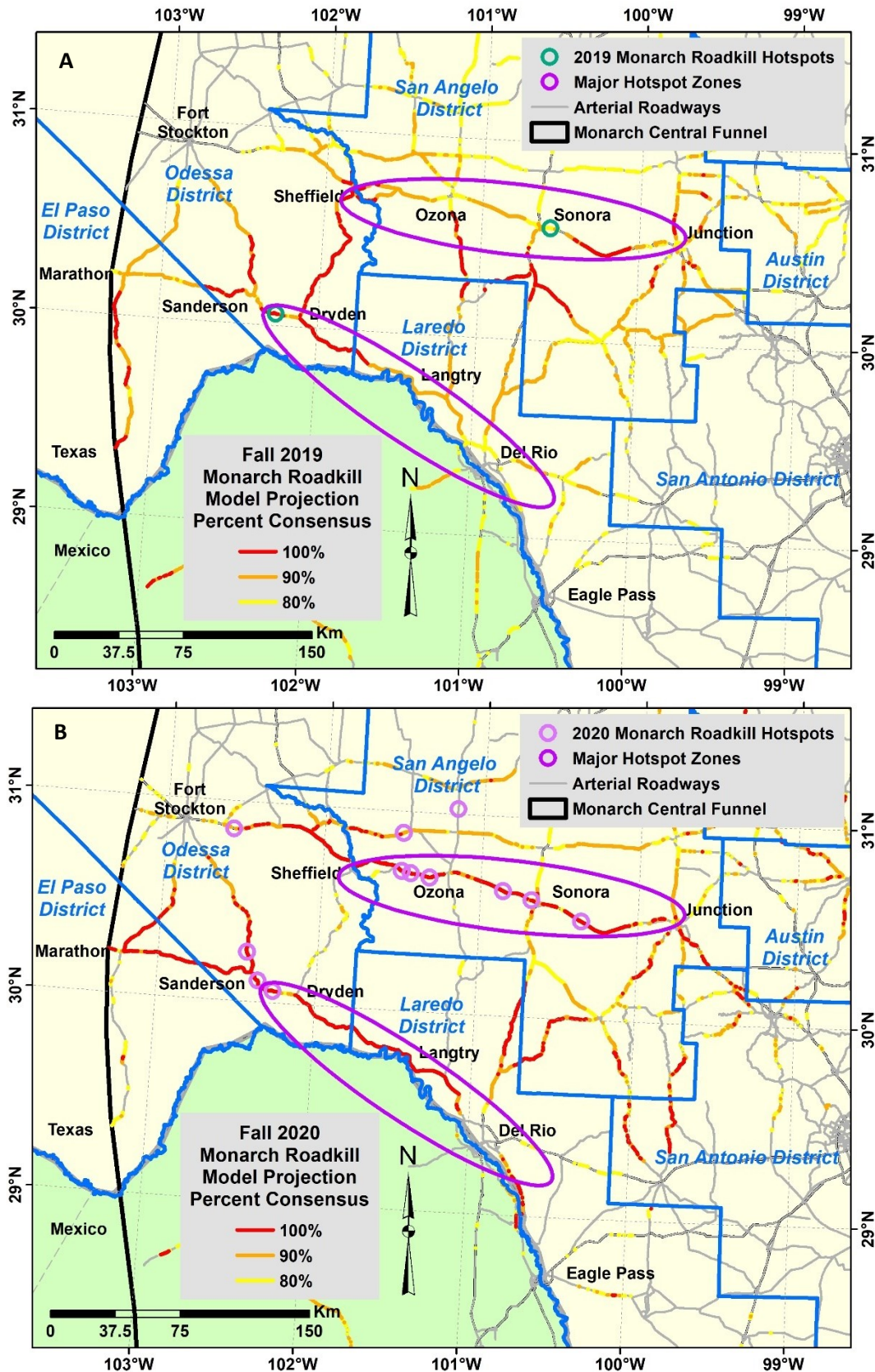


Figure 8. Monarch fall roadkill MaxEnt models in the Coastal Funnel for (A) 2018 and (B) 2020.



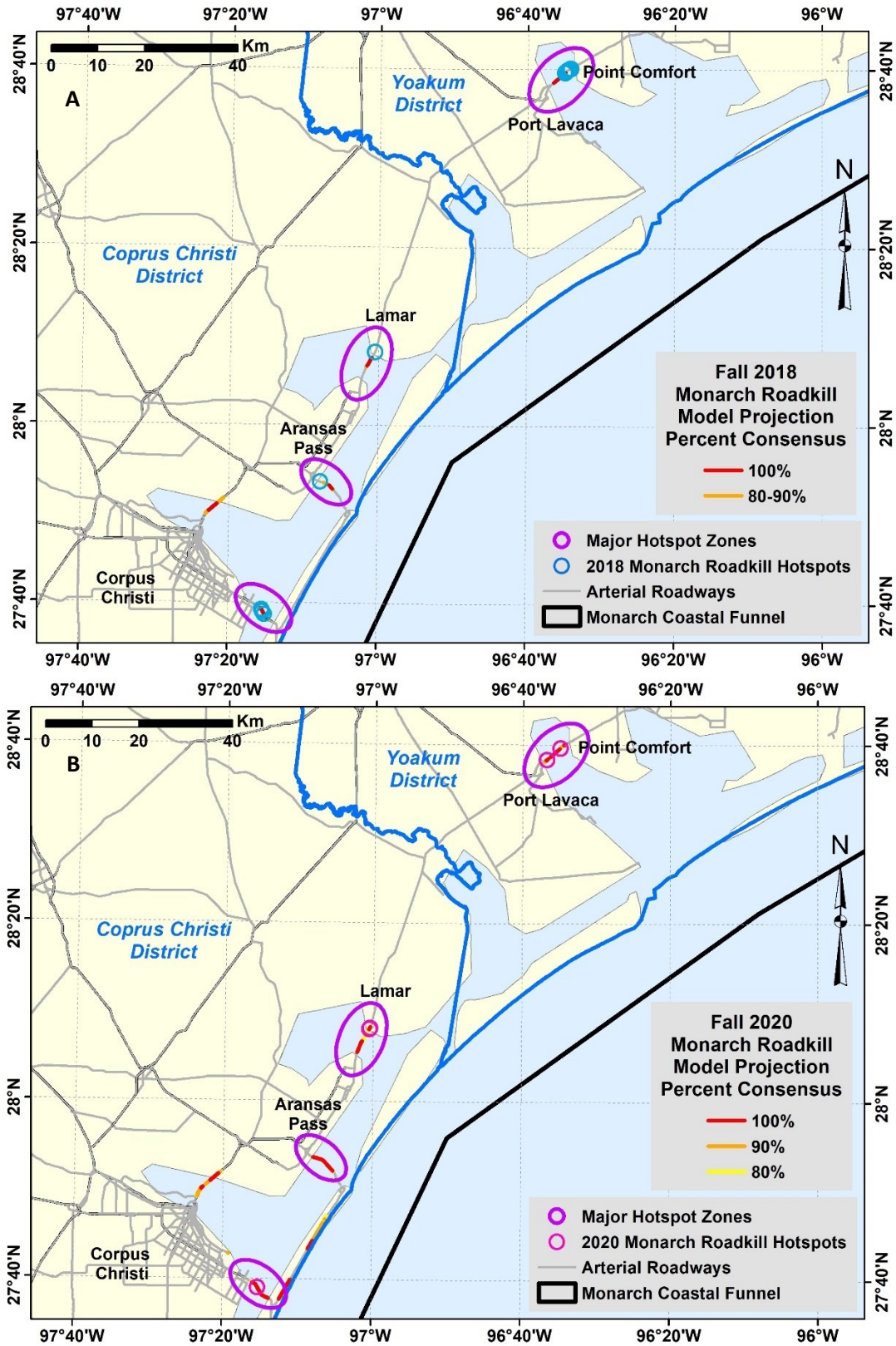


**Figure 9. Monarch fall roadkill in the Central Funnel represented by 80%, 90% and 100% consensus of feature selected MaxEnt models for (A) 2019 and (B) 2020 (Fig. 7).**

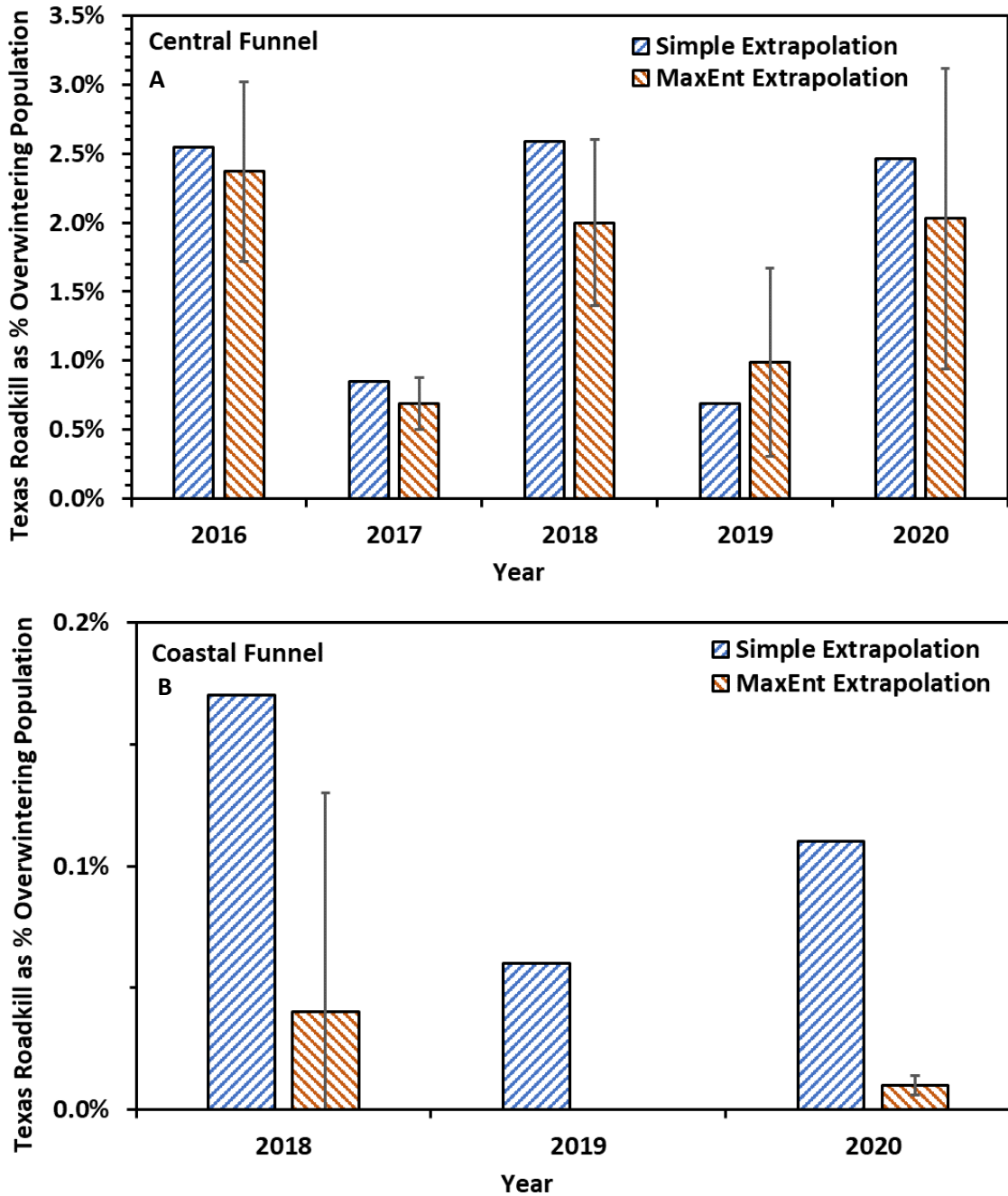


**Figure 10. Monarch roadkill in the Central Funnel represented by 80%, 90% and 100% consensus of feature selected MaxEnt models (Fig. 7) within TxDOT districts for (A) 2019 and (B) 2020.**





**Figure 11. Monarch roadkill in the Coastal Funnel represented by 80%, 90% and 100% consensus of feature selected MaxEnt models (Fig. 8) within TxDOT districts for (A) 2018 and (B) 2020.**



**Figure 12. Monarch roadkill in Texas Central (A) and Coastal (B) migratory funnels from 2016 to 2020 as percentage of overwintering population as calculated by simple extrapolation (Table A4) and MaxEnt model projections (Table 3; see for MaxEnt model sample sizes).**



## References

- Baldwin, M.P., Gray, L.J., Dunkerton, T.J., Hamilton, K., Haynes, P.H., Randel, W.J., Holton, J.R., Alexander, M.J., Hirota, I., Horinouchi, T., Jones, D.B.A. 2001. The quasi-biennial oscillation. *Reviews of Geophysics*, 39:179-229.
- Bellamy, C., Scott, C., Altringham, J. 2013. Multiscale, presence-only habitat suitability models: fine-resolution maps for eight bat species. *Journal of Applied Ecology*, 50:892-901.
- Camargo, S.J., Sobel, A.H. 2010. Revisiting the influence of the quasi-biennial oscillation on tropical cyclone activity. *Journal of Climate*, 23:5810-5825.
- Center for International Earth Science Information Network (CIESIN) - Columbia University. 2016. *Gridded Population of the World, Version 4 (GPWv4): Population Density*. NASA Socioeconomic Data and Applications Center (SEDAC), Palisades, New York, Available at: <http://sedac.ciesin.columbia.edu/data/set/gpw-v4-population-density/data-download>
- Chen, J., Chen, J., Liao, A., Cao, X., Chen, L., Chen, X., He, C., Han, G., Peng, S., Lu, M., Zhang, W. 2015. Global land cover mapping at 30 m resolution: A POK-based operational approach. *ISPRS Journal of Photogrammetry and Remote Sensing*, 103:7-27.
- Evans, J.S., Oakleaf, J., Cushman, S.A., Theobald, D. 2014. *An ArcGIS Toolbox for Surface Gradient and Geomorphometric Modeling, Version 2.0-0*. Available at: <https://www.arcgis.com/home/item.html?id=63ffcecf3b2a45bf99a84cdaedefaccf>
- Fick, S.E., Hijmans, R.J. 2017. WorldClim 2: new 1-km spatial resolution climate surfaces for global land areas. *International Journal of Climatology* 37:4302-4315.
- Geofabrik. 2017. OpenStreetMap Data Extracts. Available at: <http://download.geofabrik.de/>
- Hijmans, R.J., Cameron, S.E., Parra, J.L., Jones, P.G., Jarvis, A. 2005. A very high resolution interpolated climate surfaces for global land areas. *International Journal of Climatology*, 25:1965–1978
- Kantola T., Tracy, J.L., Baum, K.A., Quinn, M.A., Coulson, R.N. 2019. Spatial risk assessment of eastern monarch butterfly road mortality during autumn migration within the southern corridor. *Biological Conservation*, 231:150-160.
- Liu, C., White, M., Newell, G. 2013. Selecting thresholds for the prediction of species occurrence with presence-only data. *Journal of Biogeography*, 40:778–789. <https://doi.org/10.1111/jbi.12058>

- Monarch Watch. 2021. Monarch Population Status. *Monarch Watch Blog*, 25 February 2021. Accessed at <https://monarchwatch.org/blog/2021/02/25/monarch-population-status-45/>
- Mora Alvarez, B.X., Carrera-Treviño, R., and Hobson, K.A. 2019. Mortality of monarch butterflies (*Danaus plexippus*) at two highway crossing "hotspots" during autumn migration in Northeast Mexico. *Frontiers in Ecology and Evolution*, 7: 273.
- NASA Jet Propulsion Laboratory (JPL). 2013. *NASA Shuttle Radar Topography Mission [SRTM] United States 1 Arc Second*. Version 3. 6oS, 69oW. NASA EOSDIS Land Processes DAAC, USGS Earth Resources Observation and Science (EROS) Center, Sioux Falls, South Dakota (<https://lpdaac.usgs.gov>). Available at: <http://dx.doi.org/10.5067/MEaSURES/SRTM/SRTMUS1.003>
- Thogmartin, W.E., Diffendorfer, J.E., López-Hoffman, L., Oberhauser, K., Pleasants, J., Semmens, B.X., Semmens, D., Taylor, O.R., Wiederholt, R. 2017. Density estimates of monarch butterflies overwintering in central Mexico. *PeerJ*, 5:e3221. <https://doi.org/10.7717/peerj.3221>
- Tracy, J.L., Trabucco, A., Lawing, A.M., Giermakowski, J.T., Tchakerian, M., Drus, G.M. and Coulson, R.N. 2018. Random subset feature selection for ecological niche models of wildfire activity in Western North America. *Ecological Modelling*, 383: 52-68.
- Tracy, J.L., Kantola, T., Baum, K.A. and Coulson, R.N. 2019. Modeling fall migration pathways and spatially identifying potential migratory hazards for the eastern monarch butterfly. *Landscape Ecology*, 34(2): 443-458.
- Tracy J.L., and Coulson R.N. 2019. *Eastern Monarch Butterfly Fall Migratory Roadkill Distribution and Hotspot Regions within the Coastal and Central Migratory Funnels of Texas*. Texas A&M Department of Entomology/Texas Transportation Institute Project Final Report. TxDOT Environmental Affairs Division, Austin, Texas. 32 pp. Available at: [https://www.dropbox.com/s/an9wuzkyr54xdb0/TTI\\_TAMU%20Texas%20Monarch%20Roadkill%20Fall%202018%20Report.docx?dl=0](https://www.dropbox.com/s/an9wuzkyr54xdb0/TTI_TAMU%20Texas%20Monarch%20Roadkill%20Fall%202018%20Report.docx?dl=0)
- Warren, D.L., Seifert, S.N. 2011. Ecological niche modeling in MaxEnt: the importance of model complexity and the performance of model selection criteria. *Ecological Applications* 21:335–342. <https://doi.org/10.1890/10-1171.1>
- WorldClim. 2017. *WorldClim Version 1*. Available at: <http://www.worldclim.org/version1>
- WorldClim2. 2017. *WorldClim Version 2*. Available at: <http://www.worldclim.org/version1>

## Appendix

**Table A1. Forty-four environmental predictor indices (30.8 m resolution) evaluated for developing monarch roadkill models.**

Variable Index	Abbreviation <sup>a</sup>	Source
<b>Six Road Indices</b> (based on Open Street Map major road types of motoways, trunks, primary roads, and secondary roads)		
Road density, km road in 500 m circular radius (km/0.78 km <sup>2</sup> ) <sup>b</sup>	<i>roadden500mr*</i>	Derived from OpenStreetMap (Geofabrik, 2017)
Road density, km road in 3 km circular radius (km/28 km <sup>2</sup> ) <sup>b</sup>	<i>roadden3kr***</i>	"
Distance to motorways (m)	<i>motorwaydist*</i>	"
Distance to trunks (m)	<i>trunkdist*</i>	"
Distance to primary roads (m)	<i>primarydist***</i>	"
Distance to secondary roads (m)	<i>seconddist*</i>	"
<b>Four Human Population Density Indices</b>		
Human population density per km <sup>2</sup>	<i>popden**</i>	CIESIN (2016)
Human population density per km <sup>2</sup> in 3 km circular radius (population/28 km <sup>2</sup> ) <sup>b</sup>	<i>mnpopden3kr*</i>	Derived from CIESIN (2016)
Human population density per km <sup>2</sup> in 9 km circular radius (population/254.5 km <sup>2</sup> ) <sup>b</sup>	<i>mnpopden9kr*</i>	"
Distance to urban areas ≥ 300 humans per km (km)	<i>hiurbdist</i>	"
<b>Twenty-Two Topographic Indices</b>		
Aspect	<i>aspect*</i>	Derived from 1 arc second resolution SRTM elevation (NASA JPL 2013)
Compound Topographic Index (CTI) <sup>c</sup>	<i>cti***</i>	"
Curvature (standard combination of profile and planform curvature)	<i>curvature*</i>	"
Dissection, 90 m circular radius <sup>c</sup>	<i>diss90mr*</i>	"
Elevation (m)	<i>elev**</i>	NASA JPL (2013)
Elevation Relief Ratio, 30 m circular radius <sup>c</sup>	<i>err30mr***</i>	Derived from 1 arc second resolution SRTM elevation (NASA JPL 2013)

**Table A1. Forty-four environmental predictor indices (30.8 m resolution) evaluated for developing monarch roadkill models.**

Variable Index	Abbreviation <sup>a</sup>	Source
Latitude (decimal degrees × 10,000)	<i>latitude*</i>	
Mean CTI, 500 m circular radius <sup>b</sup>	<i>mncti500mr</i>	"
Mean CTI, 3 km circular radius <sup>b</sup>	<i>mncti3kr***</i>	"
Mean Flow Accumulation, 500 m circular radius <sup>d</sup>	<i>mnfloacc500mr*</i>	"
Mean Flow Accumulation, 3 km circular radius <sup>d</sup>	<i>mnfloacc3kmr</i>	"
Mean Sea Cover, 500 m circular radius <sup>b,e</sup>	<i>mnsea500mr*</i>	"
Mean Sea Cover, 3 km circular radius <sup>b,e</sup>	<i>mnsea3kmr*</i>	"
Mean Slope, 50 m circular radius <sup>b</sup>	<i>mnslope50mr*</i>	"
Mean Slope, 150 m circular radius <sup>b</sup>	<i>mnslope150mr*</i>	"
Sea Distance (m)	<i>seadist**</i>	"
Site Exposure Index (SEI) <sup>c</sup>	<i>sei*</i>	"
Slope	<i>slope*</i>	"
Slope Cosine Aspect Index (SCAI) <sup>c</sup>	<i>scai</i>	"
Topographic Position Index (TPI), 30 m circular radius <sup>b,c</sup>	<i>tpi30mr***</i>	"
TPI, 90 m circular radius <sup>b,c</sup>	<i>tpi90mr*</i>	"
TPI, 300 m circular radius <sup>b,c</sup>	<i>tpi300mr*</i>	"

**Eight 2010 Globeland30 Land Cover Indices (percent cover in 500 m radius window × 1000; area/0.78km<sup>2</sup>)**

Artificial surfaces	<i>artsur_500mr*</i>	Globeland30 (Chen et al. 2015)
Barren lands	<i>bare_500mr***</i>	"
Cultivated land	<i>cult_500m***</i>	"
Forests	<i>forest_500mr*</i>	"
Grasslands	<i>grslnd_500mr*</i>	"
Shrublands	<i>shrub_500mr*</i>	"



**Table A1. Forty-four environmental predictor indices (30.8 m resolution) evaluated for developing monarch roadkill models.**

Variable Index	Abbreviation <sup>a</sup>	Source
Water bodies	<i>water_500mr*</i>	"
Wetland	<i>wetlnd_500mr</i>	"
<b>Four Climatic Indices<sup>f</sup></b>		
Autumn quarterly mean monthly maximum temperature (°Celsius)	<i>tmax_autq**</i>	for 1960–1990 derived from WorldClim (2017) of Hijmans et al. (2005)
Annual mean monthly rainfall (mm)	<i>prec_ann*</i>	"
Autumn quarterly mean monthly actual evapotranspiration/potential evapotranspiration × 1000	<i>etr_t_autq*</i>	"
Autumn mean quarterly wind speed (m/second)	<i>wensp_autq***</i>	for 1970–2000 derived from WorldClim2 (2017) of Fick and Hijmans (2017)

<sup>a</sup> Asterisks indicate variables utilized in feature selected MaxEnt monarch roadkill niche models. One asterisk indicates use in the Central Funnel models (Table A2), two asterisks represent use in the Coastal Funnel models (Table A3), and three asterisks represent use in models for both funnels.

<sup>b</sup> Variables of different scales (radii) can perform differently in niche models (e.g., Bellamy and Altringham 2013).

<sup>c</sup> Calculated using Geomorphometry and Gradient Metrics Toolbox for ArcGIS (Evans et al. 2014).

<sup>d</sup> Flow accumulation for a grid cell is defined by the number of upslope cells from which water can be accumulated, as calculated by ArcGIS software Flow accumulation tool.

<sup>e</sup> Used in Coastal Funnel models only.

<sup>f</sup> Autumn quarter includes October, November, and December.

**Table A2. Monarch fall 2020 Central Funnel MaxEnt roadkill model permutation importance for 12 AICc feature-selected seven-variable models.<sup>a</sup>**

Model Number with Two Environmental Variables (Permutation Importance)					
Model 1	Model 2	Model 3	Model 4	Model 5	Model 6
<i>mnpopden9kr</i> (45.3)	<i>seconddist</i> (46.2)	<i>mnpopden9kr</i> (47.7)	<i>artsur_500mr</i> (31.8)	<i>prec_ann</i> (72.7)	<i>seconddist</i> (60.4)
<i>seconddist</i> (36)	<i>mnpopden9kr</i> (26.6)	<i>etr_tautq</i> (28.3)	<i>seconddist</i> (29.2)	<i>cult_500mr</i> (16.2)	<i>prec_ann</i> (14.4)
<i>cult_500mr</i> (9.7)	<i>shrub_500mr</i> (18.7)	<i>trunkdist</i> (18.1)	<i>cult_500mr</i> (25)	<i>aspect</i> (5.4)	<i>trunkdist</i> (8.6)
<i>wnsp_autq</i> (7.8)	<i>mncti3kr</i> (8.6)	<i>roadden500mr</i> (5.9)	<i>mncti3kr</i> (8.6)	<i>latitude</i> (4.8)	<i>roadden3kr</i> (7.5)
<i>err30mr</i> (0.8)	<i>tpi300mr</i> (0)	<i>tpi300mr</i> (0)	<i>forest_500mr</i> (5.3)	<i>mnfloacc500mr</i> (0.9)	<i>latitude</i> (6)
<i>primarydist</i> (0.3)	<i>tpi30mr</i> (0)	<i>water_500mr</i> (0)	<i>sei</i> (0.1)	<i>wetland_500mr</i> (0)	<i>grslnd_500mr</i> (2.5)
<i>tpi300mr</i> (0.1)	<i>bare_500mr</i> (0)	<i>tpi30mr</i> (0)	<i>wetland_500mr</i> (0)	<i>tpi90mr</i> (0)	<i>diss90mr</i> (0.6)
Model 7	Model 8	Model 9	Model 10	Model 11	Model 12
<i>prec_ann</i> (68.4)	<i>mnpopden3kr</i> (42.6)	<i>motorwaydist</i> (45.9)	<i>shrub_500mr</i> (41.6)	<i>mnpopden3kr</i> (42.3)	<i>mncti3kr</i> (30.5)
<i>cult_500mr</i> (16.4)	<i>shrub_500mr</i> (28.6)	<i>roadden500mr</i> (32.9)	<i>etr_tautq</i> (31.3)	<i>shrub_500mr</i> (35.3)	<i>motorwaydist</i> (25.4)
<i>slope</i> (6.4)	<i>motorwaydist</i> (15)	<i>aspect</i> (7.1)	<i>mnpopden9kr</i> (23.1)	<i>mncti3kr</i> (12.3)	<i>dist</i> (21.6)
<i>latitude</i> (3.5)	<i>primarydist</i> (7.2)	<i>tpi90mr</i> (6.3)	<i>aspect</i> (2.4)	<i>roadden500mr</i> (6.9)	<i>forest_500mr</i> (12.9)
<i>tpi30mr</i> (3.3)	<i>mnslope50mr</i> (3.9)	<i>cti</i> (5.6)	<i>grslnd_500mr</i> (1.6)	<i>latitude</i> (2.9)	<i>mnfloacc500mr</i> (9.1)
<i>mnfloacc3kr</i> (2)	<i>aspect</i> (2.7)	<i>mnslope150mr</i> (2.2)	<i>wetland_500mr</i> (0)	<i>mnslope150mr</i> (0.2)	<i>grslnd_500mr</i> (0.4)
<i>bare_500mr</i> (0)	<i>bare_500mr</i> (0)	<i>scai</i> (0)	<i>curvature</i> (0)	<i>water_500mr</i> (0)	<i>cti</i> (0)

<sup>a</sup>For variable abbreviations, see Table A1. Variables with zero permutation importance not used in model.

**Table A3. Monarch fall 2020 Coastal Funnel MaxEnt roadkill model permutation importance for 12 AICc feature-selected three-variable models.<sup>a</sup>**

Model Number with Two Environmental Variables (Permutation Importance)					
Model 1	Model 2	Model 3	Model 4	Model 5	Model 6
<i>mnsea3kr</i> (91.4)	<i>mnsea500mr</i> (66.7)	<i>mnsea3kr</i> (73.8)	<i>meansea3kr</i> (85.3)	<i>mnsea3kr</i> (99.9)	<i>mncti3kr</i> (44.7)
<i>popden</i> (8.6)	<i>wmsp_autq</i> (33.3)	<i>elev</i> (16.3)	<i>elev</i> (10.2)	<i>bare_500mr</i> (0.1)	<i>primarydist</i> (55.3)
<i>latitude</i> (0)	<i>mnfloacc500mr</i> (0)	<i>roadden3kr</i> (9.9)	<i>mnslope50mr</i> (4.5)	<i>err30mr</i> (0)	<i>err30mr</i> (0)
Model 7	Model 8	Model 9	Model 10	Model 11	Model 12
<i>mnsea3kr</i> (88.6)	<i>mnsea3kr</i> (83.2)	<i>primarydist</i> (59.6)	<i>mncti3kr</i> (63.2)	<i>primarydist</i> (62.8)	<i>mnsea3kr</i> (88.6)
<i>seadist</i> (11.4)	<i>popden</i> (11.3)	<i>mnsea3kr</i> (34.3)	<i>primarydist</i> (36.8)	<i>mnsea3kr</i> (35.2)	<i>cti</i> (11)
<i>tpi30mr</i> (0)	<i>cult_500mr</i> (5.5)	<i>cti</i> (6.1)	<i>tmax_autq</i> (0)	<i>elev</i> (2)	<i>tmax_autq</i> (0)

<sup>a</sup>For variable abbreviations, see Table A1. Variables with zero permutation importance not used in model.

**Table A4. Estimated fall monarch roadkill over portions of migratory funnels in relation to overwintering estimates (Part III Chapter 2).**

Year/ Location	Average Thinned Presence/ Absence Roadkill per 100m <sup>a</sup>	Hotspot Zone Areas <sup>b</sup>	Estimated Roadkill		Hotspot Zone Roadkill as Percent of Total for Texas	Area Monarchs Over- wintering in Mexico (Ha) (Monarch Watch 2021)	Estimated Over- wintering (millions) <sup>d</sup>	Roadkill as Percent Overwintering Population	
			Entire Funnel <sup>c</sup> (millions)	Texas Portion <sup>c</sup> (millions)				Entire Funnel	Texas Portion
<i>Central Funnel</i>									
2016	2.7127	75,691	2.82	1.57	6.15%	2.91	61.401	4.60%	2.55%
2017	0.7737	0	0.81	0.45	0.00%	2.48	52.328	1.54%	0.85%
2018	5.7256	1,370	5.96	3.31	0.05%	6.05	127.655	4.67%	2.59%
2019	0.7091	299	0.74	0.41	0.09%	2.83	59.713	1.24%	0.69%
2020	2.4061	17,898	2.05	1.09	1.64%	2.10	44.31	4.62%	2.46%
<i>Coastal Funnel</i>									
2018	0.7245	4,478	0.41	0.22	2.80%	6.05	127.655	0.32%	0.17%
2019	0.1304	0	0.07	0.04	0.00%	2.83	59.713	0.12%	0.06%
2020	0.2128	1,651	0.10	0.05	3.30%	2.10	44.31	0.23%	0.11%

<sup>a</sup>Data of 2016-2019 for thinned data from Part III Chapter 2. Data from 2020 thinned to 10 km with adventitious transects in potential monarch roadkill hotspots removed.

<sup>b</sup>Hotspot data of 2016-2019 from Table 4 of Part III Chapter 2. Hotspot data of 2020 from Table 4.

<sup>c</sup>Represents 10 x Thinned Presence/Absence Roadkill per 100 m x road lengths in Table 1. Roadkill from hotspot zones are excluded from totals, but are mostly implicitly represented by transect data from hotspots that were included in calculating the average thinned presence/absence roadkill per 100 m.

<sup>d</sup>Hectares monarchs x 21.1 million monarchs/ha, following Thogmartin et al. (2017).



## CHAPTER 5. SPRING TEXAS MONARCH ROADKILL, MILKWEED, AND MONARCH LARVAL KERNEL DENSITY ESTIMATE MODELS

### Summary

Spring 2017 roadside monarch larval and milkweed density data was combined for the first time with corresponding data from spring 2020 and 2021 and monarch roadkill density from the three years to reveal annual variability and overall patterns in Texas roadside monarch resources. Kernel density estimate surface models of monarch roadkill and roadside monarch larvae and milkweeds highlighted regions with roadside areas of high potential value for spring migrating monarchs, as well as potential gaps in spring monarch migratory connectivity. There was high annual variability in densities of monarch roadkill and monarch larvae, and milkweeds. High monarch larval densities in Northeast Texas, despite low regional densities of monarch-selected land covers, may indicate especially high values of roadsides to monarchs in the Northeast. Overall combined years, valuable roadside areas for monarchs were identified in the northeastern Central Funnel, the northern Coastal Funnel, and Northeast Texas. Roadsides in Northeast Texas appear especially valuable for monarch and milkweed resources compared to the surrounding land covers. Potential locations for seven roadside milkweed Specialized Management Areas were identified throughout Texas. The locations were mainly in high monarch value roadside areas of the Central Funnel and included the Coastal Funnel and Northeast Texas. Specialized management areas included some locations with regionally low roadside monarch value sites and some with higher fall value milkweeds to increase migratory connectivity in Texas for spring and fall migrating monarchs.

### Methods

#### *Monarch Roadkill, Monarch Larval, and Milkweed Observations*

Data on spring 2020 and 2021 monarch roadkill, roadside monarch larvae, and roadside milkweeds were described in Part II Chapters 3 and 5). Similar data was collected in spring 2017 by Kantola et al. (2019), but only the monarch roadkill data were analyzed and reported. The associated unpublished spring 2017 roadside monarch larval and milkweed data is first analyzed and reported in this study. Raw data on densities and distributions are mapped separately for each of the three years 2017, 2020, and 2021 to reveal yearly variability and overall combined year patterns. Larval densities per milkweed plant are mapped in contrast to larvae per transect mapped in 2020 (Part II Chapter 3) and larval densities per hectare mapped in 2021 (Part II Chapter 5).

## *Kernel Density Estimate Surface Models*

The density data on monarch roadkill and roadside monarch larvae and milkweeds were combined over the three years for developing KDE surface models. ArcGIS shapefiles of unthinned density data (including zero values) were converted to North America Albers Equal Area Conic projection before processing with the ArcGIS kernel density tool. The kernel density tool output values were set to “expected counts” using the “geodesic” method. Zero values were omitted from the KDE surface models for mapping, and summary maps included the 85% KDE isopleths.

## *Potential Roadside Milkweed Specialized Management Areas*

Data from the above density distributions and KDE models indicating spring monarch roadside activity and milkweed density were used to prioritize potential sites for roadside milkweed Specialized Management Areas (SMAs; see Part I Chapter 9). These potential SMAs would include spring and fall season plantings of milkweeds and monarch-preferred nectar plants (Part I Chapter 9). A requirement for selecting a potential SMA site was having a wide enough right-of-way (ROW) and shoulder to accommodate a 40 ft wide marked SMA nectar plant transplanting zone within the ROW outside of the 30 ft clear zone from the roadway/shoulder boundary.

## **Results and Discussion**

### *Monarch Roadkill*

Spring monarch roadkill was only detected at two sites in the Central Funnel in 2017 (Fig. 1A). In spring 2020, we detected monarch roadkill at 10 sites throughout the Central Funnel, four sites in the eastern Coastal Funnel, and a single site in Northeast Texas (Fig. 1B). In spring 2021, there were 25 more widely distributed monarch roadkill sites, with 10 sites in the eastern Central Funnel, 12 sites throughout the Coastal Funnel, and three sites in the southern portion of Northeast Texas (Fig. 1C). Combining all three years reveals the broad area over which spring monarch roadkill occurs (Fig. 1D). The combined spring monarch roadkill KDE model highlights several areas of higher roadkill intensity along the east-central portion of the Central Funnel, the central-coastal region of the Coastal Funnel, and the southern tip of Northeast Texas (Fig. 1E).

### *Roadside Monarch Larvae*

The highest spring 2017 monarch larval density per milkweed plant was mostly localized in Northeast Texas, with some high densities in the northern Central Funnel (Fig. 2A). High values for spring 2020 monarch larval density were more broadly distributed with several points in the southeastern Central Funnel and the southern portion of Northeast Texas and a point in the Coastal Funnel (Fig. 2B). High larval densities were more scattered in spring 2021, with points reaching the highest densities of all three years in

the northern and southern edges of the Central Funnel and southern Northeast Texas (Fig. 2C). Larval densities combined across three years are broadly distributed in the eastern portion of the Central Funnel and Northeast Texas (Fig. 2D). Overall, there was high annual variability in the location of high monarch larval densities, with Northeast Texas being one of the more consistent regions for high densities. The KDE model for larval density indicates particularly concentrated densities in Northeast Texas (Fig. 2E), which is unexpected since land cover in Northeast Texas exhibits relatively low selectivity for the major milkweed species compared to the eastern Central Funnel and portions of the central Coastal Funnel (Fig. 3) (Tracy et al. 2022). Relatively high larval roadside densities in Northeast Texas may indicate that roadsides in this region are a particularly important resource for milkweeds and monarch larvae relative to the surrounding predominant land covers.

### *Roadside Milkweeds*

The highest densities of spring 2017 roadside milkweeds were concentrated in the northeastern Central Funnel and northern Northeast Texas (Fig. 4A). High roadside milkweed densities were more broadly distributed in the spring of 2020 and 2021 across the eastern Central Funnel, northern Coastal Funnel, and southern Northeast Texas (Fig. 4C-D). More dense roadside milkweed locations in the southern Coastal Funnel occurred in spring 2021 relative to spring 2020 (this area was not surveyed in spring 2017) (Fig. 4D). High-density regions of roadside milkweeds for the three spring years combined included the northeastern Central Funnel, Northeast Texas, and the northern Coastal Funnel (Fig. 4D). The KDE model for roadside milkweed density was generally more diffuse than for monarch roadkill and monarch larval densities. The highest combined year roadside milkweed KDE densities appeared in the same general broad region of northeastern Texas. The prevalence of high-density milkweeds along roadsides in Northeast Texas was not evident from the milkweed land cover selectivity study of Tracy et al. (2022) (Fig. 3). The 30 m resolution land cover layers used in the land cover selectivity study were too coarse to reveal finer-scale developed, open space roadsides where milkweeds are dense in Northeast Texas.

### *Potential Roadside Milkweed Specialized Management Areas*

Seven potential roadside milkweed Specialized Management Areas (SMAs) were identified on wide ROWs, five of which were associated with spring roadside milkweed hotspots identified in this study (Table 1, Figs. 5-6). Most potential SMAs (locations 1-4; Figs. 5-6) were placed in the Central Funnel where much of the highest density roadside areas for monarch larval and milkweed are located, and this is the largest region of highly selected milkweed land cover (Figs. 3, 5-6). Two SMAs were placed in the Coastal Funnel (locations 5-6) and one in Northeast Texas (location 7) (Figs. 5-6). Regions with relatively low densities of roadside milkweed and monarch larvae (Figs. 2,4,6) and milkweed selected land cover (Fig. 3), such as South Texas, represent potential regional gaps in

spring monarch migratory connectivity. The SMA location 5 was placed in South Texas to enhance monarch spring migratory connectivity (Fig. 6). The seven SMAs were also selected to include all four of the common roadside milkweeds of Texas, with three SMAs dominated by green antelopehorn, two by antelopehorns, one by broadleaf milkweed, and one located in a zizotes milkweed dominated region (Table 1). Both broadleaf milkweed and zizotes milkweed are more important as a late summer and fall monarch generation larval host plant (Tracy et al. 2022), and the SMAs of the western Central Funnel and South Texas would also contribute to fall monarch migratory connectivity.

## Conclusion

Spring monarch roadkill occurs over a broad area of the eastern Central Funnel, the entire Coastal Funnel, and the southern portion of Northeast Texas. The highest monarch roadkill intensities occurred along the northern intersection of the Central and Coastal Funnels and the central coast of Texas. Roadside monarch larval densities had high annual variability and were broadly distributed across the entire Northeast Texas region and the eastern Central Funnel and central Coastal Funnel, with the greatest intensity in southern Northeast Texas. Roadside milkweed densities were heaviest in the northeastern Central Funnel, most of Northeast Texas, and the northern portion and Corpus Christi area of the Coastal Funnel. Much of the regions of highest density monarch roadkill and roadside monarch larvae and milkweeds corresponded well with high-density milkweed selected land covers of the eastern Central Funnel and central Coastal Funnel. Northeast Texas had some of the highest densities of monarch roadkill and roadside monarch larvae and milkweeds, although the density of milkweed selected land covers in this region is low. Roadsides in Northeast Texas may be especially valuable resources for monarch butterflies and milkweeds compared to surrounding land covers. Density data for monarch roadkill and roadside monarch larvae and milkweeds were used to guide the selection of seven potential roadside milkweed SMAs with wide ROWs throughout Texas.



## Tables

**Table 1. Potential Roadside Milkweed Specialized Management Area Locations with Wide Right-of-Ways (ROW).**

Region/Location (TxDOT District)	Latitude	Longitude	Milkweeds <sup>a</sup>	ROW/Shoulder Widths (ft)			
				ROW Width	Shoulder 1	Shoulder 2	ROW Available for Staking <sup>b</sup>
<i>Central Funnel</i>							
#1 - 7 mi East of Thurber, TX on IH- 20W (Forth Worth District)	32.53686	-98.31222	111 antelopehorns, 12 green antelopehorns, and 3 zizotes milkweeds at spring 2021 Transect 4AT18	75	16	9	40
#2 - 6 mi West of Sterling City on TX- 158 (San Angelo District)	31.857407	101.100668	41 broadleaf milkweeds at spring 2020 transect 4AT19	142	10	--	122
#3 - Taylor on US- 79W (Austin District)	30.56152	-97.390733	Common green antelopehorns in ROW from iNaturalist and TxDOT	95	14	--	79
#4 - 3 mi South of Johnson City on US- 281S (Austin District)	30.21764	-98.3799	113 antelopehorns, and 1 zizotes milkweed at spring 2020 transect 2AT17	70	11	--	51
<i>Coastal Funnel</i>							
#5 - Linn on US-69CS (Pharr District)	26.59914	-98.118377	Common roadside zizotes milkweed in region	130	12	--	111
#6 - 2 mi West of Prairie View on US- 290E (Houston District)	30.090181	-96.027828	43 green antelopehorns at spring 2020 transect 3AT28	69	12	--	51

*Northeast Region*

---

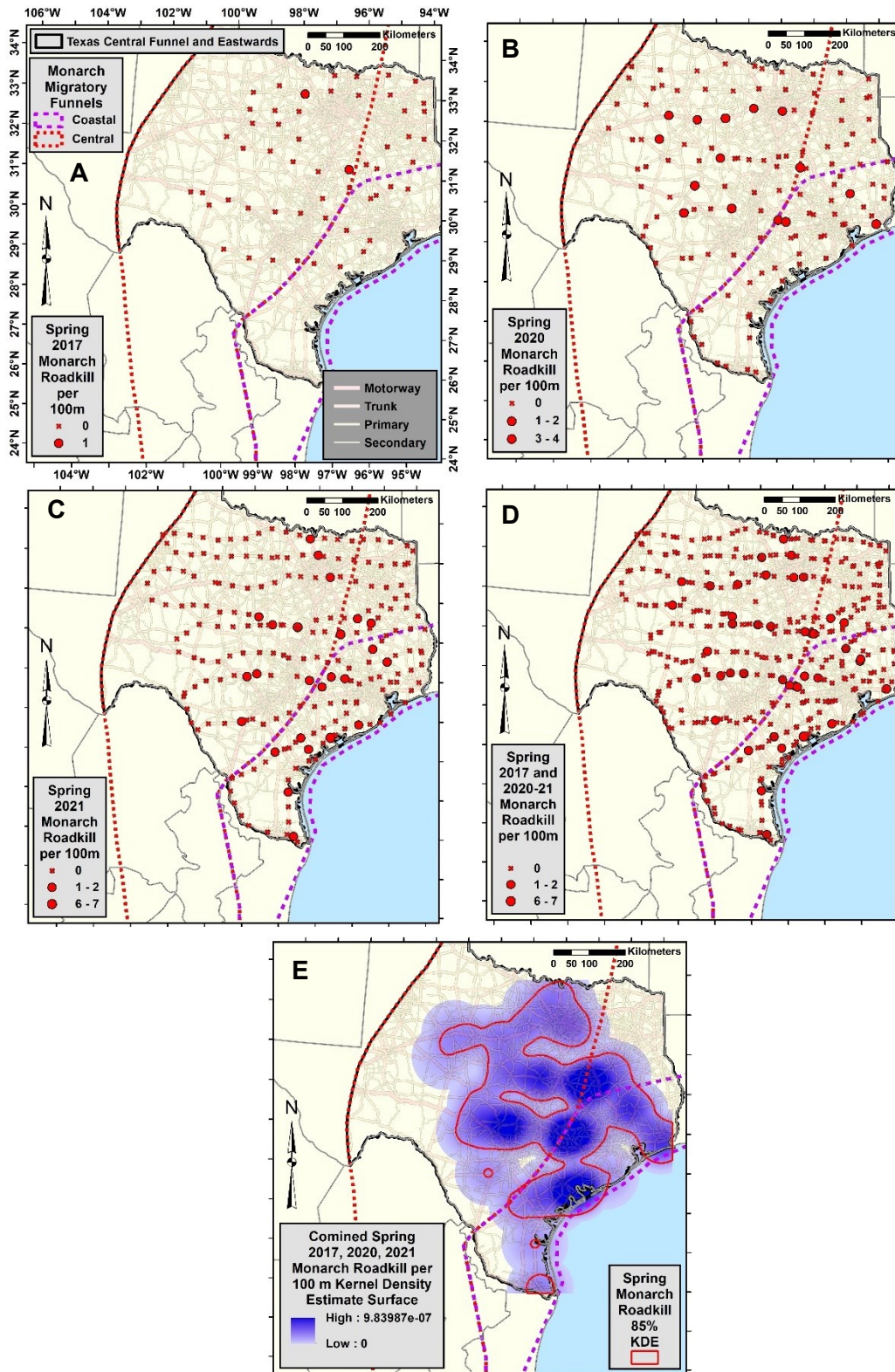
#7 – 10 mi East of							
Sulphur Springs on IH-			250 green antelopehorns at spring				
30W (Paris District)	33.162316	-95.405306	2017 transect T97	317	11	3	271

---

<sup>a</sup>Counted milkweed numbers are per 100 m x 5 m roadside transect.

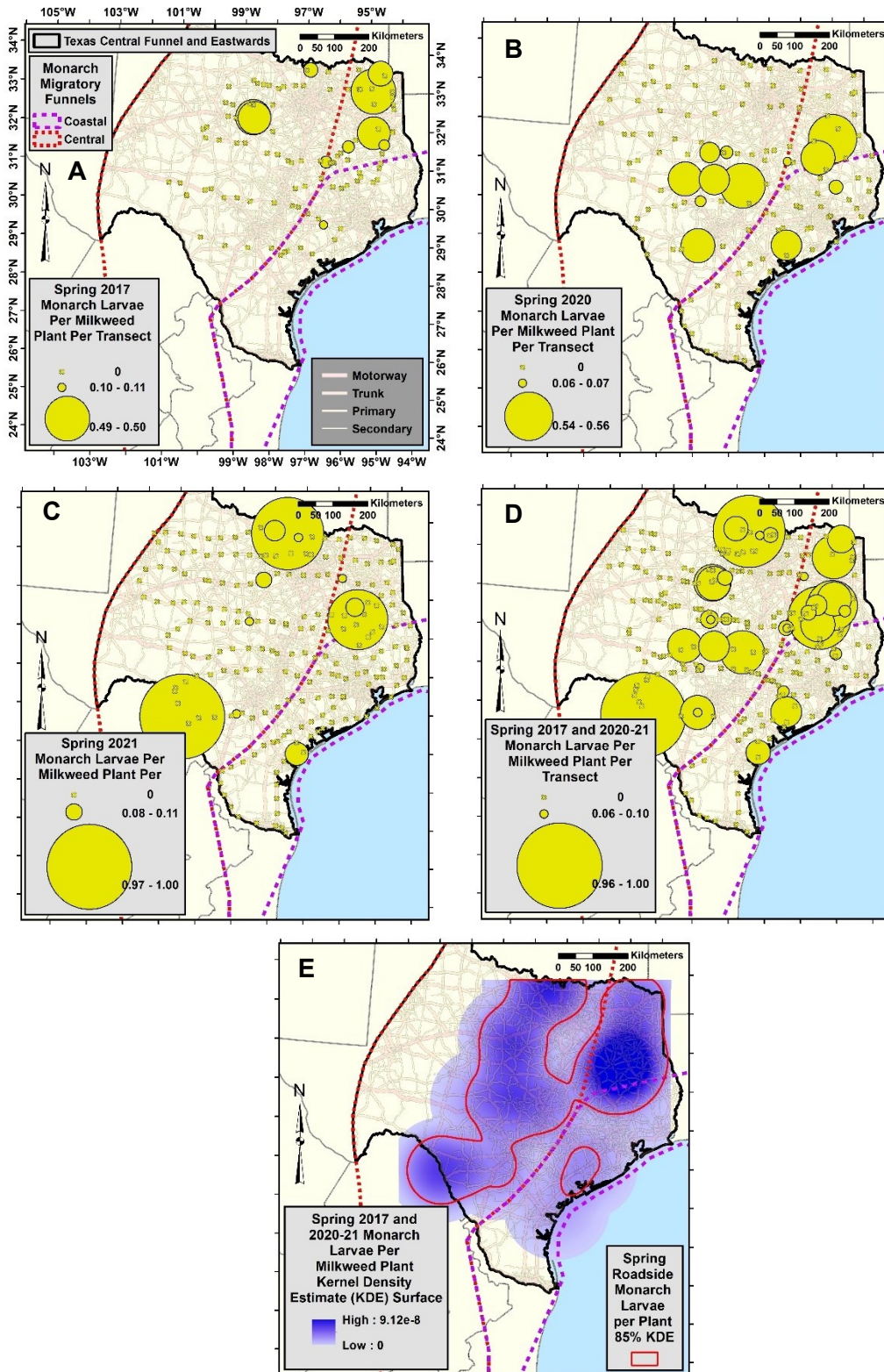
<sup>b</sup>Available ROW calculated by taking the width of a 30 ft clear zone with one shoulder and 60 ft clear zone with two shoulders and subtracting the shoulder width(s) from the clear zone, with the remainder subtracted from the total ROW width. At least 40 ft width available ROW desired for staked Specialized Management Area where milkweeds and monarch-preferred nectar plants are transplanted (see Fig. 5 for locations).

Figures



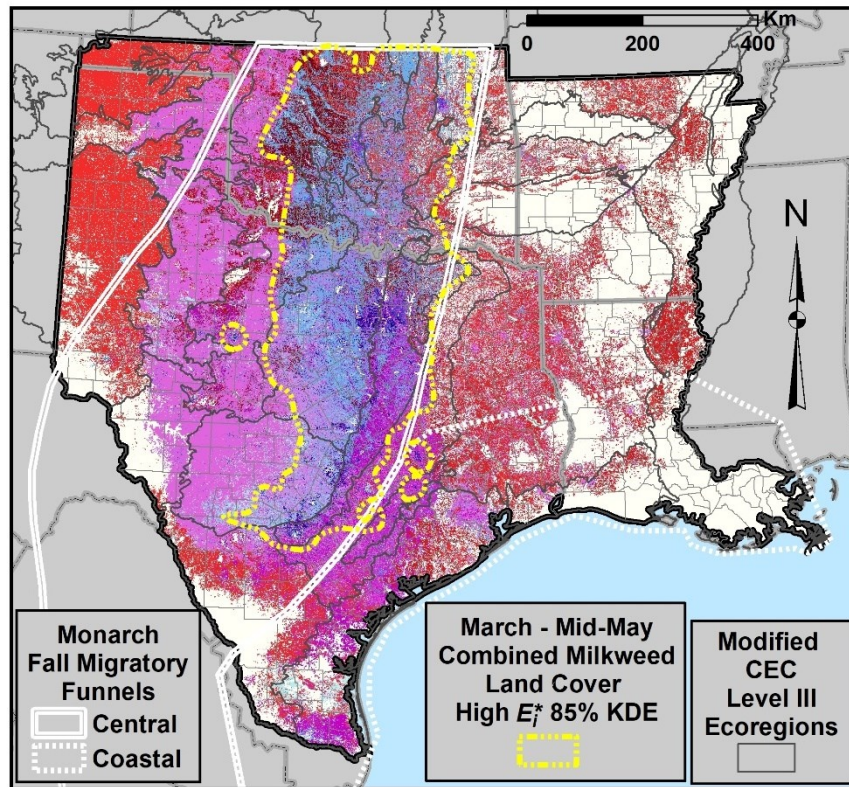
**Figure 1. Distribution of Monarch Roadkill (Unthinned) Per Transect in Texas: (A) spring 2017; (B) Spring 2020 (Tracy et al. 2020); (C) Spring 2021 (Tracy et al. 2021a); (D) Spring 2017, 2020, and 2021 Combined (Symbols CA. Proportional Among Taxa); and (E) Kernel Density Estimate Surface Model of Combined Data (from D).**



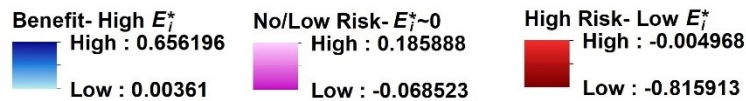


**Figure 2. Distribution of Monarch Larvae Per Milkweed Plant (Unthinned) Per Transect in Texas: (A) Spring 2017; (B) Spring 2020 (Tracy et al. 2020); (C) Spring 2021 (Tracy et al. 2021a); (D) Spring 2017, 2020, and 2021 Combined (Symbols CA. Proportional Among Taxa); and (E) Kernel Density Estimate Surface Model of Combined Data (from D).**

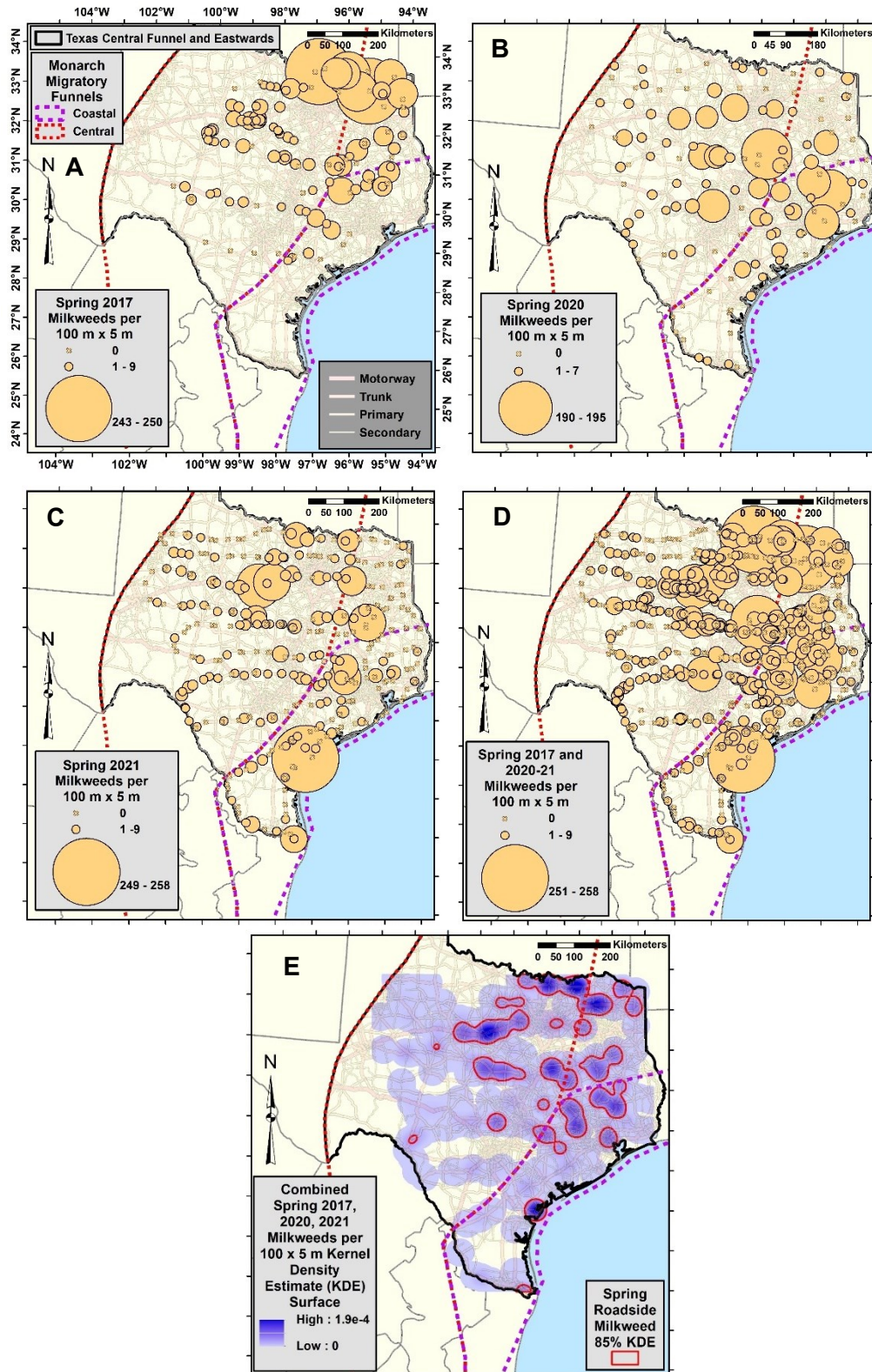




***Asclepias* spp. March - Mid-May Combined  
MaxEnt Core Habitat Land Cover  $E_i^*$**

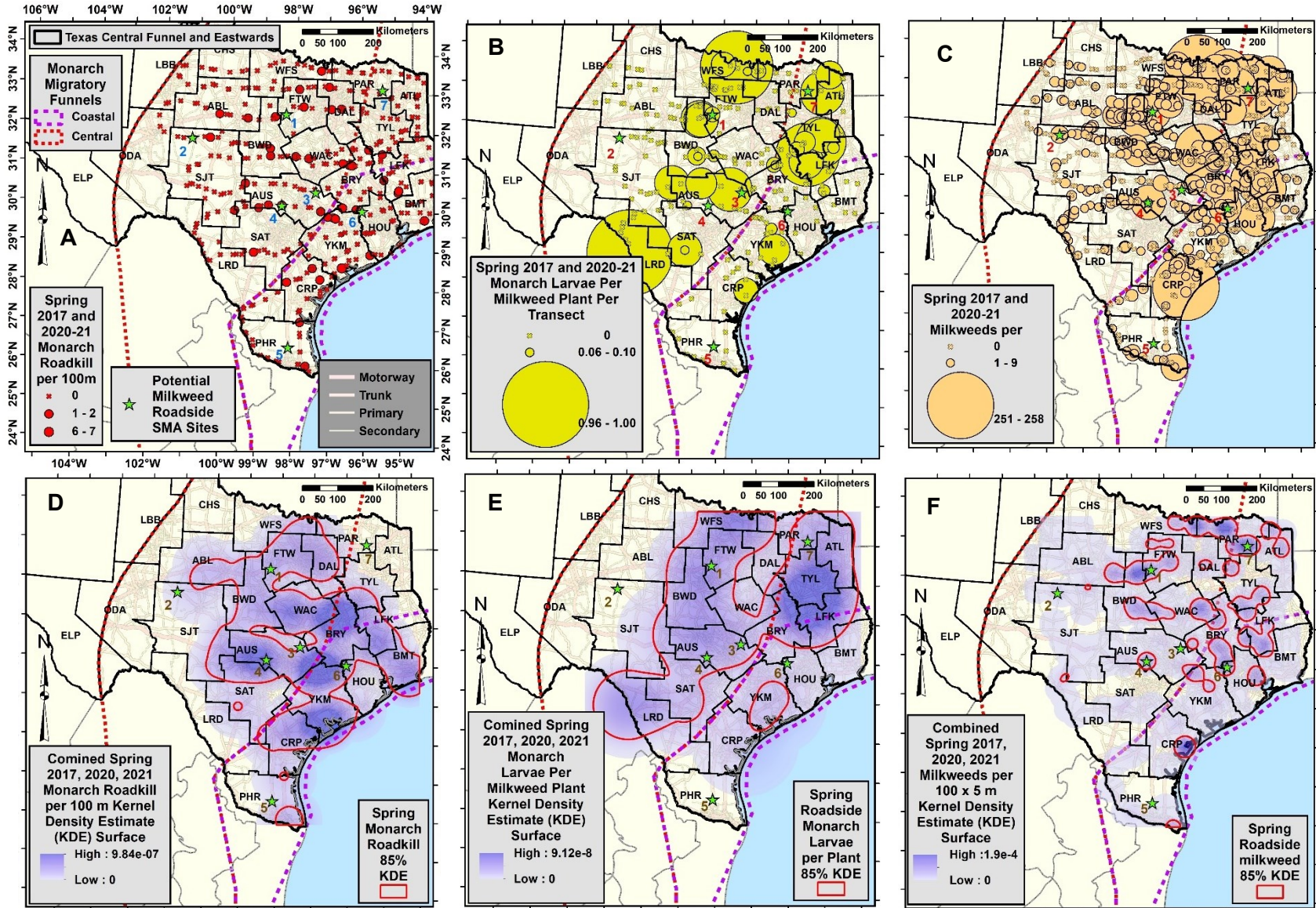


**Figure 3. Combined Milkweed (*Asclepias* spp.) Land Cover Selectivity (2014-2018) for March Through Mid-May According to Land Cover Relativized Electivity Index,  $E_i^*$ , Categories Over MaxEnt Core Habitats and Combined High  $E_i^*$  85% Kernel Density Estimate (KDE) Isopleths (from Tracy et al. 2021c).**



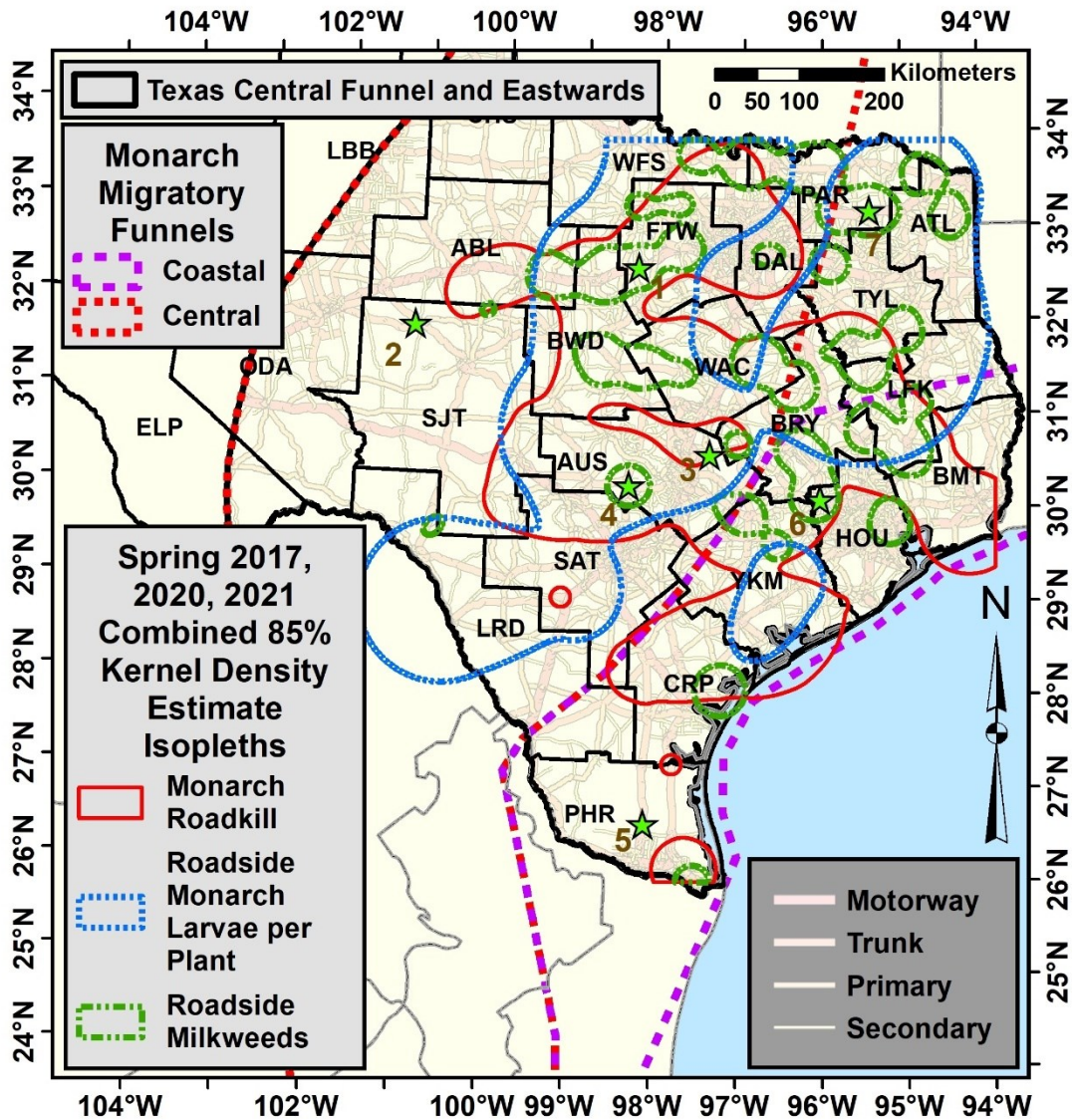
**Figure 4. Distribution of Milkweed Plants (Unthinned) Per Transect in Texas: (A) Spring 2017; (B) Spring 2020 (Tracy et al. 2020); (C) Spring 2021 (Tracy et al. 2021a); (D) Spring 2017, 2020, and 2021 Combined (Symbols CA. Proportional Among Taxa); and (E) Kernel Density Estimate Surface Model of Combined Data (from D).**





**Figure 5. (A-C) Combined Spring 2017, 2020-21 Per Transect Values and (D-F) Kernel Density Estimate Surface Models for Distribution of (A,D) Monarch Roadkill, (B,E) Monarch Larvae Per Milkweed Plant, and (C, F) Milkweeds (from Figs. 1-2, 4). Includes TxDOT Districts and Potential Milkweed Specialized Management Area Locations (see Table 1).**





**Figure 6. Kernel Density Estimate Surface Model 85% Isopleths for Distribution of Monarch Roadkill, Monarch Larvae per Milkweed Plant, and Milkweeds (from Figs. 1-2,4). Includes TxDOT Districts and Potential Milkweed Specialized Management Area Locations (see Table 1).**



## References

- Kantola T., Tracy, J.L., Baum, K.A., Quinn, M.A., Coulson, R.N. 2019. Spatial risk assessment of eastern monarch butterfly road mortality during autumn migration within the southern corridor. *Biological Conservation*, 231:150-160.
- Tracy J.L., Kantola T., Baum K.A., Coulson, R.N. 2022. Distribution and phenology of monarch butterfly larvae and their milkweed hosts in the South Central US. *Biodiversity and Conservation*, In review. <https://www.researchsquare.com/article/rs-755161/v2>

## APPENDIX A. MONARCH ROADKILL MODELING GIS LAYER DEVELOPMENT

### Summary

Spatially explicit correlative roadkill niche models using a variety of algorithms are becoming more common place, with 14 of 19 published roadkill niche model studies (74%) appearing in the last three years since 2017. Examples are given for six categories of spatial environmental layers that have been utilized in roadkill niche models, including Road Indices, Human Population Density Indices, Land Cover Indices, Topographic Indices, Climatic Indices, and Species Landscape Ecological Model Indices. Road Indices used in roadkill niche modeling can be further subdivided into five subcategories of Road Classification Indices, Road Characteristic Indices, Traffic Characteristic Indices, Road Infrastructure Indices, and Roadkill Risk Indices. Species Landscape Ecological Model Indices include three subcategories of Habitat Suitability Model Indices, Species Landscape Connectivity Model Indices, and Species Migration and Dispersal Model Indices. Forty-four environmental layers representing five of the six main categories of indices (excluding Species Landscape Ecological Model Indices) have been used in two prior studies using MaxEnt to model monarch butterfly roadkill through the fall southern migratory pathways, including Texas. A total of 46 indices, including two additional Road Indices not used in previous studies, were selected for developing further models of monarch fall roadkill. In addition to environmental layers available from previous studies, new layers are produced for Land Cover, Climatic, and Topographic Latitude Indices for the Coastal Funnel monarch fall migratory pathway. New Road Indices are also produced over wider areas of both the Central and Coastal fall monarch migratory pathways, including indices of total traffic volume (total average annual daily traffic, total AADT), traffic classification (truck AADT), and traffic speed (speed limits). Well-developed polyline layers for these road indices were available for the United States, but speed limit data was missing from many road segments and will require further interpolation. Traffic volume and classification indices from Mexico are only available in a point location format which requires further processing. The progress and methodologies for producing the new environmental layers is summarized.

### Introduction

#### *Roadkill Niche Modeling Methods*

Correlative roadkill niche modeling involves predicting the presence or absence of mortality along rasterized roadway segments based on correlation with environmental characteristics of the roadway or surrounding area. In contrast to non-spatially explicit roadkill models, such as the regression models of Malo et al. (2004) and Kreling et al.

(2019) and the Boosted Regression Trees model of Ascensão et al. (2017), spatially explicit roadkill niche models are used to produce a map predicting levels of roadkill risk (e.g., Grilo et al. 2009, Kantola et al. 2019). Roadkill niche models have been developed using a variety of at least five main methods, including those listed here from 19 publications (14 of which were published since 2017): **(1) Regression Methods**, such as **Binomial General Linear Models (GLMs)** (Ascensão et al. 2019, Fabrizio et al. 2019a, Valerio et al. 2019), including use of **Logistic** (Gomes et al. 2009, Grilo et al. 2009, Bencin et al. 2019, Visintin et al. 2016), **Gaussian** (Santos et al. 2013), and **Poisson** (Visintin et al. 2017, Lin et al. 2019) link function distributions; **(2) Generalized Additive Models (GAMs)** (Roger and Ramp 2009, Fabrizio et al. 2019a); **(3) Ecological Niche Factor Analysis (ENFA)** (Gomes et al. 2009); **(4) Machine Learning Methods**, such as **MaxEnt** (Ha and Schilling 2017; Garrote et al. 2018; Santori et al. 2018; Kantola et al. 2019; Fabrizio et al. 2019a, 2019b; Sillero et al. 2019; Yue et al. 2019; Wright et al. 2020), **Random Forests (RF)**, and **Generalized Boosted Models (GBMs)** (Fabrizio et al. 2019a); and **(5) Multi-Algorithm Ensemble Models** combining several methods (Fabrizio et al. 2019a).

### *Environmental Layers in Roadkill Niche Modeling*

Environmental layers used in roadkill niche modeling can be divided into at least six categories of indices. The first category of **(1) Road Indices** is especially important, and can be subdivided into five subcategories, including: **(i) Road Classification Indices**, such as principle vs minor arterial roads (Visintin et al. 2016; Garrote et al. 2018; Santori et al. 2018; Kantola et al. 2019; Fabrizio et al. 2019a,b; Wright et al. 2020); **(ii) Road Characteristic Indices**, such as road density (Visintin et al. 2016; Ha and Schilling 2017; Kantola et al. 2019; Yue et al. 2019; Fabrizio et al. 2019a,b; Wright et al. 2020), road topography (e.g., transverse road surface to road shoulders profile, Gomes et al. 2009; distance to vegetation from road surface, Grilo et al. 2009), and distance to road curves (Grilo et al. 2009); **(iii) Traffic Characteristic Indices**, such as annual traffic volume (e.g., average annual daily traffic, AADT; Kantola et al. 2019; Visintin et al. 2016, 2017; Garrote et al. 2018; Wright et al. 2020), traffic speed (Visintin et al. 2016, 2017; Garrote et al. 2018), and day versus night traffic volume (Grilo et al. 2009); **(iv) Road Infrastructure Indices**, such as fencing (Gomes et al. 2009), number of wildlife passages (Grilo et al. 2009), and reflectors (Gomes et al. 2009); and **(v) Roadkill Risk Indices** (or roadkill indices), based on roadkill occurrence of species other than target species for the model (Santos et al. 2013; Ascensão et al. 2017, 2019). The remaining five of six major categories of environmental layers used in roadkill models include: **(2) Human Population Density Indices**, such as population density per km or distance to various urban population level regions (Visintin et al. 2016, Ha and Schilling 2017, Santori et al. 2018, Kantola et al. 2019, Fabrizio et al. 2019a, Wright et al. 2020), **(3) Land Cover Indices**, such as area percent cover of woodland versus grassland or vegetation density from Normalized Difference Vegetation Index (NDVI) (Roger and Ramp 2009, Ascensão

et al. 2017, 2019; Ha and Schilling 2017; Garrote et al. 2018; Santori et al. 2018; Fabrizio et al. 2019b, Yue et al. 2019; Wright et al. 2020), **(4) Topographic Indices**, such as elevation, latitude, slope, and distance to rivers (Roger and Ramp 2009, Visintin et al. 2016, Ascensão et al. 2017, Ha and Schilling 2017, Kantola et al. 2019, Fabrizio et al. 2019b, Yue et al. 2019, Wright et al. 2020), **(5) Climatic Indices**, such as seasonal temperature and rainfall (Visintin et al. 2016, Kantola et al. 2019, Wright et al. 2020), and **(6) Species Landscape Ecological Model Indices** derived from various landscape ecological models for the target species in the roadkill model, including **(i) Habitat Suitability Model Indices** (Santos et al. 2013; Visintin et al. 2016, 2017; Lin et al. 2019) or clustering of habitat characteristics (e.g., Roger and Ramp 2009); **(ii) Species Landscape Connectivity Model Indices** projecting the permeability of the landscape to target species movement (Santos et al. 2013, Fabrizio et al. 2019a), and **(iii) Species Migration and Dispersal Model Indices** describing seasonal vagility and movement patterns that can incorporate landscape connectivity (c.f., Carr and Fahrig 2001, Kantola et al. 2019), All of these categories can include many individual environmental layers, especially climate, landcover, and topography.

Additional **Road Indices** variables used in non-spatially explicit roadkill models include (1) **Road Characteristic Indices** of road width (Barrientos and Bolonio 2009, Barthelmeß 2014), road sinuosity (Barthelmeß 2014), and slope of the right of way (Malo et al. 2004, Barrientos and Bolonio 2009); (2) **Roadway infrastructure Indices** of distance to nearest wildlife passages (Clevenger et al. 2003), wildlife warning signs (Malo et al. 2004), distance to underpasses (Malo et al. 2004, Barrientos and Bolonio 2009), presence of crossroads, presence of guardrails (Malo et al. 2004), presence of bridges (Barrientos and Bolonio 2009, Barrientos and de Dios Miranda 2012), and lighting (Kreling et al. 2019); and (3) **Traffic Characteristic Indices** of traffic classification (vehicle type) (Lee et al. 2004, Barrientos and Bolonio 2009) and percentage of no-passing zone (Barrientos and Bolonio 2009, Barrientos and de Dios Miranda 2012). **Temporal Indices** for the time of year are also used in non-spatial models, including season and moon phases (Kreling et al. 2019). Temporal Indices of roadkill were used by Lin et al. (2019) to develop separate seasonal and annual roadkill niche models showing variation in the distribution of road mortality for four reptile species in Taiwan during the spring, summer, and fall seasons. A review by Gunson et al. (2011) provides many additional examples of employing the above-mentioned environmental layers in mostly non-spatially explicit roadkill models.

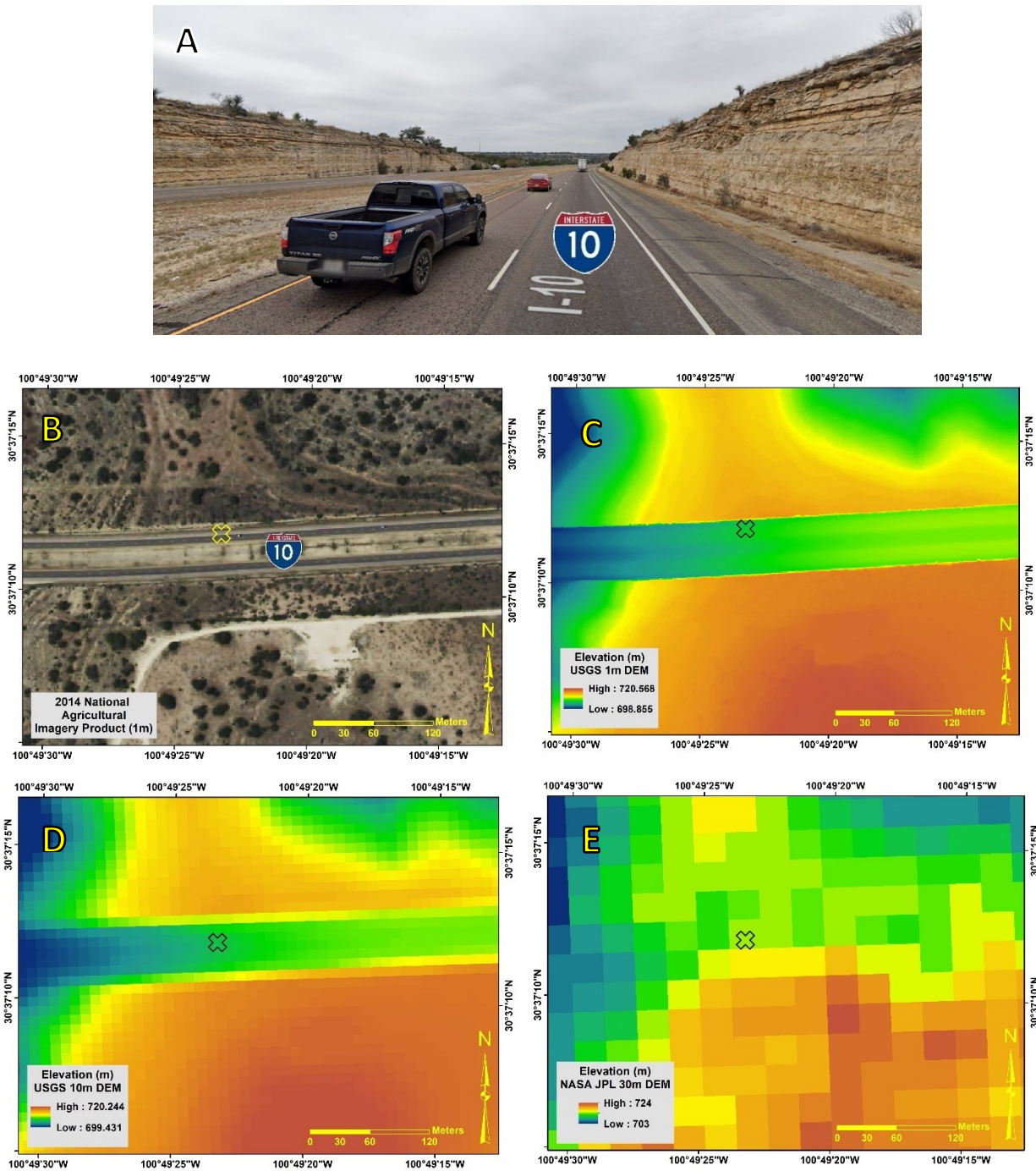
The choice of which of the many potential environmental layers to include in roadkill niche modeling depends upon expert knowledge of what layers may most affect the occurrence and road mortality for a given target species and the availability of the layers at a given spatial resolution (see below).



## *Spatial Resolution of Environmental Layers in Roadkill Modeling*

Two lane roadway surfaces generally occupy a width of about 7 m (Google Earth 2019), but most roadkill modeling studies employ much lower spatial resolutions, such as 1km (e.g., Visintin et al. 2016, Ascensão et al. 2019, Bencin et al. 2019, Fabrizio et al. 2019b, Lin et al. 2019, Sillero et al. 2019), 500m (Gomes et al. 2009, Grilo et al. 2009, Santos et al. 2013), 250m (Santori et al. 2018), 100m (Valerio et al. 2019), 40m (Fabrizio et al. 2019a), 30m (e.g., Ha and Schilling 2017, Kantola et al. 2019, Tracy and Coulson 2019, Yue et al. 2019), and 25m (Roger and Ramp 2009). Wright et al. (2020) developed complementary roadkill niche models at both 1km and 100m resolution for comparison. The selected spatial resolution is usually based on the resolutions of the available roadkill data and environmental layers. As spatial resolution increases to 30m and higher, computer processing time can greatly increase for running roadkill models over large areas, such as entire states or countries.

Many fine scale environmental conditions at less than 30 m resolution can influence the probability of animal crossings and roadkill. For example, extensive deep road cuts (Fig. A.1 A-B) may discourage animals from walking along and into roadways and may divert flight of aerial fauna, such as butterflies, above the traffic. Topographic layers derived from a Digital Elevation Model (DEM) of 1 or 10 meters (Fig. A.1 C-D) can detect such roadcuts much better than more commonly used 30 m DEMs (Fig. A.1E). Spatial resolutions of 10m or less, especially for topographic indices, would probably be useful in roadkill niche models for detecting fine scale roadkill risk. Within the U.S., there is limited availability of 1 m DEMs derived from LIDAR data, with only about half of Texas having coverage, but complete 10 m DEM coverage extends over all states (USGS 2019). On a global basis, only 30m DEMs are available (e.g., NASA JPL 2013). Most environmental layers are generally not available at higher than 30m resolution. For example, across countries, available land cover layers are generally limited to 30m resolution, such as the 2016 NLCD layer (Multi-Resolution Land Characteristics Consortium 2019) for the U.S. and the 2010 Globeland30 (Chen et al. 2015) layer globally. Many environmental layers are only available globally at 1km resolution, including historical climate (WorldClim 2017, WorldClim2 2017) and 2010 human population density (Center for International Earth Science Information Network 2016).



**Figure A.1. Road cut along Interstate Highway 10, 18 km west of Sonora, Texas (A-Google Maps 2019; B-Texas Natural Resources Information System 2019) with digital elevation models (DEMs) at resolutions of 1 (C), 10 (D) (USGS 2019), and 30 (E) (NASA JPL 2013) meters.**

But these 1km layers can be interpolated to provide approximations at higher resolutions such as 30m. Many traffic related layers derived from polyline shapefiles are available at resolutions of less than 10m, such as road classifications from Open Street Map (Geofabrik 2017).

### *Previous Environmental Layers for Monarch Roadkill Modeling*

Kantola et al. (2019) previously utilized 30 environmental layers at 30m resolution for MaxEnt modeling of monarch butterfly roadkill in the Central Funnel migratory pathway from Oklahoma through Texas to Mexico. These 30 layers included five of the six above identified categories of indices, including six road indices, three human population indices, nine topographic indices, eight land cover indices, and four climatic indices. Bellamy and Altringham (2013) demonstrated that area sensitive indices calculated at multiple scales can perform differently in niche modeling, and several indices of road density, topography, and human population density were developed at different scales (area radii) to increase the chances of including more relevant variables. Kantola et al. (2019) found that the two most important variables associated with higher monarch roadkill were arid climate, as evidenced by lower precipitation and lower ratios of actual to potential evapotranspiration, and lower human population density, including greater distances to urban areas and lower road density. Preliminary models of Kantola et al. (2019) that also included traffic volume for Oklahoma and Texas (not available for Mexico), indicated that low traffic volume was an important variable for projecting higher roadkill. These variables reflect the arid, lower population conditions of the southern areas of the Central Funnel where monarch populations become more concentrated as they migrate southwards into Mexico.

Tracy and Coulson (2019) developed models for fall 2018 monarch roadkill in both the Central and Coastal migratory funnels using 30 environmental layers at 30m resolution that differed from Kantola et al. (2019) by having 21 topographic indices, four human population indices, and five road indices, with no indices for climate or land cover. The 19 additional topographic indices were included to better understand the influence of local topography on monarch butterfly roadkill. Similar to the findings of Kantola et al. (2019), important predictors of roadkill in the Central Funnel were found to be indicators of low population density. Higher distance to interstate principal arterial roadways (highways) was an indicator of more roadkill in 2018, which is in contrast to the findings of Kantola et al. (2019) for 2016-2017. This difference resulted from more monarch roadkill found in 2018 on other principal arterial roadways (primary roads) than on interstate principal arterials. The topographic indices at 30m resolution had low importance in the Central Funnel models. Higher resolution topographic layers, such as at 10 m resolution, may be needed to better assess the influence of topography on roadkill in the Central Funnel (Fig. A.1). In contrast to the Central Funnel roadkill models, Tracy and Coulson (2019) found that for the Coastal Funnel, the topographic layer of

mean sea cover in a 3km radius was the most important variable, which was indicative of causeways over bays where most of the monarch roadkill was found.

### *Selected Environmental Layers*

Forty-six environmental layers from five of six index categories were selected for future MaxEnt monarch roadkill modeling of fall 2020 to fall 2021 data, representing a combination of layers used by Kantola et al. (2019) and Tracy and Coulson (2019). These variables include three additional Road Indices in the traffic characteristic indices subcategory, including traffic volume, traffic classification (i.e., traffic volume for trucks), and traffic speed (Table A.1). Thirty-one of these 46 layers were selected for their value in previous monarch roadkill models (asterisked index abbreviations in Table A.1). Environmental layers were selected from most of the categories used in other roadkill niche models discussed above, but several were excluded that were not considered as important for roadkill of migrating butterflies. For example, certain roadway characteristic indices, such as road topography, road width, and road sinuosity, probably have little influence on monarch roadkill in the study area. Similarly, a variety of roadway infrastructure indices, such as lighting, fencing, bridges, and wildlife crossings (non-existent) probably have little bearing on roadkill of day flying migrating monarchs. Tracy et al. (2019) found that correlative habitat suitability models for fall migrating monarchs had limited utility in projecting monarch migratory pathways, especially through desert areas, and these would probably not contribute to roadkill models. Kernel density estimate models of monarch migratory pathways developed by Tracy et al. (2019) were incorporated in defining the study areas over which to develop the roadkill models.

The spatial resolution of 30m for environmental layers in the MaxEnt modeling was maintained to match with available Globeland30 land cover layers and previous studies (Kantola et al. 2019, Tracy and Coulson 2019). Additional MaxEnt roadkill models at a finer 10m resolution (Fig. A.1D) will be considered for application over a limited area of the Central Funnel in Texas to better assess the influence of local topography on roadkill while limiting the amount of computer processing time required with the finer resolution. These finer scale models will require additional interpolation of 1km climate and human population layers and 30m land cover layers to 10m resolution.

The random subset feature selection algorithm (RSFSA) of Tracy et al. (2018) will be used to select smaller subsets of the 46 variables that produce higher performing MaxEnt roadkill niche models. Tracy and Coulson (2019) developed the modified cross-validated version of RSFSA, RSFSA-CV, that can be used with smaller sets of data more typical of roadkill studies. The remaining three chapters detail the methods and progress towards preparing the 30m resolution layers for use in the MaxEnt roadkill models.



**Table A.1 Forty-six environmental predictor indices (30.8 m resolution) evaluated for developing monarch roadkill niche models.**

Variable Index (Number per Category)	Abbreviation <sup>a</sup>	Source
<b>Road Indices (8)</b> - Based on arterials in the USDOT-FHWA (2013) highway function classification system (< 10 m resolution)		
<i>Road Classification Indices (3)</i>		
Distance to interstate and other freeways and expressway principal arterials (OSM highways, motorways and trunks) (m)	<i>highwaydist*</i>	Derived from OpenStreetMap (OSM) (Geofabrik, 2017)
Distance to other principal arterials (OSM primary roads) (m)	<i>primrddist*</i>	"
Distance to minor arterials (OSM secondary roads) (m)	<i>secrddist</i>	"
<i>Road Characteristic Indices (2)</i>		
Road density, km road in 500 m circular radius (km/0.78 km <sup>2</sup> )	<i>roadden500mr*</i>	"
Road density, km road in 3 km circular radius (km/28 km <sup>2</sup> )	<i>roadden3kr*</i>	"
<i>Traffic Characteristic Indices (3)</i>		
Total average annual daily traffic (Total AADT)	<i>aadt_total*</i>	2018 Texas: TxDOT 2019; 2017 Other US: USDOT-FHWA 2020; 2018 Mexico: Derived from GOM-SCT 2019
Truck AADT	<i>aadt_truck†</i>	"
Traffic speed	<i>trafficspeed†</i>	"
<b>Human Population Density Indices (4)</b>		
Human population density per km <sup>2</sup>	<i>popden*</i>	CIESIN (2016) (1 km resolution)
Human population density per km <sup>2</sup> in 3 km circular radius (population/28 km <sup>2</sup> )	<i>mnpopden3kr*</i>	Derived from CIESIN (2016)
Human population density per km <sup>2</sup> in 9 km circular radius (population/254.5 km <sup>2</sup> )	<i>mnpopden9kr*</i>	"
Distance to urban areas ≥ 300 humans per km (km)	<i>hiurbdist*</i>	"

**Table A.1 Forty-six environmental predictor indices (30.8 m resolution) evaluated for developing monarch roadkill niche models.**

Variable Index (Number per Category)	Abbreviation <sup>a</sup>	Source
<b>Topographic Indices (22)</b>		
Aspect	<i>aspect</i>	Derived from 1 arc second (30 m resolution) SRTM elevation (NASA JPL 2013)
Compound Topographic Index (CTI) <sup>c</sup>	<i>cti*</i>	"
Curvature (standard combination of profile and planform curvature)	<i>curv</i>	"
Dissection, 90 m circular radius <sup>b</sup>	<i>diss90mr*</i>	"
Elevation (m)	<i>elev</i>	NASA JPL (2013)
Elevation Relief Ratio, 30 m circular radius <sup>b</sup>	<i>err30mr*</i>	Derived from 1 arc second resolution SRTM elevation (NASA JPL 2013)
Latitude (decimal degrees × 10,000)	<i>latitude</i>	
Mean CTI, 500 m circular radius	<i>mncti500mr*</i>	"
Mean CTI, 3 km circular radius	<i>mncti3kr*</i>	"
Mean Flow Accumulation, 500 m circular radius <sup>c</sup>	<i>mnfloacc500mr*</i>	"
Mean Flow Accumulation, 3 km circular radius <sup>c</sup>	<i>mnfloacc3kmr*</i>	"
Mean Sea Cover, 500 m circular radius	<i>mnsea500mr*</i>	"
Mean Sea Cover, 3 km circular radius	<i>mnsea3kr*</i>	"
Mean Slope, 50 m circular radius	<i>mnslope50mr*</i>	"
Mean Slope, 150 m circular radius	<i>mnslope150mr*</i>	"
Sea Distance (m)	<i>seadist*</i>	"
Site Exposure Index (SEI) <sup>b</sup>	<i>sei</i>	"
Slope	<i>slope</i>	"
Slope Cosine Aspect Index (SCAI) <sup>b</sup>	<i>scai*</i>	"
Topographic Position Index (TPI), 30 m circular radius <sup>b</sup>	<i>tpi30mr*</i>	"
TPI, 90 m circular radius <sup>b</sup>	<i>tpi90mr</i>	"
TPI, 300 m circular radius <sup>b</sup>	<i>tpi300mr</i>	"
<b>Land Cover Indices (8)</b> - Percent cover in 500 m radius window × 1000; area/0.78km <sup>2</sup>		

**Table A.1 Forty-six environmental predictor indices (30.8 m resolution) evaluated for developing monarch roadkill niche models.**

Variable Index (Number per Category)	Abbreviation <sup>a</sup>	Source
Artificial surfaces	<i>artsur_500mr*</i>	2010 Globeland30 (Chen et al. 2015, 2017) (30.8 m resolution)
Barren lands	<i>bare_500mr</i>	"
Cultivated land	<i>cult_500m*</i>	"
Forests	<i>forest_500mr</i>	"
Grasslands	<i>grslnd_500mr*</i>	"
Shrublands	<i>shrub_500mr*</i>	"
Water bodies	<i>water_500mr</i>	"
Wetland	<i>wetlnd_500mr</i>	"
<b><i>Climatic Indices</i><sup>d</sup> (4)</b>		
Autumn quarterly mean monthly maximum temperature (°Celsius)	<i>tmax_autq*</i>	for 1960–1990 derived from WorldClim (2017) of Hijmans et al. (2005) (1 km resolution)
Annual mean monthly rainfall (mm)	<i>prec_ann*</i>	"
Autumn quarterly mean monthly actual evapotranspiration/potential evapotranspiration × 1000	<i>etr_t_autq*</i>	"
Autumn mean quarterly wind speed (m/second)	<i>wmsp_autq*</i>	for 1970–2000 derived from WorldClim2 (2017) of Fick and Hijmans (2017) (1 km resolution)

<sup>a</sup>Asterisks indicate variables found valuable in previous MaxEnt monarch roadkill niche models from Kantola et al. (2019) and Tracy and Coulson (2019). Daggers indicate variables not previously used in monarch roadkill niche models.

<sup>b</sup>Calculated using Geomorphometry and Gradient Metrics Toolbox for ArcGIS (Evans et al. 2014).

<sup>c</sup>Flow accumulation for a grid cell is defined by the number of upslope cells from which water can be accumulated as calculated by ArcGIS Flow accumulation tool.

<sup>d</sup>Autumn quarter includes October, November, and December.

## Coastal Funnel Land cover, Climatic, and Topographic Latitude Indices

Land cover, climate, and latitude indices at 30m resolution for the Central Funnel migratory pathway were already available from the previous monarch roadkill modeling study of Kantola et al. (2019). These categories of layers were not available for Coastal Funnel monarch roadkill models of Tracy and Coulson (2019) and needed development for this study. All environmental layers used in MaxEnt models must be perfectly aligned with the same number of raster rows and columns and be in the same projection. We chose the North America Albers Equal Area Conic (NAAEAC) projection for all rasters since equal area projections are best suited for area sensitive calculations used in developing many layers in this study, including topographic indices, such as slope, and land cover indices of the percent cover of land cover in 500 m radius. Methodologies and examples of the developed layers are provided below.

### *Land Cover Indices*

It took several months for fulfillment of an online request from the *GLC30 Information Service* website (<http://www.globallandcover.com/GLC30Download/index.aspx>) for ftp links to download tiles for Globeland30 land cover covering portions of the Coastal Funnel in Louisiana, Texas, and Mexico. Once the tiles were received, they were transformed to the NAAEAC projection and the no data values ( $x < 10$  or  $x > 100$ ) were set to null to remove their slivers from the tile edges. The projected tiles were then joined together one at a time by adding them to a Raster Catalog, followed by use of the Raster Catalog to Raster Dataset tool in ArcGIS. The joined tiles were clipped to the Coastal Funnel study area including a 10 km buffer to allow accurate calculation of neighborhood statistics along the edge of the study area (Fig. A.2). From this clipped and joined land cover raster, a separate raster was then derived for each of the eight selected land cover indices (Table A.1.) with values of "1" for the target land cover and values of "0" for other land covers (Fig. A.3A). The Neighborhood Tool was then used to calculate the Focal Statistics mean value in a 500 m radius to generate layers of percent land cover (e.g., Fig A.3B). A 500 m distance is a liberal approximation of the 400 m perceptual range of adult monarch butterflies (Grant et al. 2018). The percent cover rasters were then aligned and masked (clipped) to 30m resolution Coastal Funnel roadway surfaces for use in the MaxEnt models by simply adding the percent cover raster to a road surface raster, which was also designated as the snap raster in the ArcGIS Environment settings (Fig. A.3C-D).

### *Climatic and Topographic Latitude Indices*

The global 1 km WorldClim and WorldClim2 climate layers and a North America latitude layer in NAAEAC projection used in Kantola et al. (2019) were first clipped to the Coastal



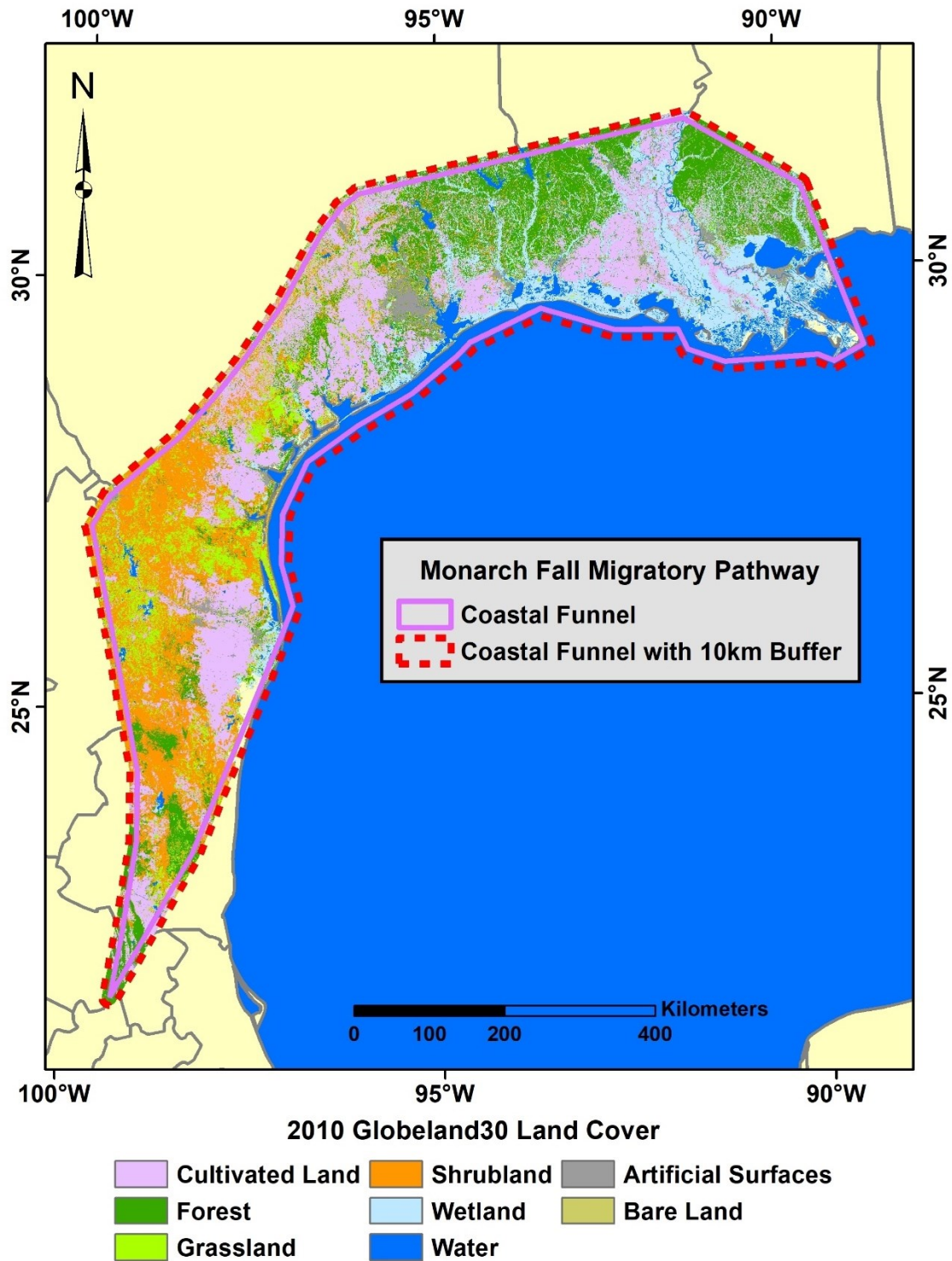
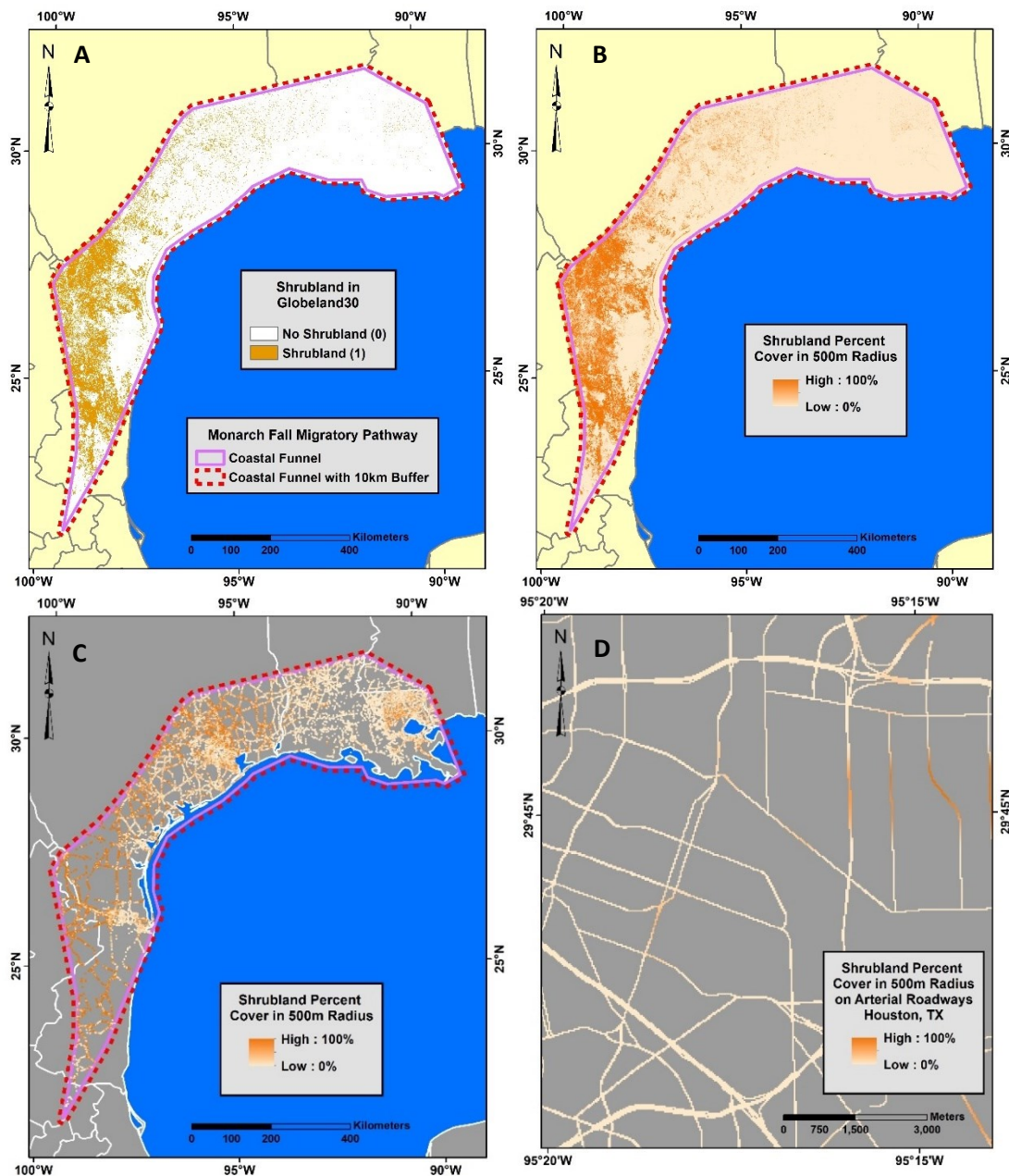


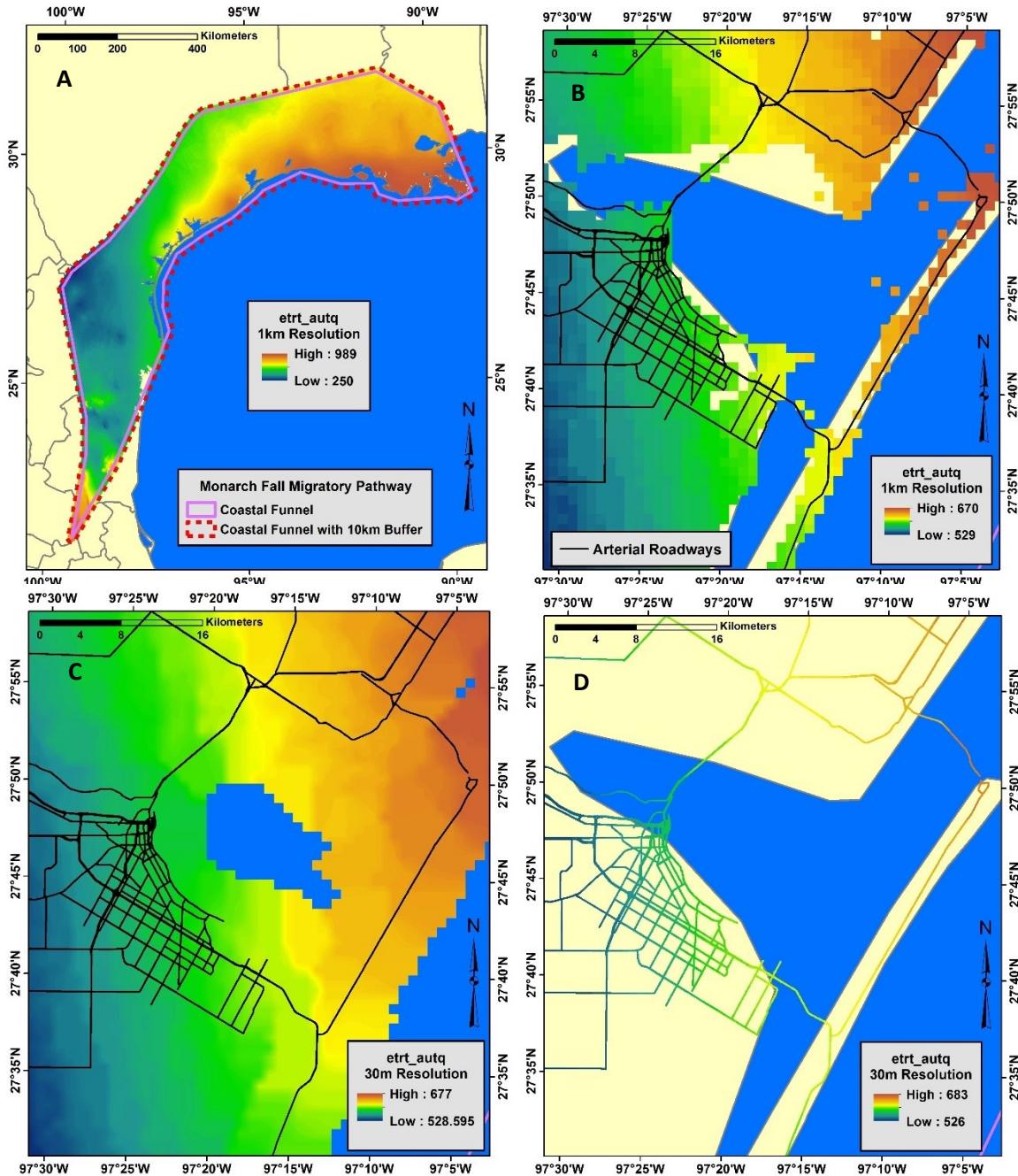
Figure A.2. Globeland30 2010 land cover layer for the Coastal Funnel monarch migratory pathway.



**Figure A.3. Shrubland layer derivation from Globeland30 2010 land cover layer (Fig. A.2) for the Coastal Funnel monarch migratory pathway: (A) shrubland layer, (B) percent shrubland in 500m radius, and percent shrubland masked to roadways for the entire region (C) and in Houston, Texas (D).**

Funnel study area (Fig. A.4A). These layers were found to be missing coverage over causeways where monarch butterfly roadkill was found in the fall of 2018 by Tracy and Coulson (2019) (Fig. A.4.B.). The individual climate/latitude rasters were gradually extrapolated to fill in empty areas over water using the Focal Statistics tool to generate the mean values within a 1km radius for null areas through a process of five iterations. The extrapolation was followed by resampling using bilinear interpolation to convert

climate/latitude layers from 1km to the 30m resolution Globeland30 layer (Fig. A.4C.). The climate and latitude layers were then added to the road surface raster to align the layer and mask it to include only the road surfaces (Fig. A.4D).



**Figure A.4. Actual evapotranspiration/potential evapotranspiration for the autumn quarter (`etrt_autq`) layer derivation for the Coastal Funnel monarch migratory pathway: `etrt_autq` layer at 1km resolution for the Coastal Funnel (A) and Corpus Christi Bay, TX (B); (C) `etrt_autq` layer extrapolated over causeways and resampled to 30 m resolution (D) `etrt_autq` layer masked to roadways.**



## United States Traffic Characteristic Indices

Total traffic volume (total AADT) and traffic classification (truck AADT) layers for the Central and Coastal funnel monarch fall migratory pathways in the United States were obtained online in the form of ArcGIS polyline shapefiles for 2018 in Texas from TxDOT (2019) and for 2017 in the states of Oklahoma, Louisiana, and Mississippi from USDOT-FHWA (2020). Traffic speed limit polyline shapefiles for all these states was obtained for 2017 from USDOT-FHWA (2020) in combination with 2017 AADT data.

### *Traffic Volume and Traffic Classification*

The polyline shapefile AADT data from 2018 for Texas and 2017 for Oklahoma, Louisiana, and Mississippi were merged. The merged AADT shapefile was then transferred to the Open Street Map arterials layer which served as a base road layer in this study, using the ArcGIS Spatial Join tool and specifying either total AADT or truck AADT (representing the traffic classification layer) for the join (Fig. A.5A-B). These arterial AADT layers were then clipped to the Central and Coastal funnels and converted to 30 m resolution rasters before adding them to the base 30 m arterial road raster layers for alignment with other environmental layers.

### *Traffic Speed*

The 2017 traffic speed limit data for Texas, Oklahoma, Louisiana, and Mississippi were merged together, and the same procedure as above was followed to produce 30m resolution traffic speed limit rasters for the Central and Coastal funnels. Missing speed limit values for many road segments in the USDOT-FHWA (2020) layers resulted in many artefactual zero speed limits across arterials. These zero values were uniformly reassigned a value of 30 miles per hour as an approximation, resulting in erroneously large segments of arterials assigned 30 mph speed limits (Fig. A.6.). A more refined method to extend more accurate speed limits along arterial road networks to fill in missing data needs to be developed, like what is being done for the Mexico traffic characteristic indices described in the next final chapter.



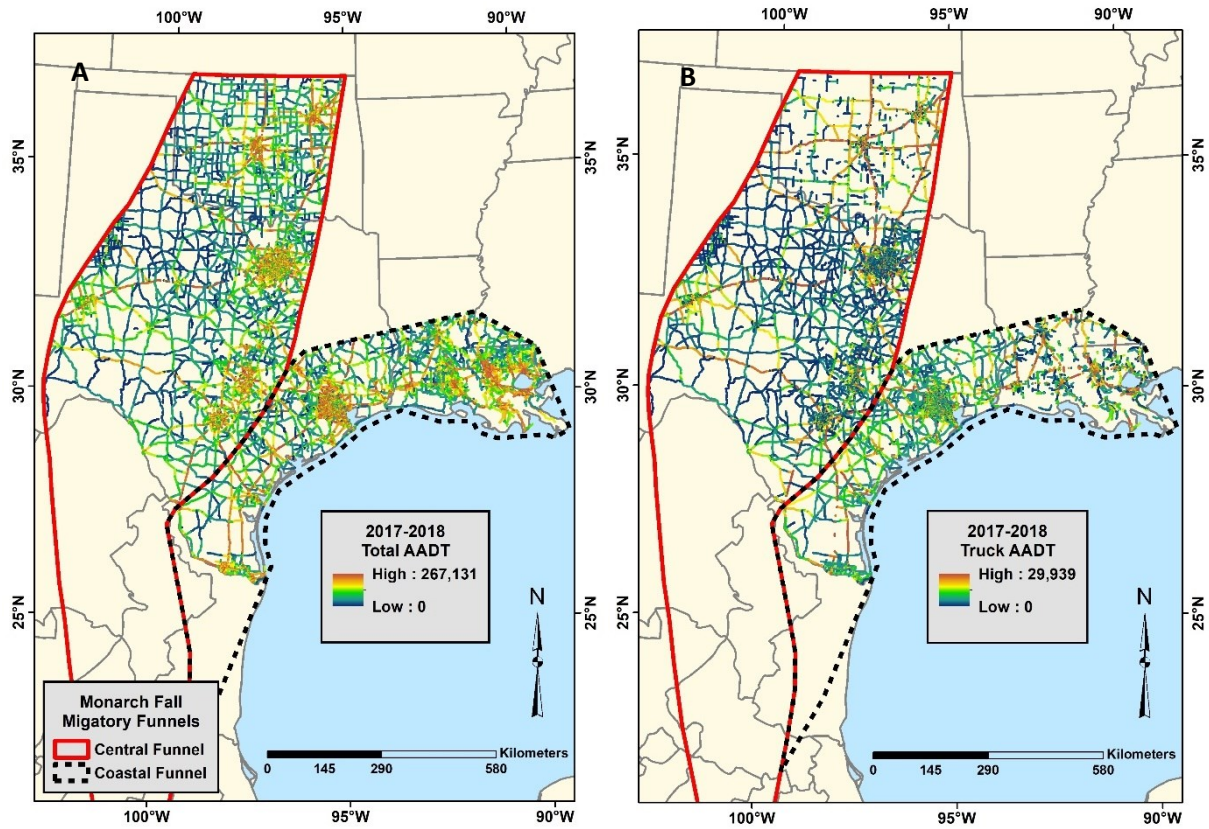
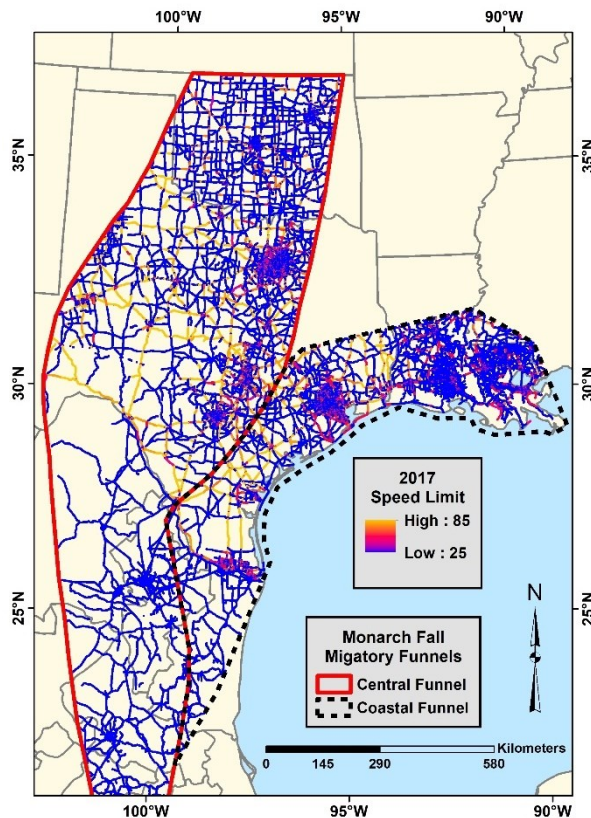


Figure A.5. Average annual daily traffic (AADT) for all vehicles (A) and trucks (B) for arterial roadways in the Central and Coastal monarch fall migratory funnels.

Figure A.6. Speed limit for arterial roadways in the Central and Coastal monarch fall migratory funnels.



## Mexico Traffic Characteristic Indices

This section describes the development of a spatial dataset of traffic characteristics for Mexico's road network. The dataset provides a comprehensive view of traffic (volume and the proportion of different vehicle types) and traffic speed for the portion of the Mexico road network that intersects with the monarch migratory paths. In turn this traffic data will be used to develop the statistical models of monarch mortality that are the focus of this research project.

### *Developing the Mexico Traffic Characteristic Indices*

The Secretariat of Communications and Transportation (SCT) is the federal agency responsible for administering the Mexican road network and the Mexican Institute of Transportation (IMT) is the government agency which carries out traffic operations research. Currently, the SCT and IMT do not provide a spatially interpolated dataset of traffic volumes across the country. The research team were also unable to find a current fully interpolated traffic activity dataset from third party sources.

However, the SCT does publish traffic activity data collected by automatic traffic recorders at discrete locations across Mexico. These data provide Annual Average Daily Traffic (AADT), vehicle classification counts (percentage of different vehicle types such as cars buses and motorcycles that make up the total traffic for a single section of road). The data is provided by the SCT in a Portable Document Format (PDF) file format (Government of Mexico Secretariat of Communications and Transportation 2019) (Table A.2).

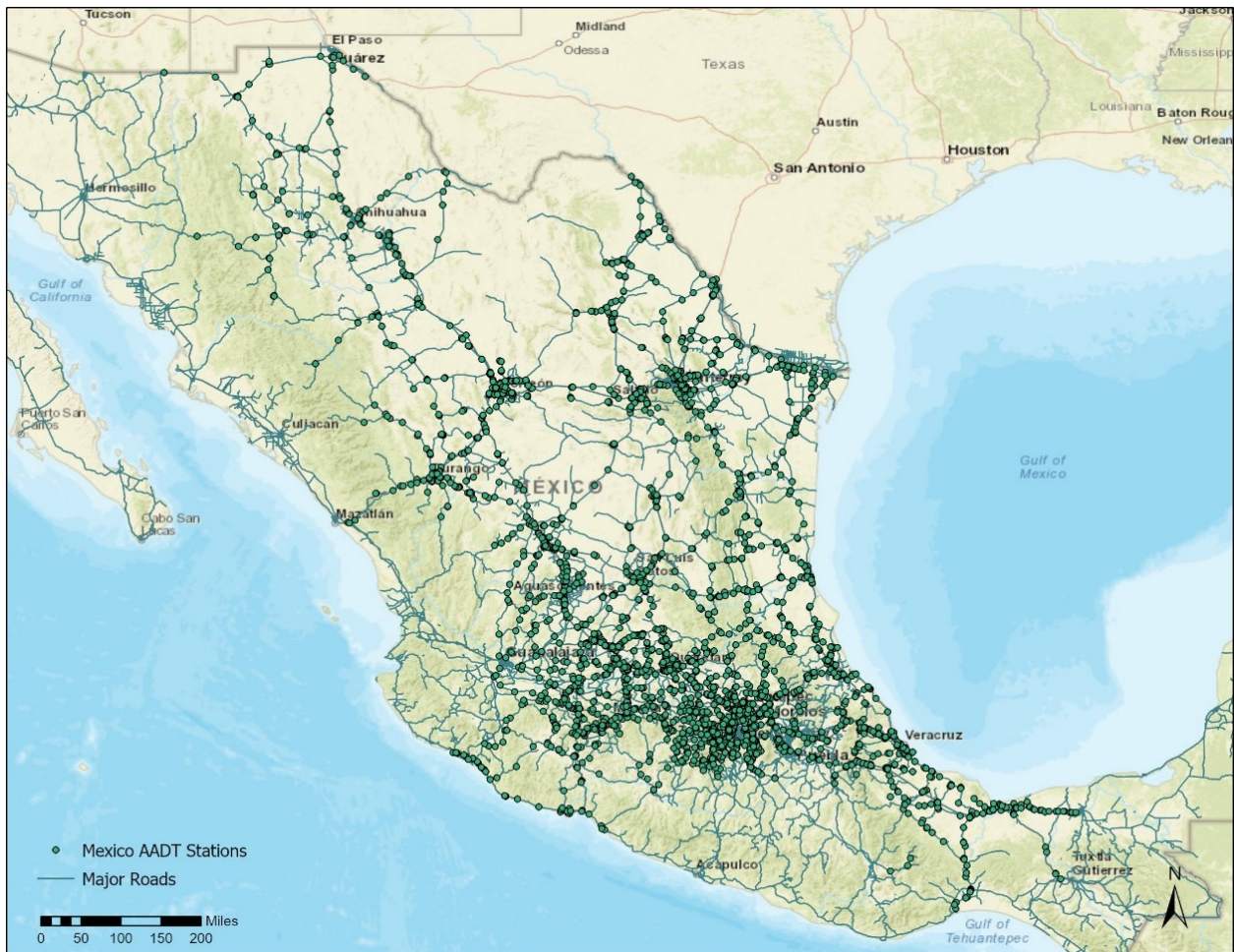
Additionally, various GIS datasets exist that describe the physical features of the road network (e.g., number of lanes, functional class, and road name) (Geofabrik 2017, National Institute of Statistics, Geography and Informatics [INEGI] 2018). The 2018 INEGI Red Nacional de Caminos was used as the primary source of road network in this project, and this road network already has a field for speed limit (velocidad as string).

The researchers used the following steps to develop spatially interpolated Mexico traffic activity dataset:

- 1) The research team converted text-based tables containing traffic count information from the pdf reports to a spreadsheet file (i.e., converting unstructured text to structured quantitative data). Duplicate traffic count data, and other quality assurance issues were addressed.
- 2) The spreadsheet data were then imported to a GIS format using the coordinates (longitude, latitude) of the traffic count station coordinates as a spatial reference (Fig. A.7).

**Table A.2. List of fields available for each Mexican automatic traffic recording station.**

Field	Description
Location	Name of the traffic count station
Latitude	Coordinate of the station
Longitude	Coordinate of the station
AADT	Annual Average Daily Traffic (number of vehicles)
Motorcycles	Percentage of Motorcycles
Cars	Percentage of Cars
Buses	Percentage of Buses
Truck 2 axles	Percentage of Trucks with two axles
Truck 3 axles	Percentage of Trucks with three axles



**Figure A.7. Mexican automatic traffic recording stations along the monarch migratory corridor.**



- 3) The GIS based traffic count stations (represented by a single point) were then spatially joined to the nearest link in the road network. The spatial join was necessary because neither the traffic count data nor the road data contain a consistent reference that links a traffic count station to a specific road link. Traffic count information was assigned to the nearest road segment within 25 meters of each station. All but three station were successfully joined to a road segment.
- 4) Individual road segments (links) were then aggregated using the road name, functional class, number of lanes and speed limit. The aggregation step was used to assign traffic count information (assigned to individual links through the spatial join operation), to neighboring links.
- 5) Minor roads that were not associated with AADT data were removed from the network to reduce the size and complexity of the network.
- 6) Major roads that were not associated with AADT were assigned an average AADT value using nationwide averages (of AADT and classifications) for roads of the same functional class and number of lanes (national averages, Table A.3).

**Table A.3. Mexico average annual daily traffic (AADT) per lane for roads of different functional classes.**

Roadway Functional Class	AADT per Number of Lanes								Mean
	1	2	3	4	5	6	7	8	
Avenue	5846.0	4833.3	11521.8	5928.4		9575.2			6331.9
Boulevard		6244.3	7497.1	9362.1	3915.4	1879.0			7000.6
Street	1887.5	4697.1	10114.1	3569.1	5109.6				5002.4
Road		7324.0	7020.9						7229.3
Highway	3372.3	3752.8	7513.9	3728.7	3899.2	1472.0	1948.6	3226.6	4023.2
Interchange	5058.7	746.5							3980.6
Peripheral									
Ring		7008.8	6412.5	5709.5	8119.0				6689.5
Extension		3737.8	22367.7						4833.6
Highway viaduct				7546.4					7546.4

### Description of Final Layer

The process described above produced a GIS layer detailing estimated traffic activity (AADT and vehicle classifications) for every major road in the Mexico portion of the monarch migratory pathway (Fig. A.8). The final layer consists of five fields describing the road feature: road type, highway name, highway-code, number of lanes and speed limit. Each road segment in the network also includes AADT and vehicle classifications.



An additional flag field is provided that indicates whether the traffic activity information for that link was derived directly by a spatial join, derived by assigning information from a joined link to adjacent links, or is based on national averages (*i.e.*, A.3.).



**Figure A.8. Spatially continuous GIS layer of traffic activity for major roads in the Mexican portion of the monarch migratory corridor.**

## Future Work

The layer developed using the methods described above is the first attempt at providing a spatially continuous source of traffic data to be used to develop models of monarch road mortality. In turn, this layer will be joined to similar GIS layers detailing continuous traffic activity data for US portions of the migratory corridor. An important goal is to make a single, continuous layer of traffic activity for the monarch migratory corridor, and for this layer to be consistent in terms of the traffic data it provides (e.g., traffic volumes, classification counts).

Future work will therefore involve reviewing the Mexico traffic data relative to other areas with a view to selecting the final data fields required for the modeling. The research team will also review the traffic collection methods used in each US state and Mexico, to ensure the meaning of the data are consistent. For example, ensuring a consistency among road functional classes, and traffic classifications. While the methods used to develop the traffic activity layer produce valid estimates of traffic activity throughout the region, the research team will also work on improvements. For example, the research team is exploring an improved method for assigning traffic activity to routes that are not associated with a traffic count. Instead of assigning traffic based on a nationwide (Mexico) average, it is possible to assign or model this information based on local averages. The research team is also working on improved methods to interpolate traffic estimates between two known locations (traffic count stations). These methodologies will also need to be applied for assigning speed limit values from the INEGI Red Nacional de Caminos to the OSM derived arterials base road layer for this study. For each of these methodological improvements, more work is required to explore whether they will result in a more representative data set, and to assess the consistency of a final method in the context of data provided by other jurisdictions (US states).

## References

- Ascensão, F., Desbiez, A.L., Medici, E.P. and Bager, A. 2017. Spatial patterns of road mortality of medium–large mammals in Mato Grosso do Sul, Brazil. *Wildlife Research*, 44:135-146.
- Ascensão, F., Yogui, D., Alves, M., Medici, E.P. and Desbiez, A. 2019. Predicting spatiotemporal patterns of road mortality for medium-large mammals. *Journal of Environmental Management*, 248:109320.
- Barrientos, R. and Bolonio, L. 2009. The presence of rabbits adjacent to roads increases polecat road mortality. *Biodiversity and Conservation*, 18:405-418.
- Barrientos, R. and de Dios Miranda, J. 2012. Can we explain regional abundance and road-kill patterns with variables derived from local-scale road-kill models? Evaluating transferability with the European polecat. *Diversity and Distributions*, 18:635-647.
- Barthelmess, E.L. 2014. Spatial distribution of road-kills and factors influencing road mortality for mammals in Northern New York State. *Biodiversity Conservation*, 23:2491–2514.
- Bellamy C., Scott, C., and Altringham, J. 2013. Multiscale, presence-only habitat suitability models: fine-resolution maps for eight bat species. *Journal of Applied Ecology*, 50:892-901.
- Bencin, H.L., Prange, S., Rose, C. and Popescu, V.D. 2019. Roadkill and space use data predict vehicle-strike hotspots and mortality rates in a recovering bobcat (*Lynx rufus*) population. *Scientific Reports*, 9:1-13.
- Carr, L.W. and Fahrig, L. 2001. Effect of road traffic on two amphibian species of differing vagility. *Conservation Biology*, 15:1071-1078.
- Center for International Earth Science Information Network (CIESIN) - Columbia University. 2016. *Gridded Population of the World, Version 4 (GPWv4): Population Density*. NASA Socioeconomic Data and Applications Center (SEDAC), Palisades, New York. <http://sedac.ciesin.columbia.edu/data/set/gpw-v4-population-density/data-download>
- Chen, J., Chen, J., Liao, A., Cao, X., Chen, L., Chen, X., He, C., Han, G., Peng, S., Lu, M., Zhang, W. 2015. Global land cover mapping at 30 m resolution: A POK-based operational approach. *ISPRS Journal of Photogrammetry and Remote Sensing*, 103:7-27.
- Chen, J., Cao, X., Peng, S. and Ren, H. 2017. Analysis and applications of GlobeLand30: a review. *ISPRS International Journal of Geo-Information*, 6:230.

- Clevenger, A.P. Chruszcz, B. Gunson, K.E. 2003. Spatial patterns and factors influencing small vertebrate fauna road-kill aggregations. *Biological Conservation*, 109:15–26.
- Evans J.S., Oakleaf, J., Cushman, S.A., and Theobald, D. 2014. *An ArcGIS Toolbox for Surface Gradient and Geomorphometric Modeling, version 2.0-0*.  
<https://www.arcgis.com/home/item.html?id=63ffcecf3b2a45bf99a84cdaedefacfc>
- Fabrizio, M., Di Febbraro, M., D’Amico, M., Frate, L., Roscioni, F. and Loy, A. 2019a. Habitat suitability vs landscape connectivity determining roadkill risk at a regional scale: a case study on European badger (*Meles meles*). *European Journal of Wildlife Research*, 65:7.
- Fabrizio, M., Di Febbraro, M. and Loy, A. 2019b. Where will it cross next? Optimal management of road collision risk for otters in Italy. *Journal of Environmental Management*, 251:109609.
- Garrote, G., Fernández-López, J., López, G., Ruiz, G. and Simón, M.A. 2018. Prediction of Iberian lynx road-mortality in southern Spain: a new approach using the MaxEnt algorithm. *Animal Biodiversity and Conservation*, 41:217-225.
- Geofabrik. 2017. OpenStreetMap Data Extracts. <http://download.geofabrik.de/>
- Gomes, L., Grilo, C., Silva, C., and Mira, A. 2009. Identification methods and deterministic factors of owl roadkill hotspot locations in Mediterranean landscapes. *Ecological Restoration*, 24:355-370.
- Google Earth. 2019. Aerial imagery map. Version 7.3.2.5776. <http://google.com/earth/>
- Google Maps. 2019. *Street and Satellite Views*. Google Inc., Mountain View, California. Accessed at: <https://www.google.com/maps?hl=en&tab=rl>
- Government of Mexico Secretariat of Communications and Transportation (GOM-SCT). 2019. Datos viales [Road data]. <http://www.sct.gob.mx/carreteras/direccion-general-de-servicios-tecnicos/datos-viales/2019/>
- Grant, T.J., Parry, H.R., Zalucki, M.P. and Bradbury, S.P. 2018. Predicting monarch butterfly (*Danaus plexippus*) movement and egg-laying with a spatially-explicit agent-based model: The role of monarch perceptual range and spatial memory. *Ecological Modelling*, 374: 37-50.
- Grilo, C., Bissonette, J.A. and Santos-Reis, M. 2009. Spatial-temporal patterns in Mediterranean carnivore road casualties: consequences for mitigation. *Biological Conservation*, 142:301-313.



- Gunson, K.E., Mountrakis, G. and Quackenbush, L.J. 2011. Spatial wildlife-vehicle collision models: a review of current work and its application to transportation mitigation projects. *Journal of Environmental Management*, 92:1074-1082.
- Ha, H. and Schilling, F. 2017. Modelling potential wildlife-vehicle collisions (WVC) locations using environmental factors and human population density: A case-study from 3 state highways in Central California. *Ecological Informatics*, 43:212-221.
- Institute of Statistics, Geography and Informatics (INEGI). 2019. Red Nacional de Caminos (RNC) 2018.  
<https://www.inegi.org.mx/app/biblioteca/ficha.html?upc=889463674641>
- Kantola, T., Tracy, J.L., Baum, K.A., Quinn, M.A. and Coulson, R.N. 2019. Spatial risk assessment of eastern monarch butterfly road mortality during autumn migration within the southern corridor. *Biological Conservation*, 231:150-160.
- Kreling, S.E., Gaynor, K.M. and Coon, C.A. 2019. Roadkill distribution at the wildland-urban interface. *The Journal of Wildlife Management*, 83:1427-1436.
- Lee, E., Klöcker, U., Croft, D.B., and Ramp, D. 2004. Kangaroo-vehicle collisions in Australia's sheep rangelands, during and following drought periods. *Australian Mammalogy*, 26:215-226.
- Lin, Y.P., Anthony, J., Lin, W.C., Lien, W.Y., Petway, J.R., and Lin, T.E. 2019. Spatiotemporal identification of roadkill probability and systematic conservation planning. *Landscape Ecology*, 34:717-735.
- Malo, J.E., Suárez, F. and Díez, A. 2004. Can we mitigate animal-vehicle accidents using predictive models? *Journal of Applied Ecology*, 41:701-710.
- Multi-Resolution Land Characteristics Consortium (MLRC). 2019. *Data: Land Cover*.  
<https://www.mrlc.gov/data?f%5B0%5D=category%3Aland%20cover>
- NASA Jet Propulsion Laboratory (JPL) (2013) NASA Shuttle Radar Topography Mission [SRTM] United States 1 arc second. Version 3. 6oS, 69oW. NASA EOSDIS Land Processes DAAC, USGS Earth Resources Observation and Science (EROS) Center, Sioux Falls, South Dakota (<https://lpdaac.usgs.gov>).  
<http://dx.doi.org/10.5067/MEaSURES/SRTM/SRTMUS1.003>
- Roger, E. and Ramp, D. 2009. Incorporating habitat use in models of fauna fatalities on roads. *Diversity and Distributions*, 15:222-231.
- Santori, C., Spencer, R.J., Van Dyke, J.U. and Thompson, M.B. 2018. Road mortality of the eastern long-necked turtle (*Chelodina longicollis*) along the Murray River, Australia: an assessment using citizen science. *Australian Journal of Zoology*, 66:41-49.

- Santos, S.M., Lourenco, R., Mira, A. and Beja, P. 2013. Relative effects of road risk, habitat suitability, and connectivity on wildlife roadkills: the case of tawny owls (*Strix aluco*). *PLoS One*, 8(11): e79967. doi:10.1371/journal.pone.0079967
- Seiler, A. 2005. Predicting locations of moose-vehicle collisions in Sweden. *Journal of Applied Ecology*, 2:371–382.
- Sillero, N., Poboljšaj, K., Lešnik, A. and Šalamun, A. 2019. Influence of landscape factors on amphibian roadkills at the national level. *Diversity*, 11:13.
- Texas Department of Transportation (TxDOT). 2019. *TxDOT Roadway Inventory OnSystem*. 2018 Polyline Shapefile including AADT and Speed Limit. [https://gis-txdot.opendata.arcgis.com/datasets/46c6ad08e47e4117af4b12b9b2aa7e8d\\_0?geometry=-102.661%2C30.214%2C-99.192%2C31.041](https://gis-txdot.opendata.arcgis.com/datasets/46c6ad08e47e4117af4b12b9b2aa7e8d_0?geometry=-102.661%2C30.214%2C-99.192%2C31.041)
- Texas Natural Resources Information System (TNRIS). 2019. *National Agricultural Imagery Program (NAIP) Imagery, Sutton County, Texas, 2014, Digital Orthorectified Images (DOQ)*. [https://s3.amazonaws.com/data.tnris.org/e7d2ccee-5288-4257-85bc-e4a2babf91ee/resources/naip14-1m\\_48435\\_nc.zip](https://s3.amazonaws.com/data.tnris.org/e7d2ccee-5288-4257-85bc-e4a2babf91ee/resources/naip14-1m_48435_nc.zip)
- Tracy, J.L., Trabucco, A., Lawing, A.M., Giermakowski, J.T., Tchakerian, M., Drus, G.M. and Coulson, R.N. 2018. Random subset feature selection for ecological niche models of wildfire activity in Western North America. *Ecological Modelling*, 383:52–68.
- Tracy, J.L., Kantola, T., Baum, K.A. and Coulson, R.N. 2019. Modeling fall migration pathways and spatially identifying potential migratory hazards for the eastern monarch butterfly. *Landscape Ecology*, 34:443–458.
- Tracy J.L., and Coulson R.N. 2019. *Eastern Monarch Butterfly Fall Migratory Roadkill Distribution and Hotspot Regions within the Coastal and Central Migratory Funnels of Texas*. Texas A&M Department of Entomology/Texas Transportation Institute Project Final Report. TxDOT Environmental Affairs Division, Austin, Texas. 32 pp. [https://www.dropbox.com/s/an9wuzkyr54xdb0/TTI\\_TAMU%20Texas%20Monarch%20Roadkill%20Fall%202018%20Report.docx?dl=0](https://www.dropbox.com/s/an9wuzkyr54xdb0/TTI_TAMU%20Texas%20Monarch%20Roadkill%20Fall%202018%20Report.docx?dl=0)
- US Department of Transportation, Federal Highway Administration (USDOT-FHWA). 2013. *Highway Functional Classification Concepts, Criteria and Procedures*. [https://www.fhwa.dot.gov/planning/processes/statewide/related/highway\\_functional\\_classifications/fcauab.pdf](https://www.fhwa.dot.gov/planning/processes/statewide/related/highway_functional_classifications/fcauab.pdf)
- USDOT-FHWA. 2020. *HPMS [Highway Monitoring Performance System] Public Release of Geospatial Data in Shapefile Format*. Polyline shapefiles for US states for 2017 including AADT and Traffic Speed. <https://www.fhwa.dot.gov/policyinformation/hpms/shapefiles.cfm>

- US Geological Survey (USGS), 2019. The National Map Viewer, USGS National Geospatial Technical Operations Center, Denver, Colorado.  
<http://viewer.nationalmap.gov/viewer/>
- Valerio, F., Carvalho, F., Barbosa, A.M., Mira, A. and Santos, S.M. 2019. Accounting for connectivity uncertainties in predicting roadkills: a comparative approach between path selection functions and habitat suitability models. *Environmental Management*, 64:329-343.
- Visintin, C., Van Der Ree, R. and McCarthy, M.A. 2016. A simple framework for a complex problem? Predicting wildlife–vehicle collisions. *Ecology and Evolution*, 6:6409–6421.
- Visintin, C., Van Der Ree, R. and McCarthy, M.A. 2017. Consistent patterns of vehicle collision risk for six mammal species. *Journal of Environmental Management*, 201:397-406.
- WorldClim. 2017. *WorldClim Version 1*. <http://www.worldclim.org/version1>
- WorldClim2. 2017. *WorldClim Version 2*. <https://worldclim.org/version2>
- Wright, P.G., Coomber, F.G., Bellamy, C.C., Perkins, S.E. and Mathews, F. 2020. Predicting hedgehog mortality risks on British roads using habitat suitability modelling. *PeerJ*, 7:e8154.
- Yue, S., Bonebrake, T.C. and Gibson, L. 2019. Informing snake roadkill mitigation strategies in Taiwan using citizen science. *The Journal of Wildlife Management*, 83:80-88.